



Industrial stairs and working platforms

General information/
Operation conditions from page 248

Internal tension system from page 252

Quick change system from page 262

Accessories from page 268

Industrial stairs and working platforms

...no drilling or welding, no mitre cut – just assemble.



Internal tension system

Principle: The clamping rocker is tilted by screwing in the set screw. The other side of the clamping rocker pushes the pressure piece against the inner side of the tube. Without the need for any mechanical machining, the tube construction is positively and quickly connected by simply tightening a screw.

Clamping set including clamping screw, clamping rocker, thrust pad and screw cap

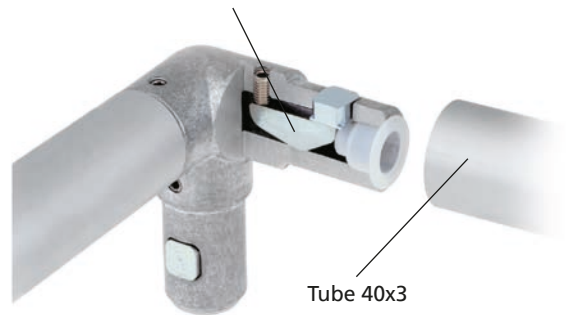

Quick change system

Working and machining areas which in the past required additional guards can now be made accessible with just a few flicks of the wrist and without the need for any tools thanks to the ITAS quick change system. This makes the complicated removal of entire rail segments a thing of the past.



Features:

- Connect tubes without annoying transitions
- No mechanical treatment required – just cut the material to length and assemble
- Flexible – elements can be dismantled at any time
- Simple and stable system
- Plan and assemble – it's as simple as that!

Options:

- Other surface colours are available on request



Table of contents

Properties/performance data	Technical data p. 250
	Loads / System description p. 250
	Building regulations p. 251
Versions (Dimensions, code numbers)	Internal tension system p. 252
	Quick change system..... p. 266
	Fax request form p. 277
Accessories	Aluminium tube p. 269
	Surface element support p. 269
	Stair railing support TGHF p. 270
	Stair cross beam profile p. 271
	Step profile p. 272
	Side plate p. 273
	Stair joint p. 274
	Stair corner joint p. 275
	Tools/spare parts..... p. 275

Technical data

Basic information / mechanical properties

- ITAS die-cast elements clamping mechanism inside from steel (zinc plated)

Loads

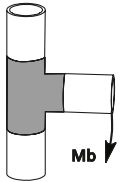

Bending moment Mb [Nm]

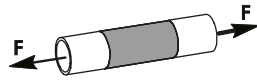

Adh. force: static pull, dynamic pull+pressure

Size Type	Including static safety factor $v = 2,5$		Including dynamic safety factor $v = 1,5$	
	F [N]	Mb [Nm]	F [N]	Mb [Nm]
FI 40	1250	340	1200	160
MI40	1250	340	1200	160
WI40	1250	200	1200	160
WIT40	1250	200	1200	160
WIE40	1250	200	1200	160
WITE40	1250	200	1200	160

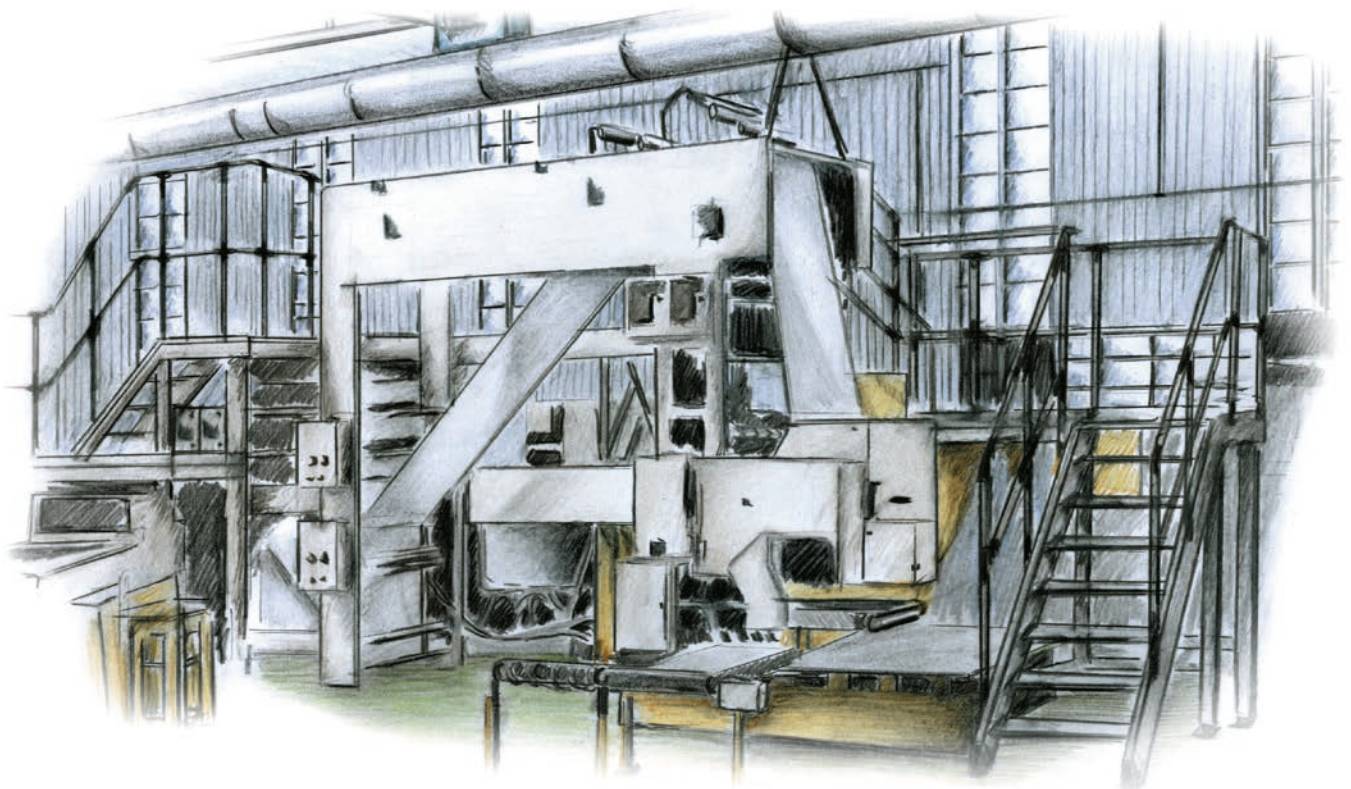

ITAS – Load data

- Load data according to DIN EN 1991-1-1:2010-12
- Maximum permitted load of steps (for a length of 1,2 m) 1500 N
- Maximum permitted load of stairs cross beams (for a 45° angle and a length of 4 m without support) 3500 N
- Maximum permitted load of railing (distance between pillars 0,7 m) 500 Nm
- The maximum permitted load of the platform depends on the base construction. It cannot exceed the maximum permitted load of the base clamps used.
- **Technical safety requirements in accordance with DIN EN ISO 14122 part 1-4**

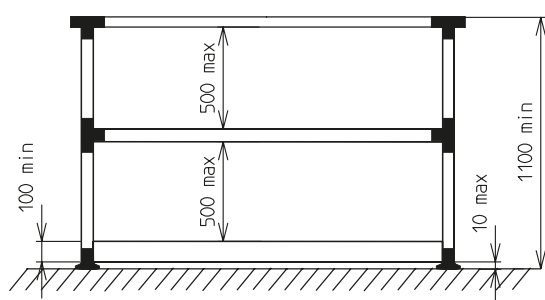

Example for a horizontal railing

- The railing must have at least one knee rail
- Do not exceed a free space between the handrail and knee rail and foot rail of 500 mm
- Fit a foot rail with a minimum height of 100 mm maximum 10 mm above the step level

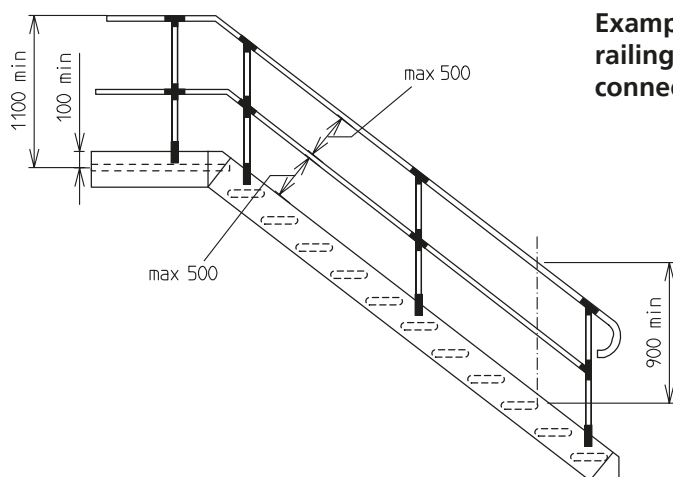

Example for a stair railing - catwalk connector

- A staircase must have at least one handrail
- With a flight width equal to or exceeding 1200 mm two handrails must be provided in the same manner as with all ladder stairs.

Building regulations for railings according to UVV, VBG1 and conforming to DIN EN ISO 14122-3.

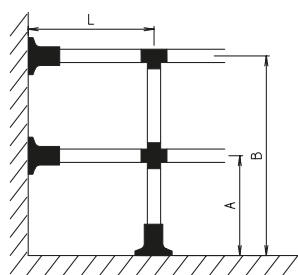

Example 1:
wall and floor fixing

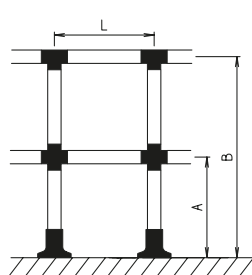

Example 2: self-sup-
porting with floor fixing

Example	Dimension max.		
	A	B	L
1	500	1000	1500*
2	500	1000	1500*

* The support spacing "L" must ensure that 340 Nm for base type FI40 is not exceeded.

Internal tension system

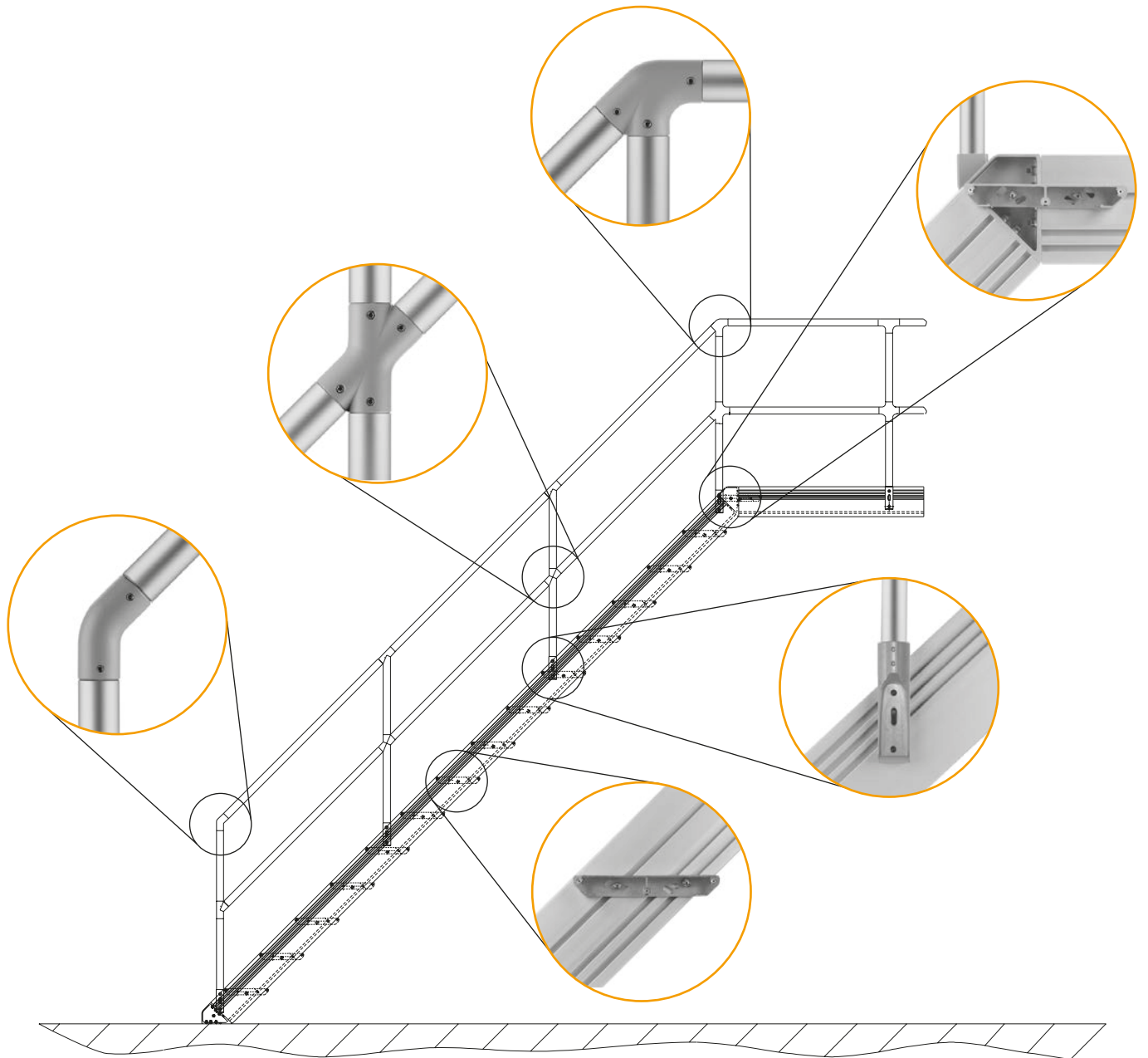

Features:

- Technically optimised solution for the installation of railings, frame structures, boundaries, superstructures, stairs and working platforms of all kinds.
- The smooth transitions between all of the elements used and the connecting tube are kind on the hands
- Positive, quick connection with the simple tightening of a screw – without the need for any mechanical machining



MI 40



KI 40



KI 40H-45°



WIY 40-45°



WI 40



WI 40-45°
30°, 38°, 52°, 60°



WIT 40H-45°R



FIW 40



WIT 40



WIT 40-45°



WIT 40H-45°L



FI 40



WIE 40



WIT 40H-45°



WIV 40H-45°



TSI



WITE 40



KI 40-45°



WIV 40-45°



TSI 40-WI



MIG 40 RR



MIG 40 RZ



MIG 40 ZZ



TGHF

ITAS

Internal tension system

On request:

- ITAS elements in various RAL colours

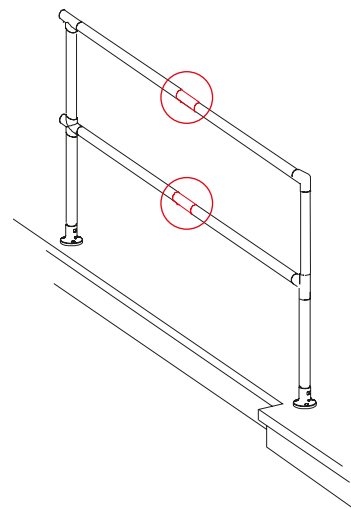
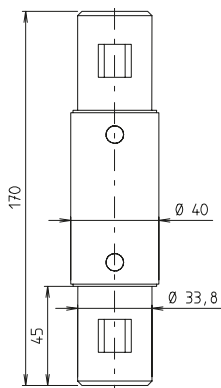

Coupler MI 40

Code No.	Type	m [g]
14403410025	MI 40	453

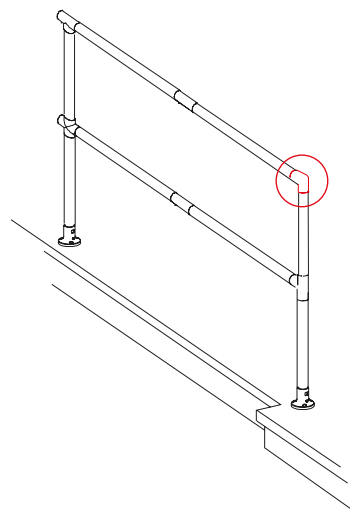
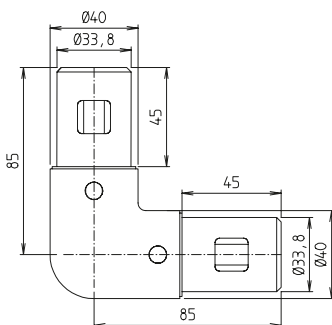

Elbow 90° WI 40

Code No.	Type	m [g]
11403421025	WI 40	455

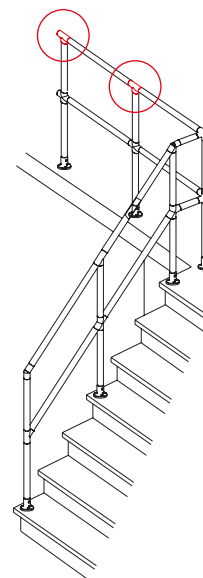
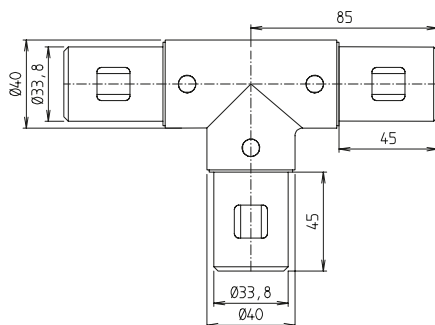

T-joint 90° WIT 40

Code No.	Type	m [g]
11403423025	WIT 40	625

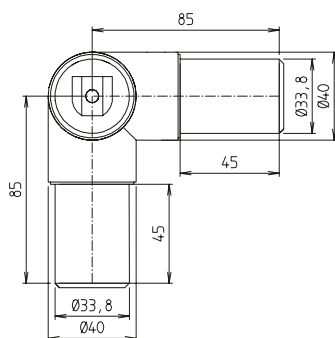

Corner joint WIE 40

Code No.	Type	m [g]
11403422025	WIE 40	624

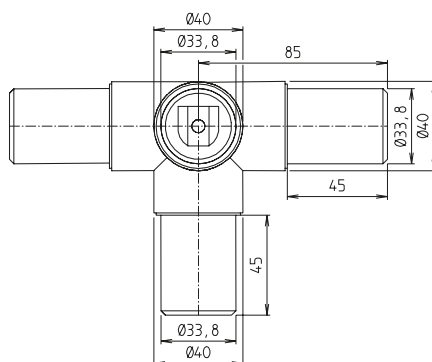
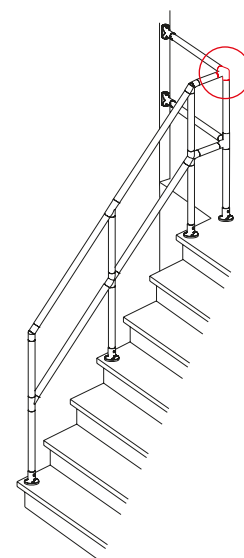

Corner T-joint WITE 40

Code No.	Type	m [g]
11403424025	WITE 40	786

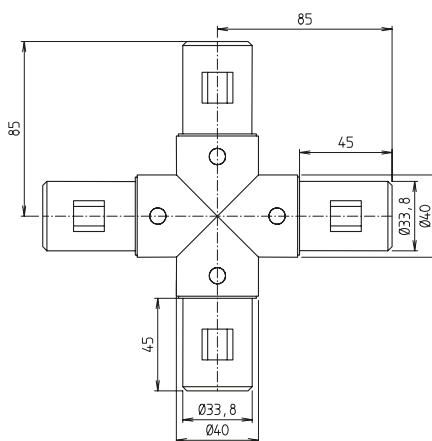
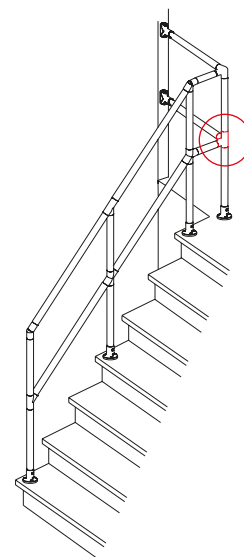

Cross KI 40

Code No.	Type	m [g]
10403410025	KI 40	795

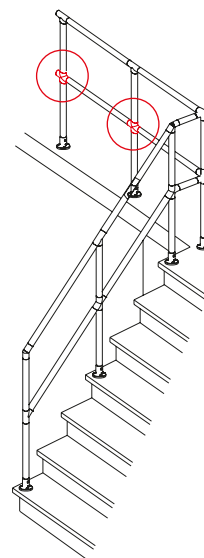

ITAS

Internal tension system

On request:

- ITAS elements in various RAL colours



Elbow WI 40

Code No.	Type	A	B [mm]	m [g]
11404521025	WI 40-45°	135°	95	520
11405021025	WI 40-30°	150°	85	456
11404221025	WI 40-38°	142°	85	456
11402821025	WI 40-52°	128°	85	455
11402021025	WI 40-60°	120°	85	455

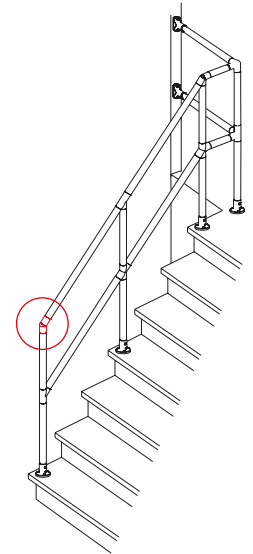
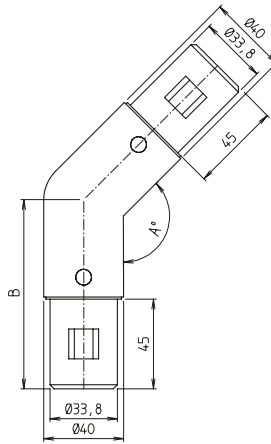

T-joint 45° WIT 40-45°

Code No.	Type	m [g]
11404523025	WIT 40-45°	715

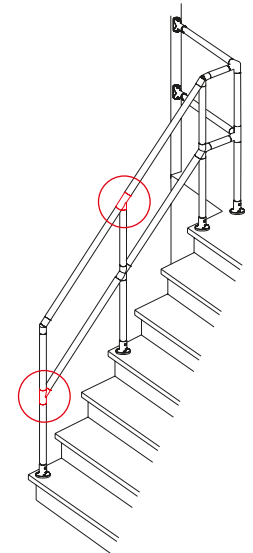
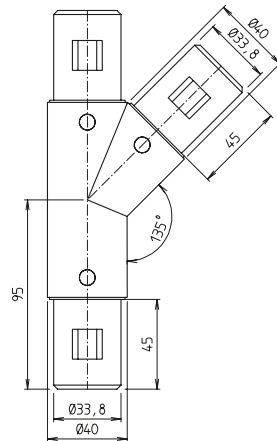

T-joint horizontal 45° WIT 40H-45°

Code No.	Type	m [g]
11404525025	WIT 40 H-45°	715

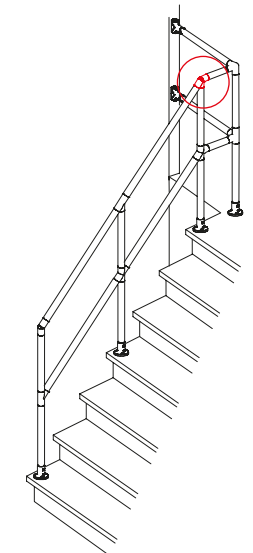
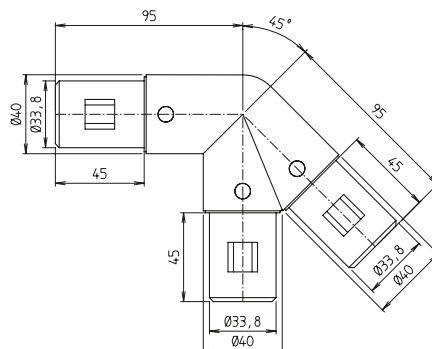

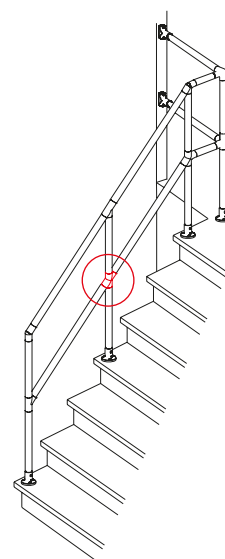
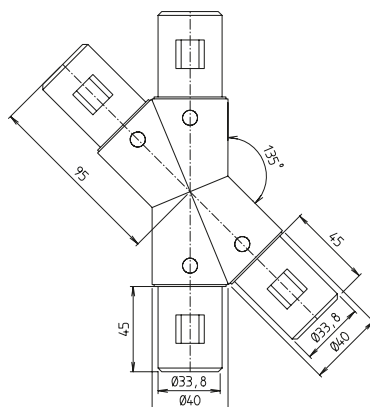

Cross KI 40-45°

Code No.	Type	m [g]
10404510025	KI 40-45°	901

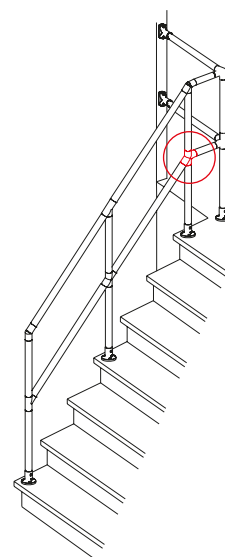
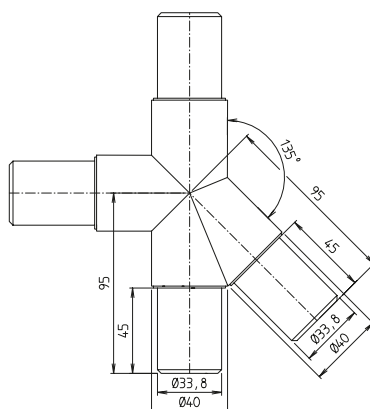

Cross horizontal KI 40H-45°

Code No.	Type	m [g]
10404521025	KI 40 H-45°	940

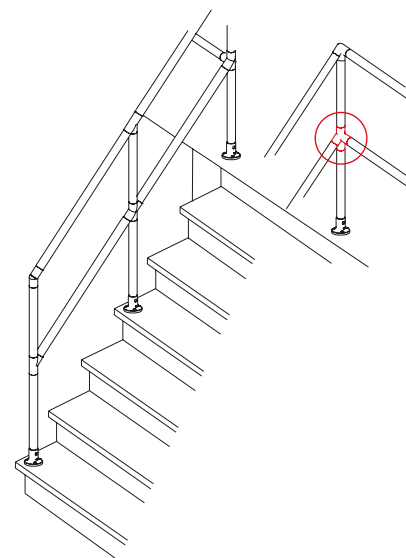
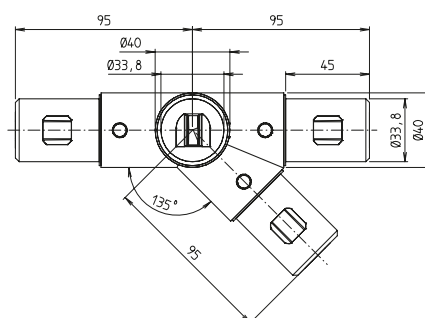

WIT 40H-45°R

Code No.	Type	m [g]
11404528025	WIT 40H-45°R	908

ITAS

Internal tension system

On request:

- ITAS elements in various RAL colours

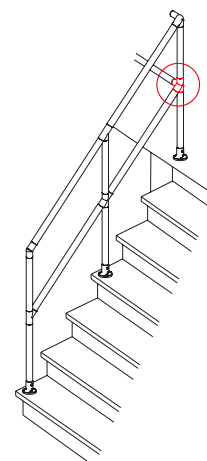
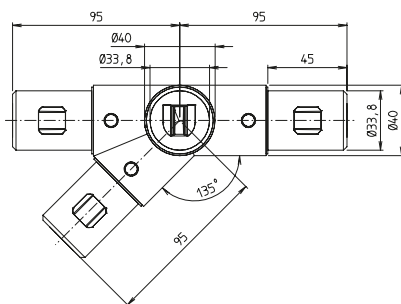

WIT 40H-45°L

Code No.	Type	m [g]
11404529025	WIT 40H-45°L	903

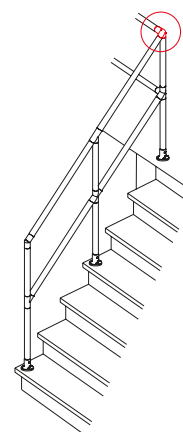
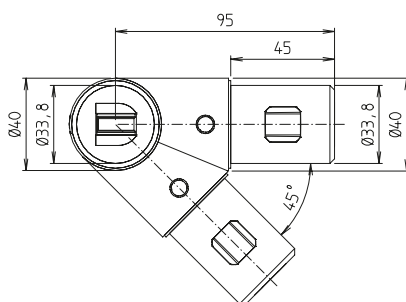

WIV 40H-45°

Code No.	Type	m [g]
11404527025	WIV 40H-45°	693

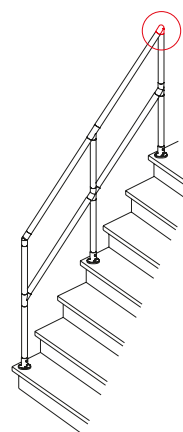
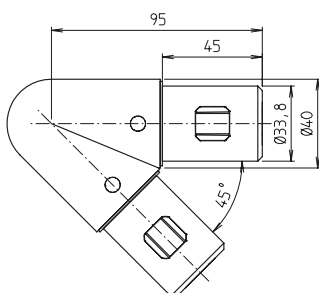

WIV 40-45°

Code No.	Type	m [g]
11404526025	WIV 40-45°	486

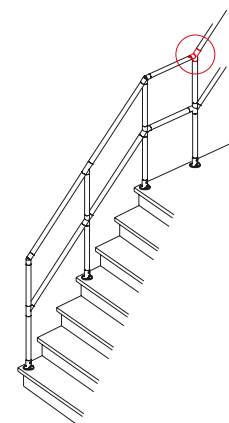
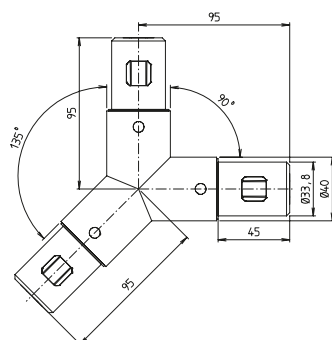

WIY 40-45°

Code No.	Type	m [g]
11404530025	WIY 40-45°	733



MIG 40 RR

Code No.	Type	m [g]
18403456025	MIG 40 RR	261

With tothing – 180° swivelling range, 15° locking increments
 Tothing can be removed for continuously variable adjustment

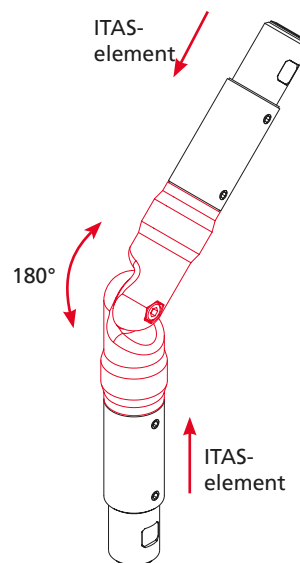
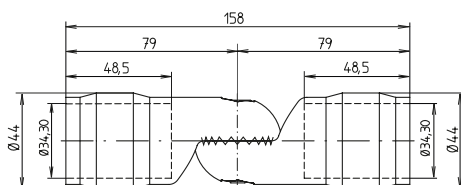

MIG 40 RZ

Code No.	Type	m [g]
18403455025	MIG 40 RZ	374

With tothing – 180° swivelling range, 15° locking increments
 Tothing can be removed for continuously variable adjustment

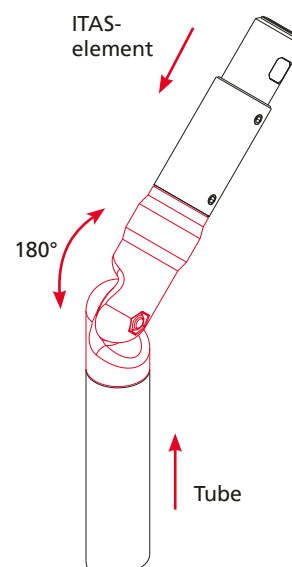
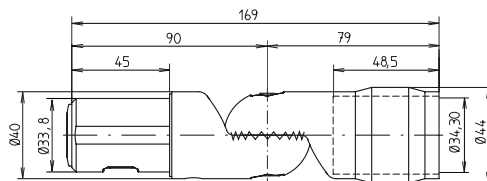

MIG 40 ZZ

Code No.	Type	m [g]
18403457025	MIG 40 ZZ	483

With tothing – 180° swivelling range, 15° locking increments
 Tothing can be removed for continuously variable adjustment

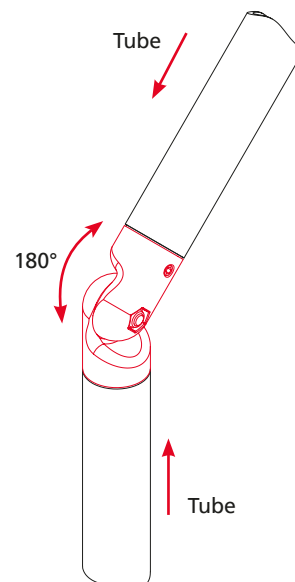
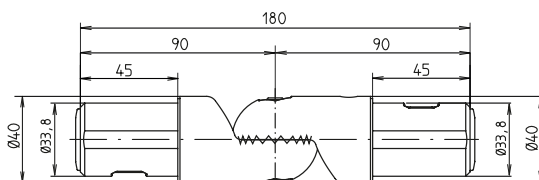

Internal tension system

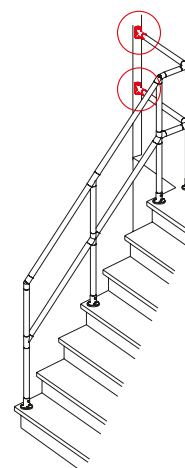
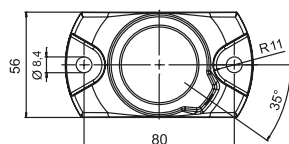
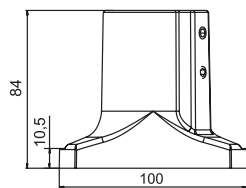

FIW 40 (Wall flange)

Code No.	Type	m [g]
13403430025	FIW 40	428

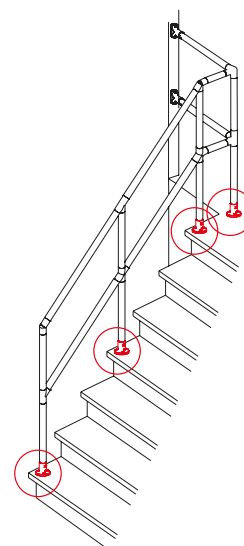
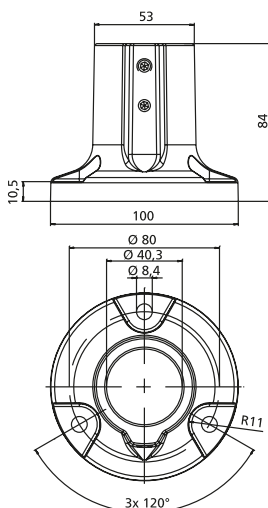

Base FI 40

Code No.	Type	m [g]
13403431025	FI 40	487



Insert depth

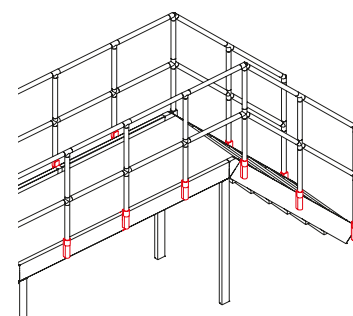
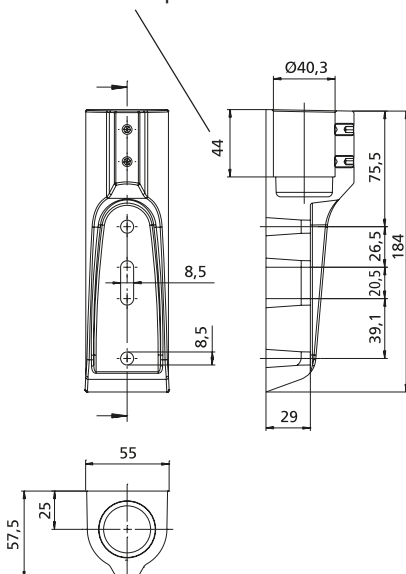

Stair railing support TGHF

Code No.	Type
13403429025	TGHF 40
93800	fitting TGHF cross beam profile

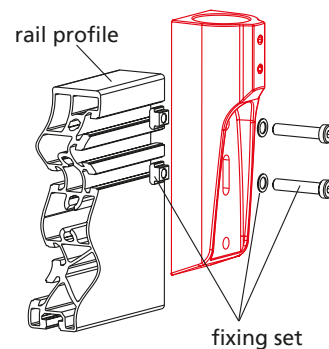

Quick change system

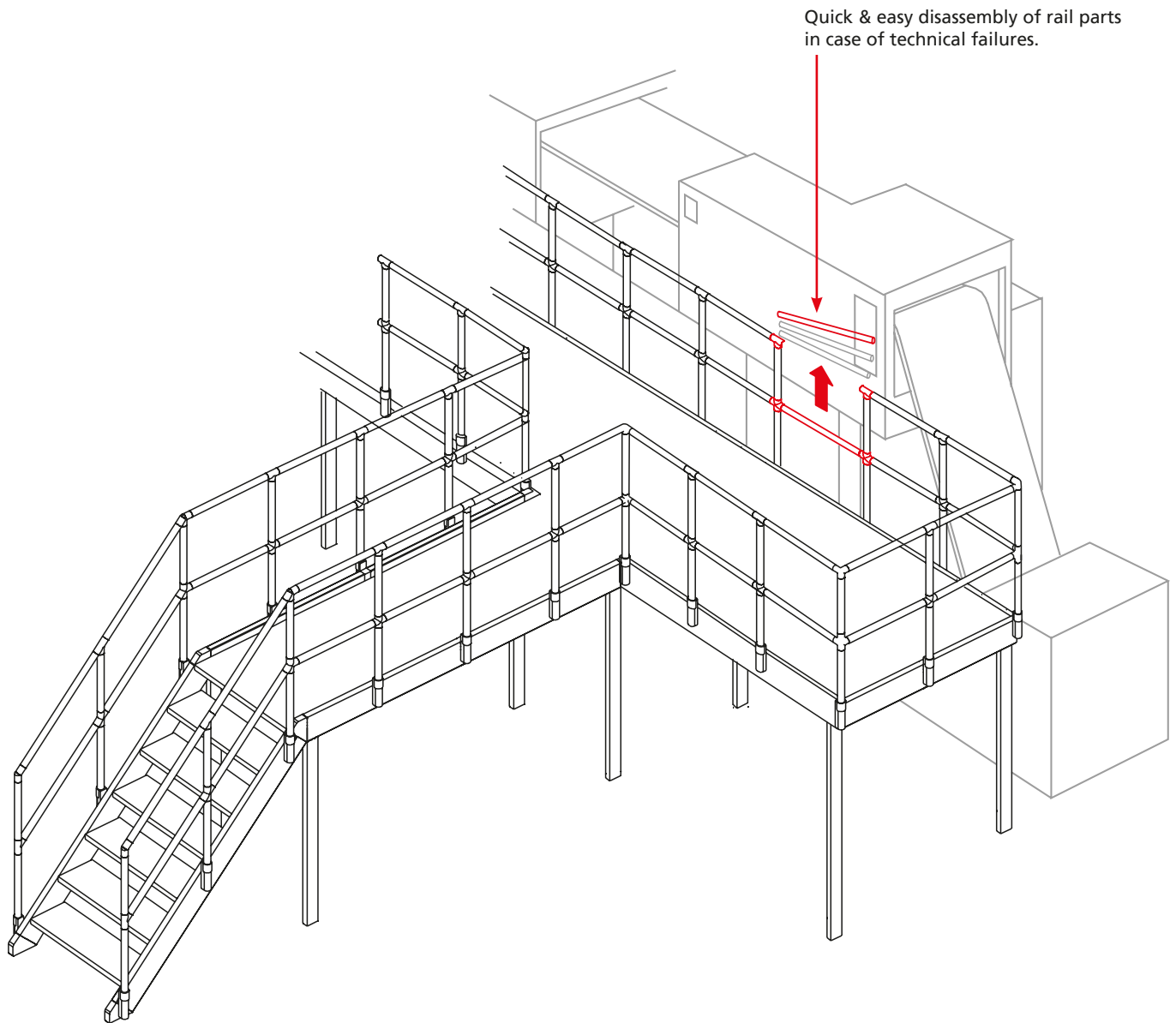

Features:

- This system combines the proven flexibility of the internal tension system and an easy assembly and dismantling system which cannot be compared to that of common railing systems.
- It enables protected working and machine areas to be more accessible.
- The new ITAS Quick change system permits an easy access to specific machine parts in case of technical malfunctioning: all you need is to remove the necessary part of the balustrade.



WI 40-SW1



KI 40H-45°SW1



KI 40-SW2



WIT 40-SW1



WIT 40-SW2



WIT 40H-45°SW1



WIE 40-SW2



WITE 40-SW2

Dismantling of quick change system



Release stopper with a screwdriver



Loosen clamping screw

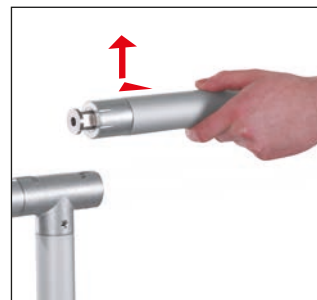

Turn the cross strut to 90° and then raise and release



ITAS

Quick change system

On request:

- ITAS elements in various RAL colours

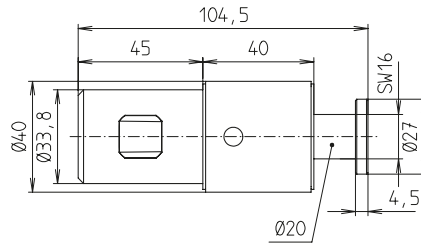

Attention:

The clamping element MI-H 40-SW is included in the delivery set of the following quick change elements. This element does not need to be ordered separately

MI-H 40-SW

Code No.	Type	m [g]
14403411025	MI-H 40-SW	307

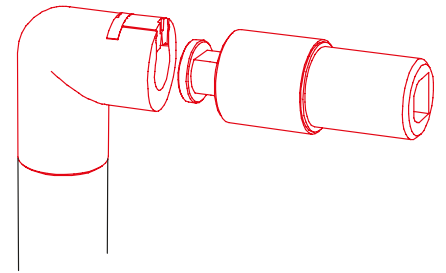
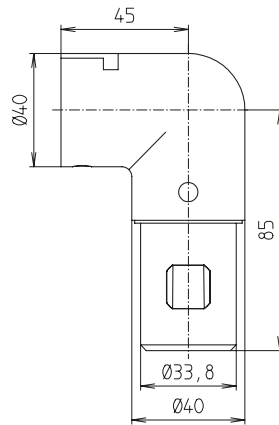

WI 40-SW1

Code No.	Type	m [g]
11403425025	WI 40-SW1	643

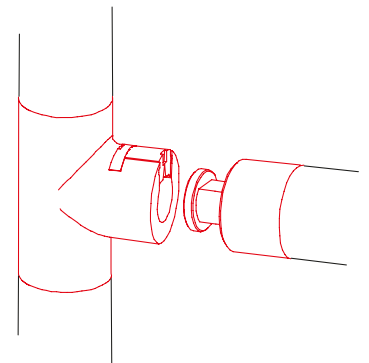
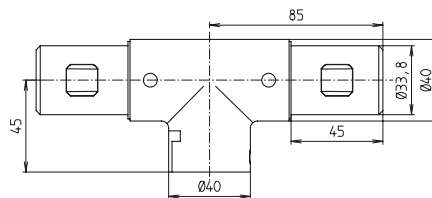

WIT 40-SW1

Code No.	Type	m [g]
11403428025	WIT 40-SW1	828

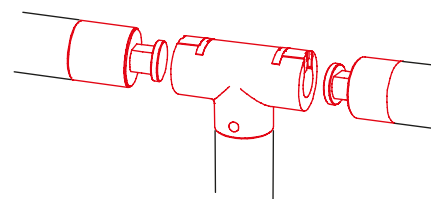
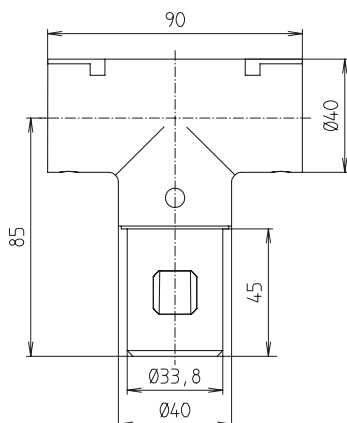

WIT 40-SW2

Code No.	Type	m [g]
11403426025	WIT 40-SW2	1020

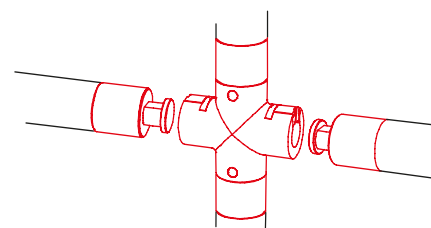
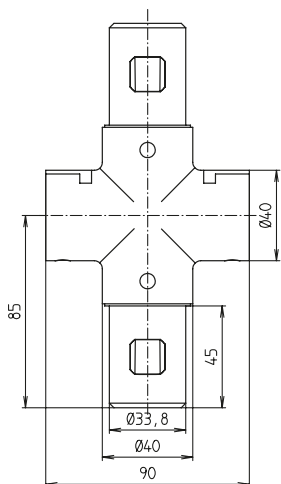

KI 40-SW2

Code No.	Type	m [g]
10403411025	KI 40-SW2	1221

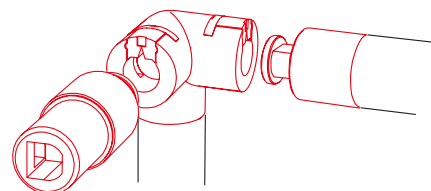
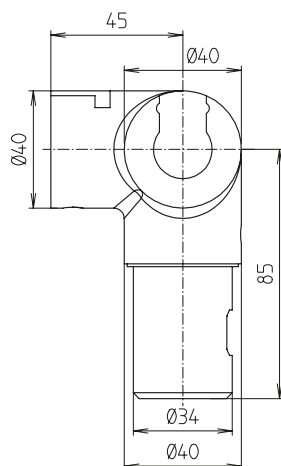

WIE 40-SW2

Code No.	Type	m [g]
11403427025	WIE 40-SW2	1034

ITAS

Quick change system

On request:

- ITAS elements in various RAL colours

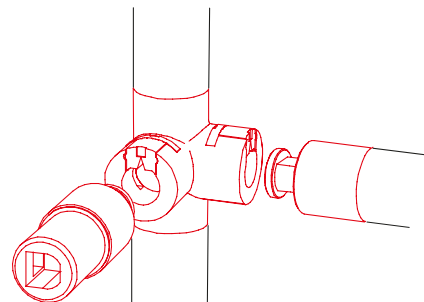
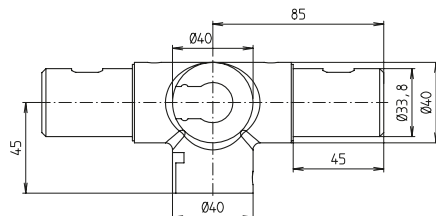

WITE 40-SW2

Code No.	Type	m [g]
11403429025	WITE 40-SW2	1209

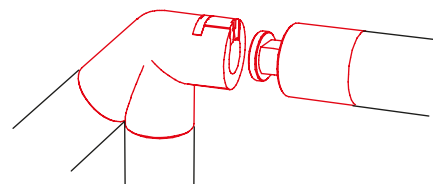
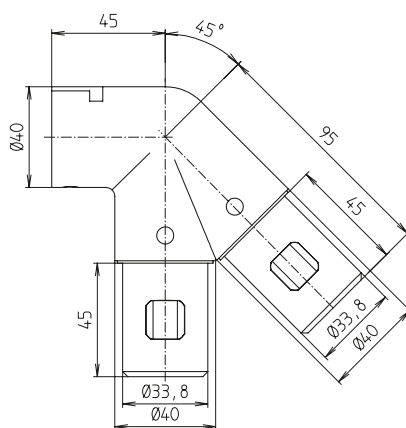

WIT 40H-45°SW1

Code No.	Type	m [g]
11404524025	WIT 40H-45°SW1	902

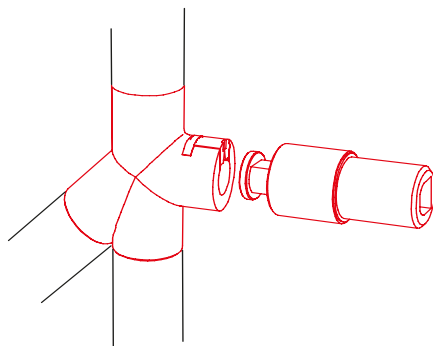
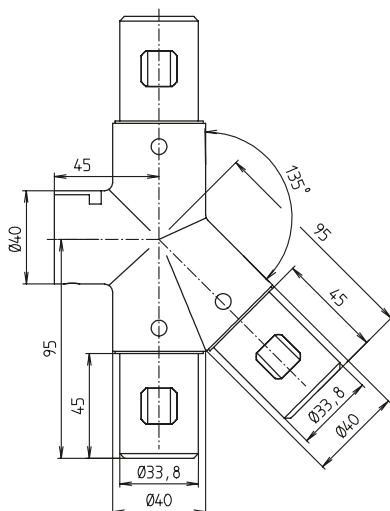

KI 40H-45°SW1

Code No.	Type	m [g]
10404511025	KI 40H-45°SW1	1068



The mobile ITAS ladder makes accessing various storage shelves easier.



Accessories



Aluminium tube
Ø 40x3



Angle plate
TGHF



Side plate



Surface element support
FEH-I 40

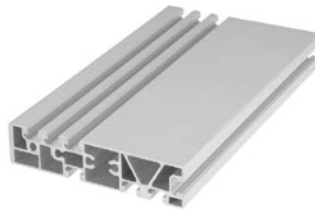

Stair cross beam
profile



Stair joint

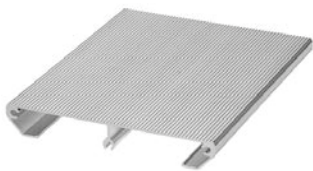

Step profile



Stair corner joint



Material:
 AlMgSi 0,5 F22 / EN AW 6060
 Resistance moment $W = 3 \text{ cm}^3$
 Moment of inertia $I = 6 \text{ cm}^4$

Aluminium tube

Code No.	Type	Version
8240302	40x3	clear anodized
8240303	40x3	black anodized

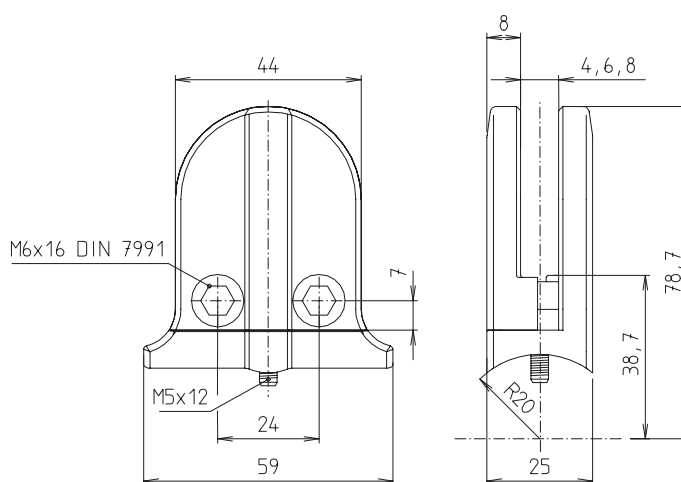
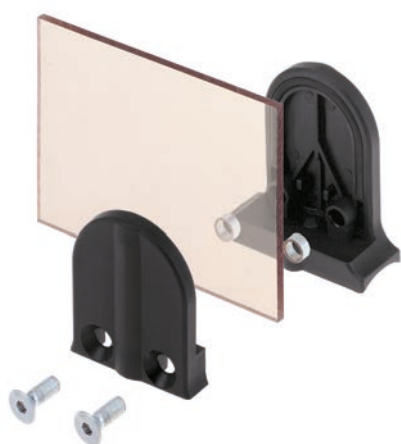
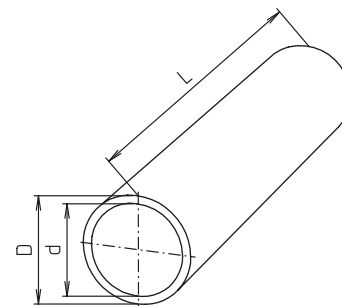
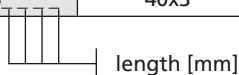

Features:

- The surface element support enables the clamping of panels of 4, 6 or 8 mm thickness.
- The support can be used with a $\text{Ø}40$ tube (min. wall thickness 3 mm)
- Only a 4.5 mm hole has to be bored into the tube where the support is then fixed with a thread former screw.

Material: PA-GF, black
 Fixation set galvanized

FEH-I 40 (Surface element support)

Code No.	Type
91803	FEH-I 40

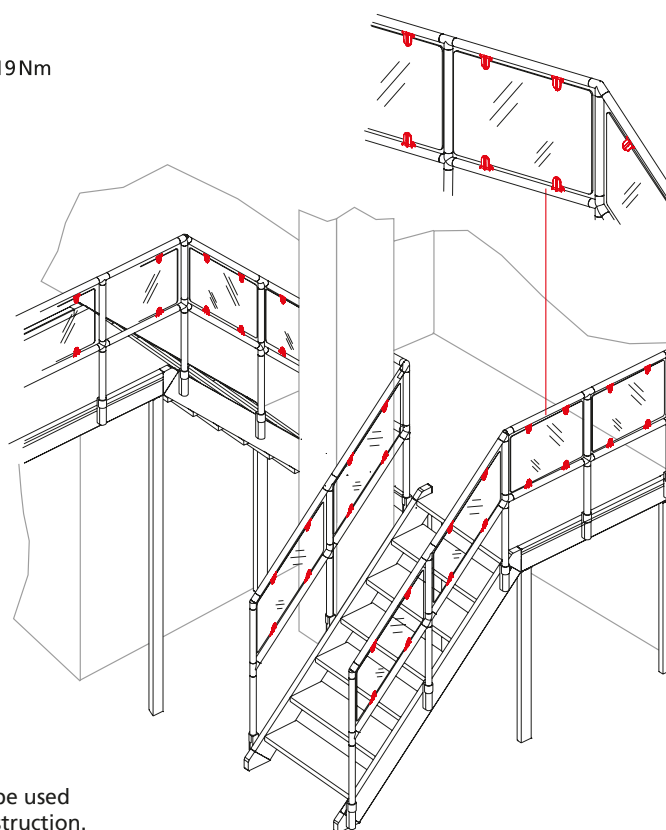
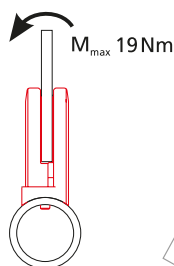

Attention:
 the support can only be used
 in a closed frame construction.

Accessories

On request:

- ITAS elements in various RAL colours

- The angle plate is fixed to the corner of the stair cross beam at 90° degrees.

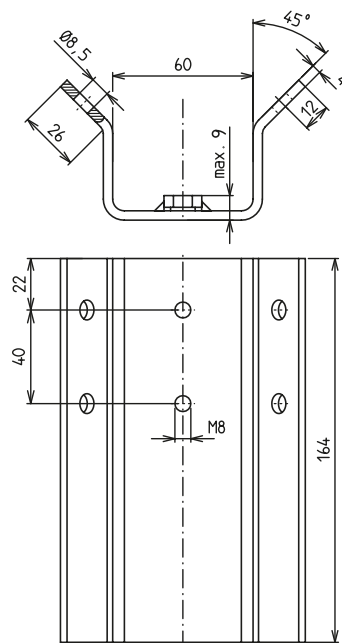
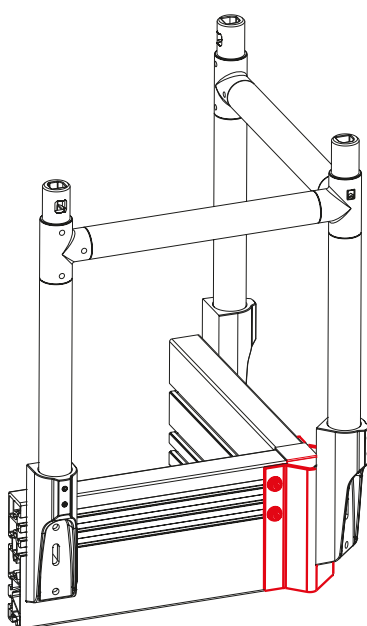

Angle plate for TGHF

Code No.	Type
96701	Angle plate

Accessories



Material: AlMgSi 0,5 F22, natural

$I_x = 16 \text{ cm}^4$
 $I_y = 1003 \text{ cm}^4$
 $W_x = 7 \text{ cm}^3$
 $W_y = 80 \text{ cm}^3$

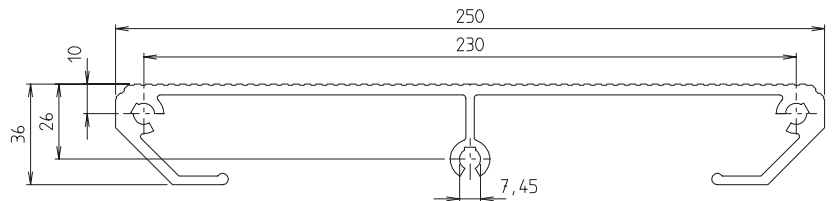
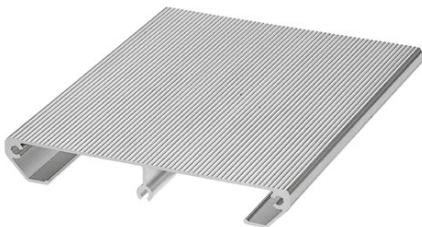

Step profile

Code No.	Type	Version	m [g]
4525000	Step profile	Cut max. 6000 mm	3621 / m
4525001	Step profile	Bar at 6000 mm	3621 / m

Features:

- An endless step profile made of extruded aluminium which is cut to the step width desired.
- All stairs with a gradient angle of between 30 and 40 degrees are in accordance with standard DIN EN ISO 144122-:201610. This includes treads, height, overlap and width. They are also compliant with UVV (workers safety regulations and accident prevention rules).
- Threaded channels have been prepared to ensure thar side plates can be fixed with standard M8 screws see p. 251).
- This step profile can, of course, also be used as a platform element.

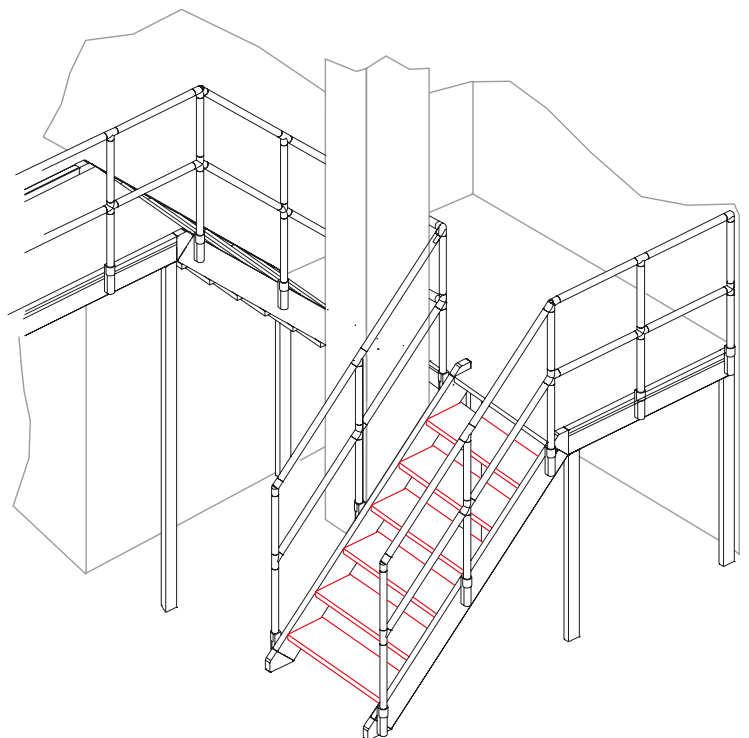



Features:

- The code n° contains a complete fixing set for the fitting of the side plate to the step profile (see p. 250).
- The arrangement of the holes and slots enables alignment of the step when it is fitted to the stair cross beam profile. The side plate serves as an end piece to the step width chosen by the customer.

Material: AlMgSi 0,5 F22, natural

Thickness t = 5 mm

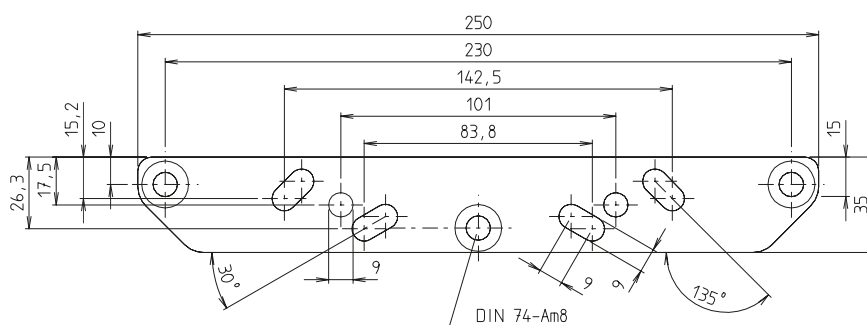

Site plate

Code No.	Type	m [g]
93700	Side plate	164

Accessories

Features:

- This joint permits the construction of 38°, 45° and 60° angles.
- The arrangement of holes guarantees the fixing of this joint to the stair cross beam profile (see p. 249) with set screws quality 8.8 and hexagonal nuts.
- The centre spigot is for the fixing of the last step in the transition from stair to platform.



Fixing stairs / floor with stair joint 45°



Fixing stairs / floor with mitre cut 38°, 60°



Fixing stairs / working platform with stair joint 38°, 45°, 60°

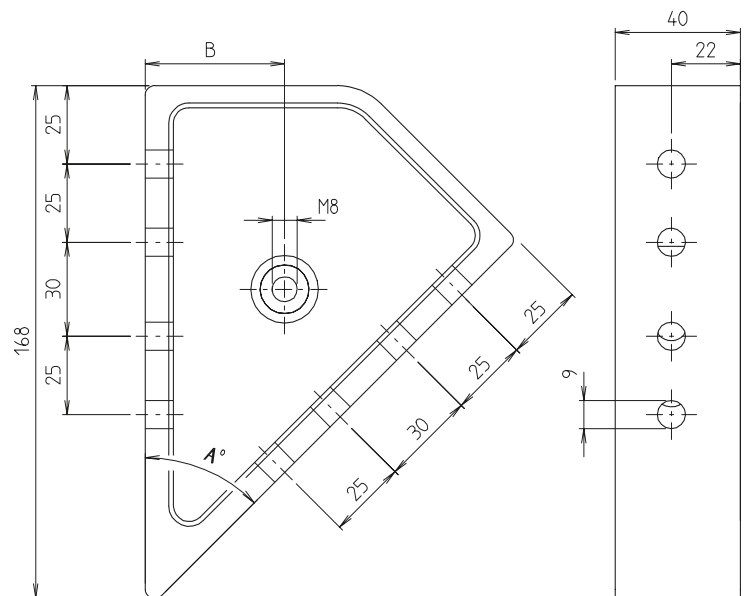

Stair joint

Code No.	Type	A	B	Material	m [g]
93807	Stair joint 38° fixing step-platform	38°	36,15	Gk AlSi 12	436
93810	Stair joint 45° fixing step-platform	45°	44,5	Gk AlSi 12	500
93811	Stair joint 45° fixing floor step	45°	44,5	Gk AlSi 12	500
93820	Stair joint 60° fixing step-platform	60°	60,5	Gk AlSi 12	563



Order instruction:

- Purchase only in lot sizes and a multiple of that, see product table below

Material: AlMgSi 0,5 F22

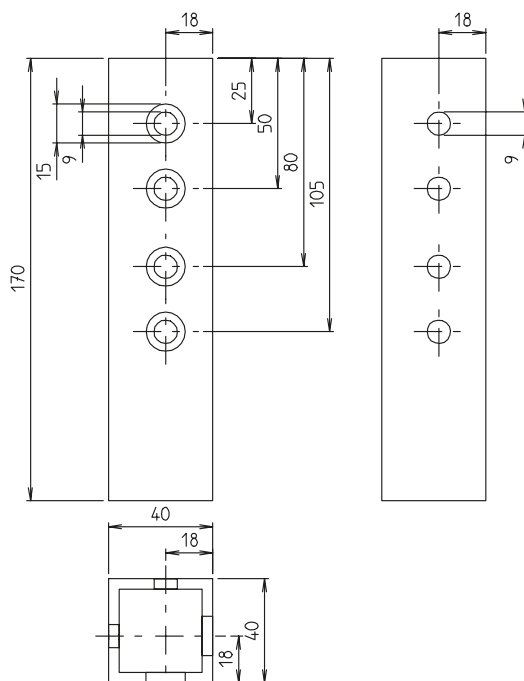
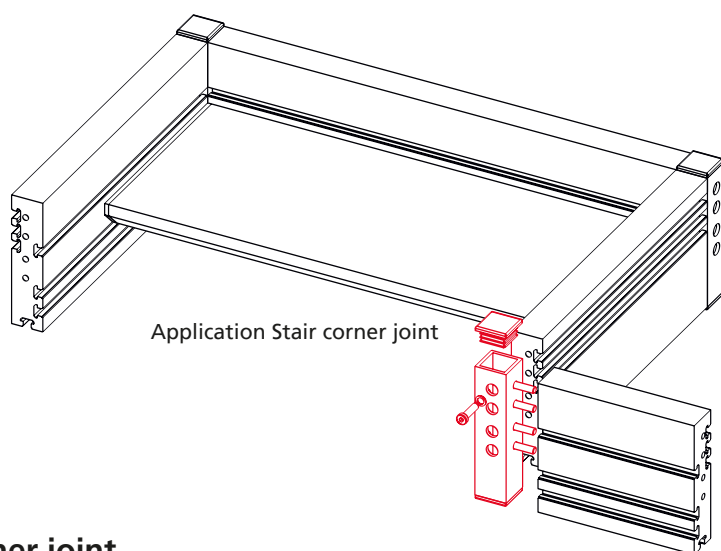

The illustration shows a "left" version . The right version is the mirror-image.

Stair corner joint

Code No.	Type	m [g]
93821	Stair corner joint right-hand	242
93822	Stair corner joint left-hand	242

Tools

Code No.	Type	lot sizes	Application
91804	Compl.clamping lever set	-	Spare parts for internal tension system (clamping screw, clamping rocker, thrust pad, screw cap)
90404	Stopper	10, 20, 30... pcs	for quick change system

Industrial stairs and working platforms



A circulating podium, in an assembly hall, with multiple access points.



Staircase between two operating platforms.



Enquiry form ITAS – Industrial stairs and working platforms

Fax: 49 571 9335-139 Phone: 49 571 9335-0
e-mail: anfrage.vertrieb@rk-online.de

Company:..... Customer no:.....
 Adress:
 Phone:..... Telefax:.....
 Responsible:..... E-Mail:
 Remarks:

Working platform

Constructions are made of aluminium components with non-slip step profiles and smooth connections between handrailing components allowing a complete modular design.

Procedure:

Please fill in points 1 to 4, so that we are able to send you the quotation as soon as possible.
 A layout of your details with possible constructional suggestions from our company will be placed at your disposal upon request.

1. Application

fixed platforms

2. Delivery

unassembled

pre-assembled parts

3. Technical data

Load: max. 150 kg/m²

Step width:mm

Length of platform:mm

Height of platform:mm

Angle of inclination (see type of railing) ⇒

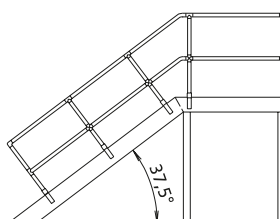

Railing 38°

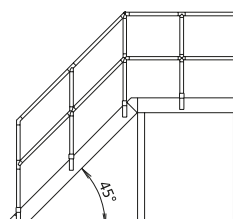

Railing 45°

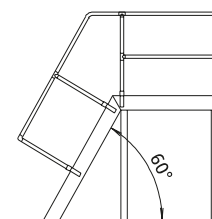

Railing 60°

4. Angle of inclination (see type of railing)

Stairs

Railing*

Stairs mit platform

Railing*

Bridge

Railing*

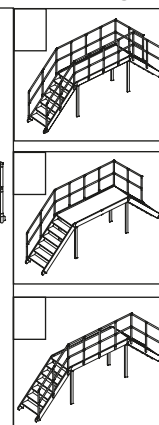
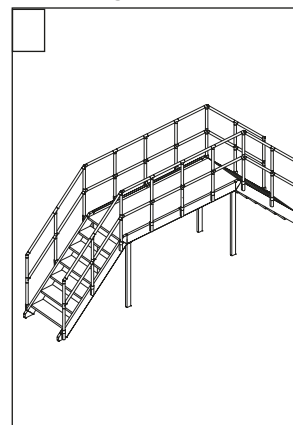
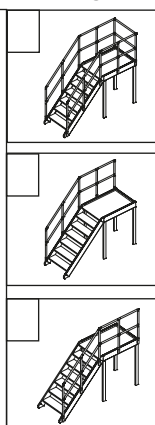
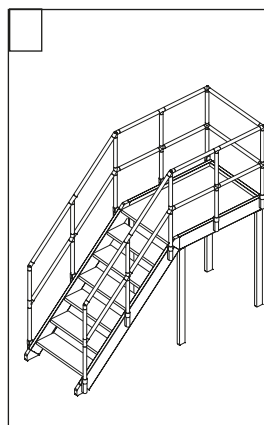
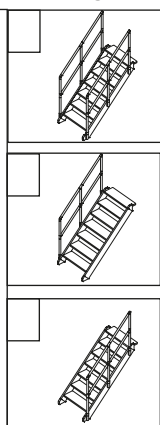
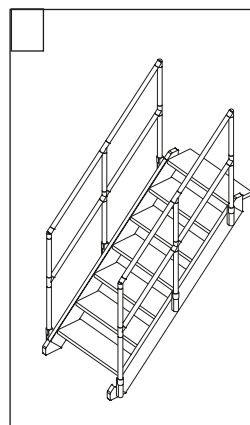

*In case of a height of more than 1 m it is necessary to assemble railings onto the stairs and platforms.

