

Technology that moves

HAHN Gasfedern, a pioneer in gas spring technology, has been one of the leading companies in the industry since 1966. The company has developed into the technology leader and trendsetter of the industry with its innovative products and uncompromising quality.

- ▶ We make the highest demands of our products. All our products are developed, manufactured and delivered according to the most strict quality standards. Specially trained employees monitor the adherence to our quality criteria in every phase of the production process. We are certified according to DIN ISO 9001, DIN ISO 14001, DIN EN ISO 50001. Our manufacturing is consistent with Reach and RoHS guidelines. We are a member of the trademark association EDELSTAHL Rostfrei and also place immense value on strict quality standards when selecting our sales and service partners.

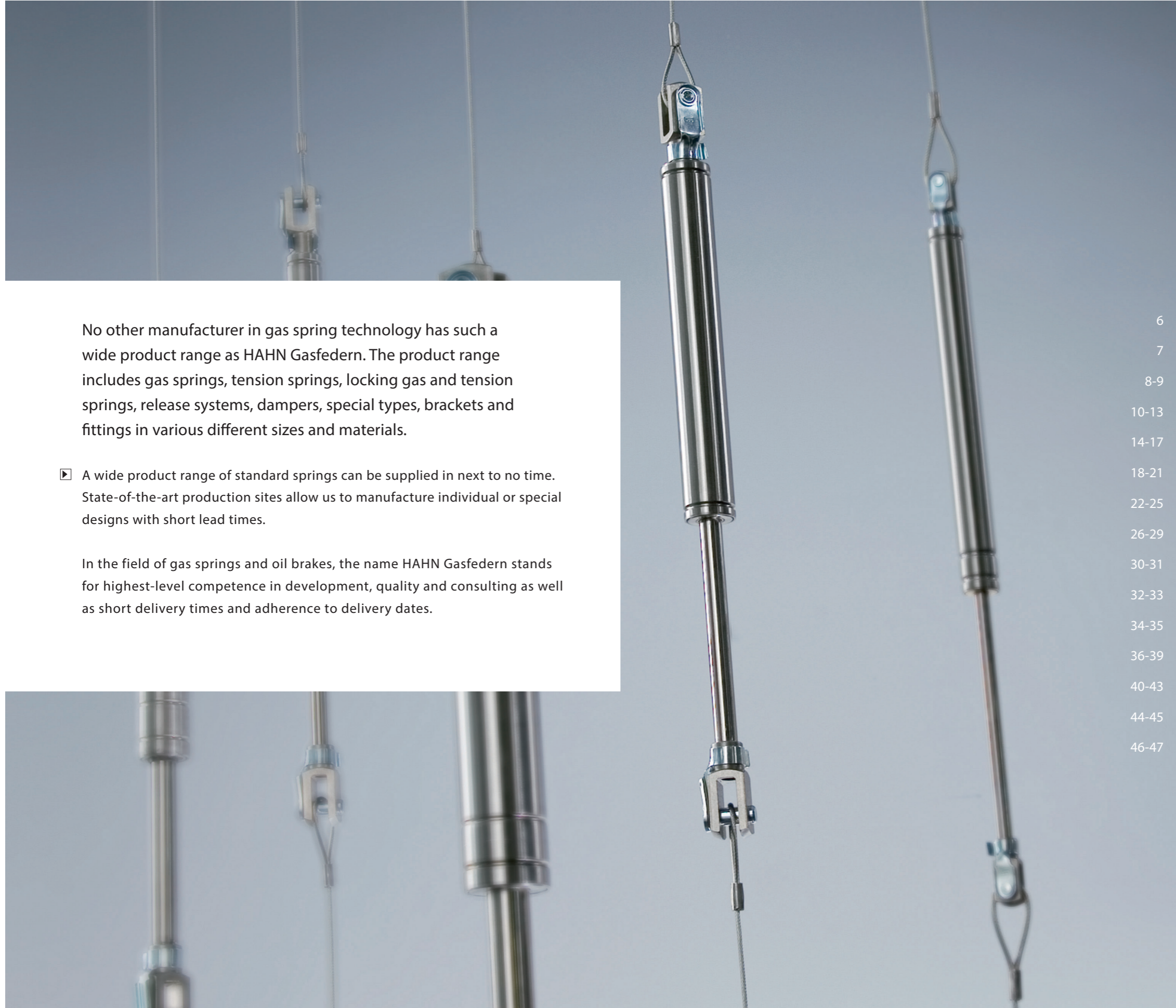



No other manufacturer in gas spring technology has such a wide product range as HAHN Gasfedern. The product range includes gas springs, tension springs, locking gas and tension springs, release systems, dampers, special types, brackets and fittings in various different sizes and materials.

- ▶ A wide product range of standard springs can be supplied in next to no time. State-of-the-art production sites allow us to manufacture individual or special designs with short lead times.

In the field of gas springs and oil brakes, the name HAHN Gasfedern stands for highest-level competence in development, quality and consulting as well as short delivery times and adherence to delivery dates.

Content

6	Design and function
7	Order system
8-9	Customer Solution
10-13	Gas springs
14-17	Tension springs
18-21	Locking gas springs
22-25	Release systems
26-29	Oil dampers
30-31	Double-stroke springs
32-33	Sliding Door Damper (SDD)
34-35	Gas springs with ballpoint pen principle
36-39	Fittings
40-43	Brackets
44-45	Extras and technical instructions
46-47	Global sales partners

Design and function of HAHN gas springs

HAHN gas springs are used for all applications that require controlled moving and braking of weights without having to apply strong forces.

- ▶ Gas springs by HAHN are used in virtually every field today. In furniture industry, engineering, for sports, leisure and home appliances, in medical engineering and other areas of industrial and private use. For special applications in medical engineering, the chemicals and food industry and ship-building, we manufacture our products in stainless steel. We produce all types and series in AISI 303/304 and AISI 316L/316Ti and are the market leader in this area. Our gas springs and oil brakes in AISI 316L/316Ti are stainless and resistant to chemicals.

This catalogue will provide you with an overview of our broad product range. You can find more detailed information and data sheets on the individual types, series and qualities on the Internet at www.hahn-gasfedern.de. Additional information and notes can be found in the technical instructions on page 45 of this catalogue or in the Internet.

The order system described here will help you compose the product you require. The order code corresponds to our item designation. The employees of HAHN Gasfedern and your local sales partners (see page 46) will be glad to help you find the right products and support you in every way.

One of the special strengths of HAHN Gasfedern is the development of customer-specific solutions. A highly-qualified team, state-of-the-art CAD workplaces and high-quality machinery allow us to find solutions for your application challenges and to realise them with short lead times.

Order system

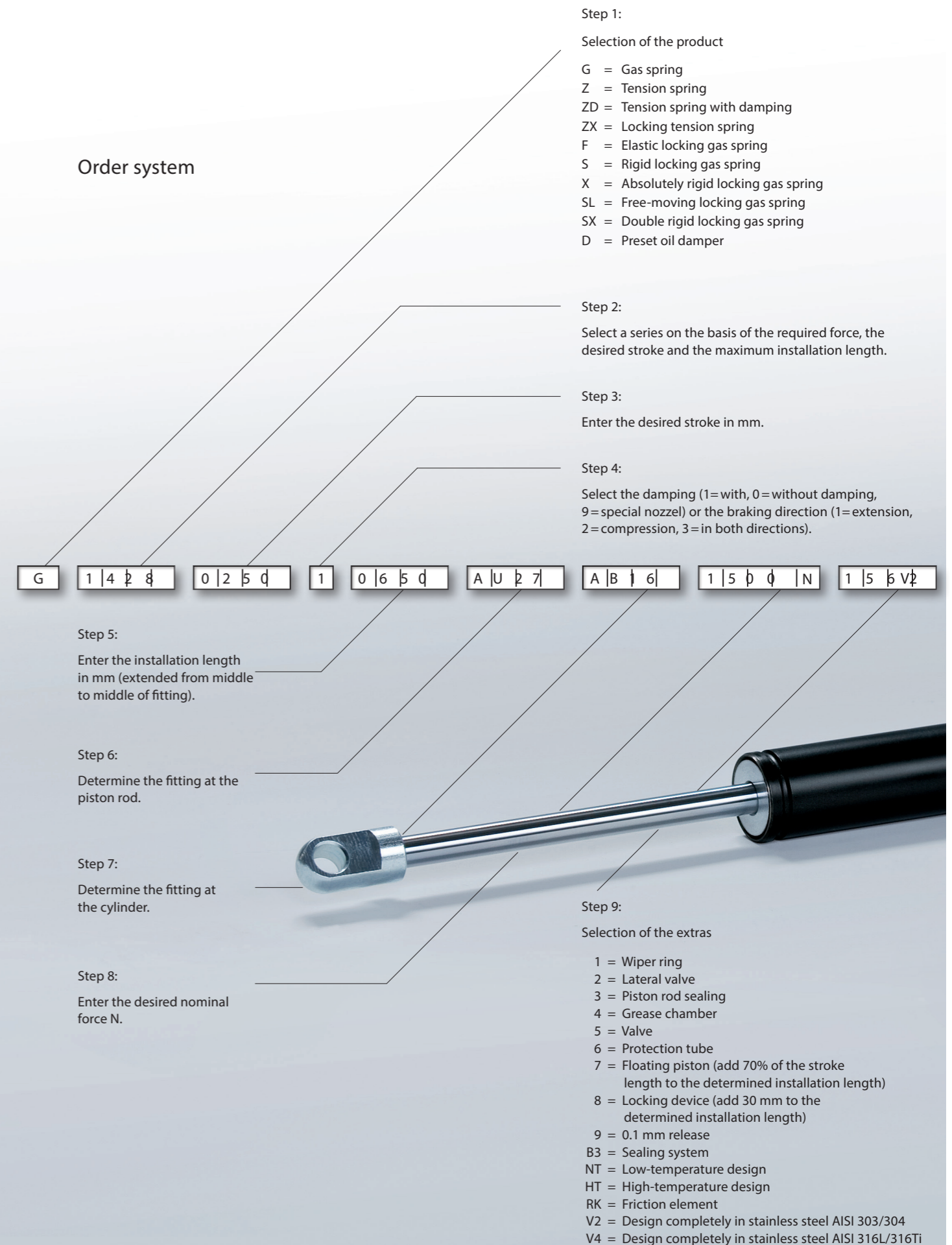



▣ A special strength of HAHN Gasfedern GmbH lies in the development of unique high-quality solutions. In order to meet these demands in the long term, we support our dealers with tailor-made service products such as filling systems, filling cases, regulators or valves for individual force adjustment. A further milestone on the way to comprehensive customer support is our convenient calculation program.

NEW software, numerous advantages

- Design of complex applications (multi-joint hinges)
- Simulation and calculation of different gas spring applications
- Top sellers can be deposited
- No Internet connection required



Filling system



Valve



Regulator



Filling case

▣ Due to our wide range of materials, our products are at home in every field of application.

Steel, hard chrome

Features
Standard Material

Application area
as well as in any field

Stainless steel V2A AISI 304

Features
stainless steel version in AISI 303/304

Application area
Chemical and food industry
Ship and yacht building

Optionally, a FDA regulations corresponding to oil is used.

Stainless steel V4A AISI 316

Features
stainless steel version in AISI 316L/316Ti

Application area
medical technology

Optionally, a FDA regulations corresponding to oil is used.

HAHN Gasfedern provides several decades of experience in gas spring technology. The first HAHN gas springs were already developed and produced in 1966.

- ▶ Today we manufacture 17 different series in steel and stainless steel AISI 303/304 and AISI 316L/316Ti. The HAHN modular system provides more than 5 million variants. At the same time, we are the manufacturers of the smallest gas spring in the world, market leaders in the sector of stainless-steel gas springs and the only manufacturers of special series such as double-stroke and telescopic gas springs.

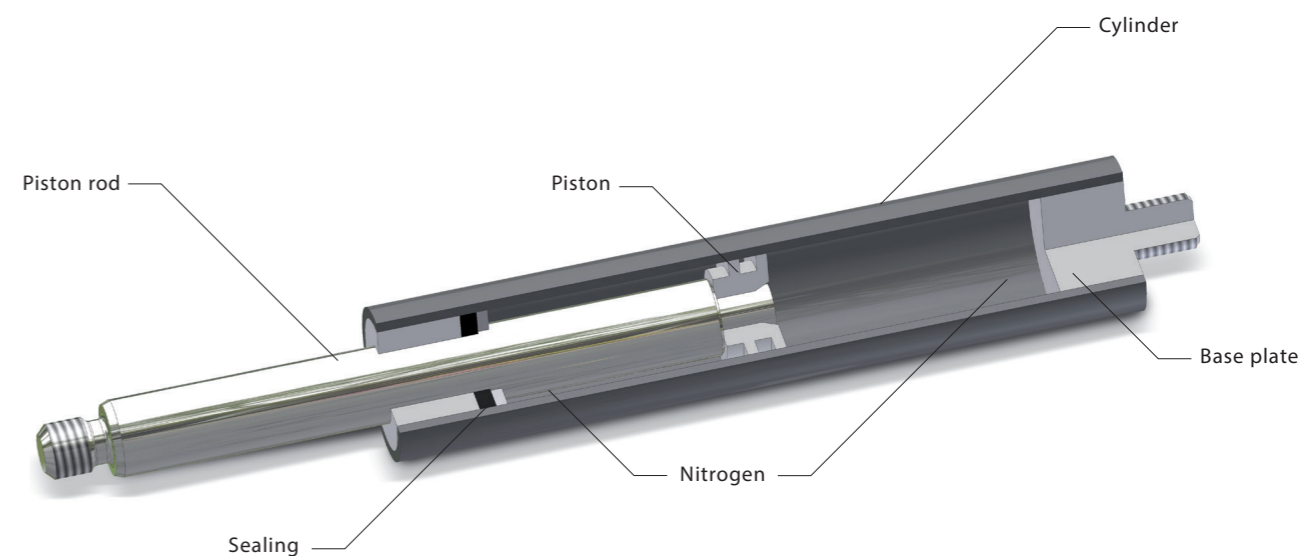

- ▶ HAHN gas springs are hydropneumatic, closed and maintenance-free adjustable elements. The spring force F_1 results from the internal pressure (160 bars without load at the most) in the cylinder, which is generated by the filling medium nitrogen. On the gas spring, this pressure is applied to the cross-section of the piston rod. When no load is applied, the piston rod always is extended.

By pushing in the piston rod, the volume in the cylinder is reduced, and the gas is compressed. Thus the gas spring force increases (progression) depending on the diameter of the piston rod and the volume of the cylinder. HAHN gas springs contain an oil filling for lubrication and end damping.

HAHN gas springs are available in steel, in AISI 303/304 and AISI 316L/316Ti.

Gas springs

State-of-the-art production sites with CNC-controlled machines are the basis for ultimate safety, quality and durability.

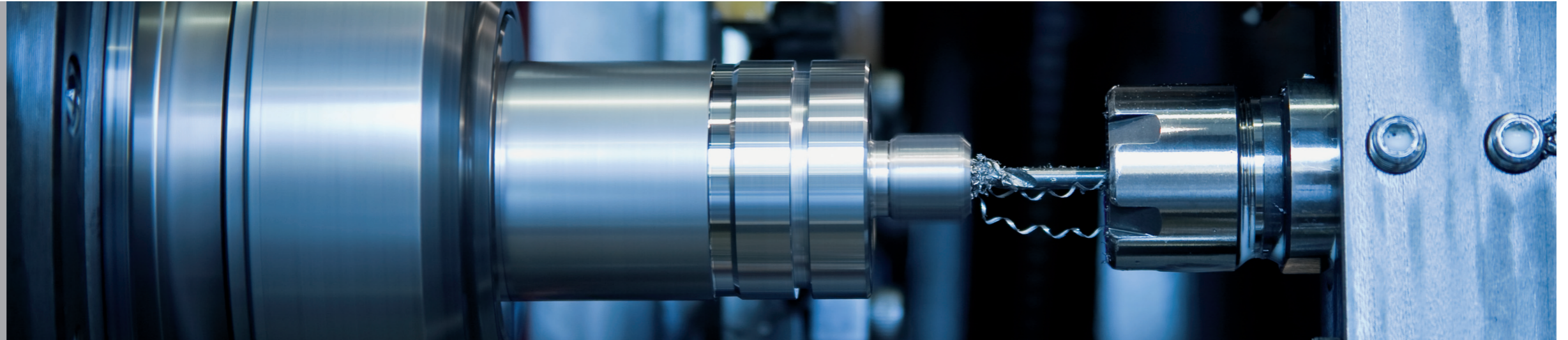

Standard product range

Type	Ø Rod	Ø Cylinder	Stroke	Standard length	Extension force	Progression
G 02-06	2 mm	6 mm	5 - 50 mm	2 x stroke + 20	5 - 40 N	20 %
G 03-08	3 mm	8 mm	10 - 80 mm	2 x stroke + 32	5 - 100 N	30 %
G 03-10	3 mm	10 mm	10 - 80 mm	2 x stroke + 32	5 - 100 N	20 %
G 04-12	4 mm	12 mm	30 - 180 mm	2 x stroke + 32	10 - 180 N	25 %
G 06-15	6 mm	15.6 mm	20 - 300 mm	2 x stroke + 55	40 - 400 N	22 %
G 06-19	6 mm	19 mm	20 - 300 mm	2 x stroke + 55	40 - 400 N	17 %
G 08-19	8 mm	19 mm	40 - 500 mm	2 x stroke + 70	50 - 800 N	30 %
G 08-23	8 mm	23 mm	40 - 500 mm	2 x stroke + 70	50 - 700 N	18 %
G 10-23	10 mm	23 mm	40 - 500 mm	2 x stroke + 70	100 - 1200 N	30 %
G 10-28	10 mm	28 mm	40 - 500 mm	2 x stroke + 70	100 - 1200 N	20 %
G 10-40	10 mm	40 mm	30 - 500 mm	2 x stroke + 100	150 - 1200 N	8 %
G 14-28	14 mm	28 mm	50 - 600 mm	2 x stroke + 107	150 - 2500 N	40 %
G 14-40	14 mm	40 mm	50 - 600 mm	2 x stroke + 100	150 - 2500 N	16 %
G 20-40	20 mm	40 mm	50 - 600 mm	2 x stroke + 138	300 - 5000 N	40 %
G 22-40	22 mm	40 mm	50 - 1000 mm	2 x stroke + 138	500 - 6000 N	43 %
G 25-55	25 mm	55 mm	100 - 1000 mm	2 x stroke + 140	500 - 7500 N	40 %
G 30-65	30 mm	65 mm	100 - 1000 mm	2 x stroke + 160	750 - 10000 N	35 %

Thread rod	Thread cylinder	Extras	Steel	AISI 303/304	AISI 316L/316Ti
M 2	M 2	5	•	-	•
M 3.5	M 3.5	5, 6	•	-	•
M 3.5	M 3.5	5, 6	•	-	•
M 3.5	M 3.5	5, 6, 7	•	-	•
M 5	M 5	4, 5, 6, 7, NT, RK, HT	•	•	•
M 5	M 8	2, 4, 5, 6, 7, NT	•	•	-
M 8	M 8	1, 2, 4, 5, 6, 7, 8, NT, HT	•	•	•
M 8	M 8	2, 4, 5, 6, 7	•	o. r.	o. r.
M 8	M 8	1, 2, 4, 5, 6, 7, 8, B3, NT, HT, RK	•	•	•
M 8	M 8	2, 4, 5, 6, 7, 8, B3, NT, HT	•	•	•
M 8	M 14 x 1.5	2, 4, 5, 6, 7	•	•	•
M 10	M 10	1, 2, 4, 5, 6, 7, 8, NT, HT	•	•	•
M 10	M 10	1, 2, 4, 5, 6, 7, 8, B3	•	•	o. r.
M 14 x 1.5	M 14 x 1.5	1, 2, 4, 6, 7, B3, NT, HT	•	•	•
M 14 x 1.5	M 14 x 1.5	1, 2, 4, 6, 7	•	•	-
M 20 x 1.5	M 20 x 1.5	2, 6	•	-	-
M 24 x 2	M 24 x 2	2, 6	•	-	-

Tension springs



HAHN tension springs are used for all applications where normal gas springs cannot be used for lack of space.

- ▣ Tension springs work in the opposite way as gas springs, i.e. the piston rod is pulled towards the inside by means of the gas pressure in the cylinder. The spring force F_1 results from the internal pressure (160 bars without load at the most) in the cylinder, which is generated by the filling medium nitrogen. In the tension spring, the piston ring area between the piston rod and the inside cylinder diameter is decisive. When no load is applied, the piston rod always is compressed. The tension springs of series 'Z' have no damping. The series ZD is available with damping and series ZX is available as locking tension spring.

HAHN tension springs are available in steel, in AISI 303/304 and AISI 316L/316Ti.

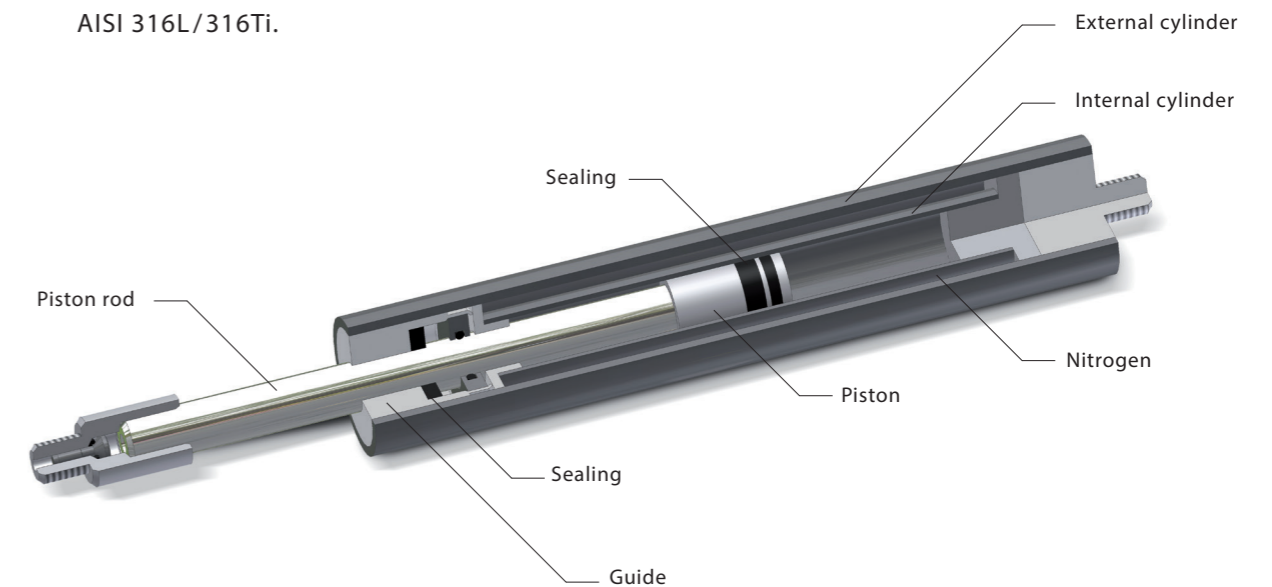

Since 2017 HAHN offers the tension spring in the turnover variant. Which, due to its short overall length, can be used in areas of application where size is limited.

The turnover variant is available in type Z 06 19 and 10 28.

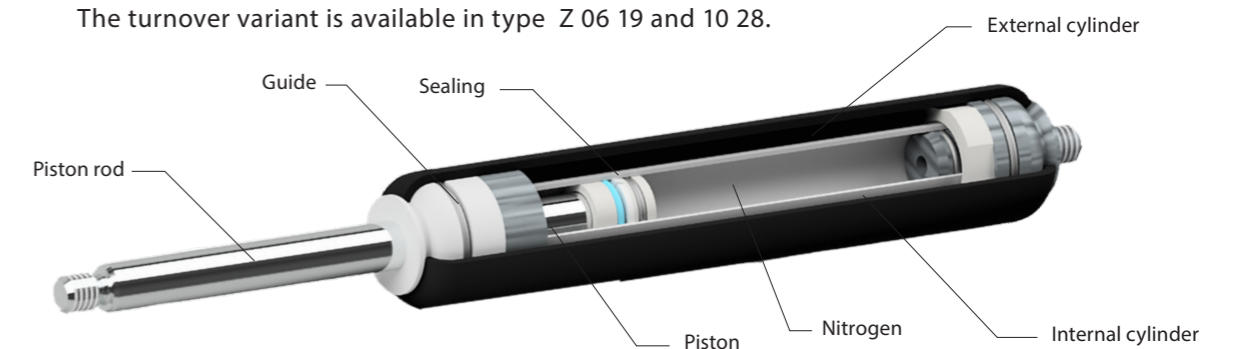

Tension springs

Experienced engineers and technicians support you in implementing your projects and develop optimum solutions.

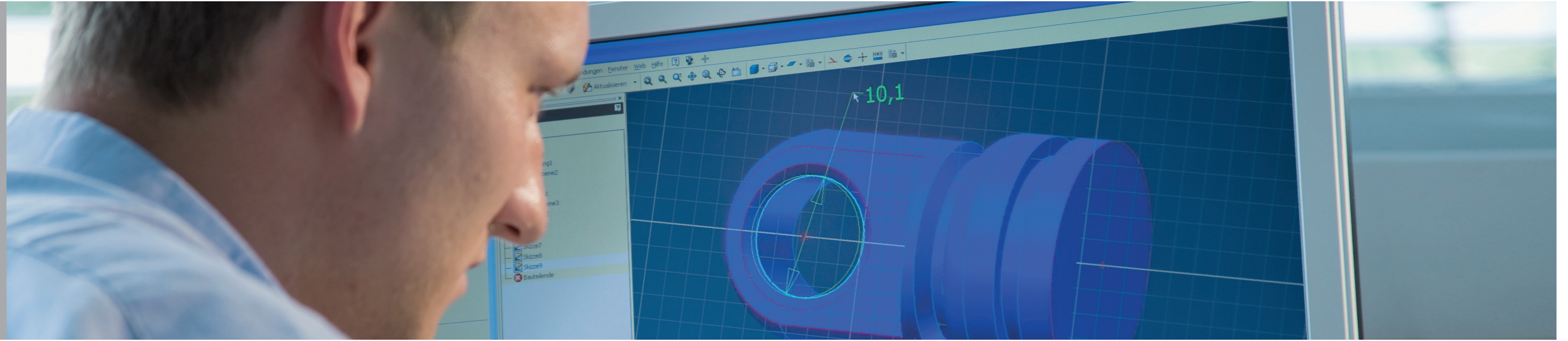

Standard product range

Type	Ø Rod	Ø Cylinder	Stroke	Standard length	Tension force	Progression
Z 04-15	4 mm	15 mm	20 - 200 mm	2 x stroke + 63	50 - 300 N	22 %
Z 06-19	6 mm	19 mm	30 - 400 mm	2 x stroke + 100	30 - 350 N	29 %
Z 10-28	10 mm	28 mm	60 - 600 mm	2 x stroke + 100	150 - 1200 N	20 %
Z 10-40	10 mm	40 mm	10 - 590 mm	2 x stroke + 150	200 - 2000 N	78 %
Z 28-40	28 mm	40 mm	50 - 700 mm	2.5 x stroke + 125	500 - 5000 N	40 %

Thread rod	Thread cylinder	Extras	Steel	AISI 303/304	AISI 316L/316 Ti
M 3.5	M 3.5	-	•	-	•
M 5	M 5	4, 6, NT	•	•	•
M 8	M 8	2, 4, 6, NT, HT	•	•	•
M 14 x 1.5	M 14 x 1.5	4, 6	•	•	•
M 14 x 1.5	M 14 x 1.5	2, 6	•	•	o. r.

Tension spring with damping

Type	Ø Rod	Ø Cylinder	Stroke	Standard length	Tension force	Progression
ZD 10-28	10 mm	28 mm	20 - 600 mm	3 x stroke + 90	100 - 1200 N	36 %

Thread rod	Thread cylinder	Extras	Steel	AISI 303/304	AISI 316L/316 Ti
M 8	M 8	4, 6	•	o. r.	o. r.

Tension spring with locking

Type	Ø Rod	Ø Cylinder	Stroke	Standard length	Tension force	Progression
ZX 10-28	*	*	*	*	*	*

Thread rod	Thread cylinder	Extras	Steel	AISI 303/304	AISI 316L/316 Ti
*	*	*	*	*	*

* Technical design on request

Locking gas springs



Hahn locking gas springs can be locked steplessly along the complete stroke. Furniture, vehicle seats, flaps, etc. can be locked in the desired position and readjusted.

- ▶ When the release is actuated, the piston valve opens. In the elastic locking gas springs it is nitrogen, in the rigid locking gas springs it is oil that flows through the piston, and the piston rod is extended or can be pushed in. When the release is actuated, the valve in the gas spring closes automatically, and the piston rod is locked in the desired position. Hahn Gasfedern adjusts the locking type exactly to the individual circumstances. The customers can choose between elastic locking, rigid locking, absolutely rigid locking, free-moving locking and locking in both directions.

Hahn locking gas springs are available in steel, in AISI 303/304 and in AISI 316L/316Ti.

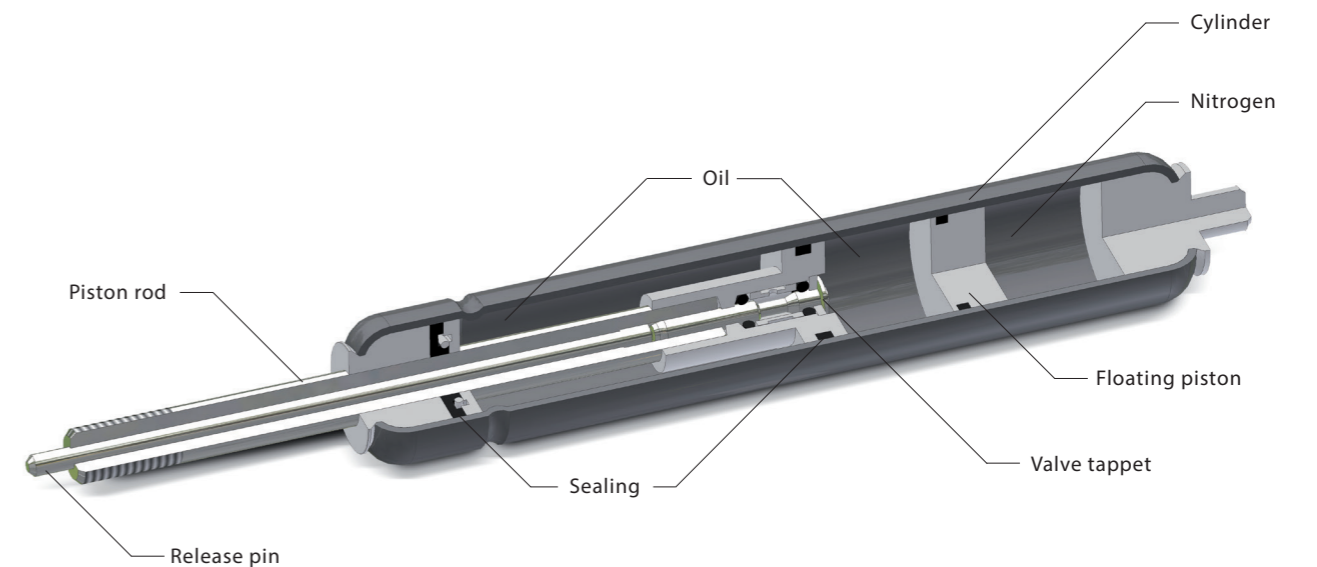

Locking gas springs

Elastic locking gas springs

Type	Ø Rod	Ø Cylinder	Stroke	Standard length	Extension force	Progression
F 06-19	6 mm	19 mm	40 - 150 mm	2.4 x stroke + 70	60 - 400 N	15 %
F 10-23	10 mm	23 mm	20 - 400 mm	2 x stroke + 90	100 - 1200 N	29 %
F 10-28	10 mm	28 mm	20 - 400 mm	2 x stroke + 90	100 - 1200 N	17 %
F 10-40	10 mm	40 mm	20 - 400 mm	2 x stroke + 90	100 - 1200 N	8 %
F 14-40	14 mm	40 mm	20 - 500 mm	2 x stroke + 100	100 - 2500 N	17 %

Thread rod	Thread cylinder	Locking force tension	Locking force compression	Release way	Extras	Steel	AISI 303/304	AISI 316L/316Ti
M 6 x 0.75	M 8	-	-	2 - 4 mm	4, 5	•	•	o. r.
M 10 x 1	M 8	-	-	2 - 4 mm	3, 4, 5, 6, 9	•	•	o. r.
M 10 x 1	M 8	-	-	2 - 4 mm	3, 4, 5, 6, 9, B3	•	•	o. r.
M 10 x 1	M 10	-	-	2 - 4 mm	3, 4, 6	•	•	o. r.
M 14 x 1.5	M 14 x 1.5	-	-	2 - 4 mm	1, 2, 4, 6	•	-	-

Rigid locking gas springs

Type	Ø Rod	Ø Cylinder	Stroke	Standard length	Extension force	Progression
S 06-19	6 mm	19 mm	30 - 150 mm	2.4 x stroke + 65	60 - 400 N	41 %
S 08-23	8 mm	23 mm	60 - 300 mm	2,54 x stroke + 77	60 - 700 N	30 %
S 10-23	10 mm	23 mm	20 - 400 mm	2.5 x stroke + 90	150 - 1200 N	50 %
S 10-28	10 mm	28 mm	20 - 400 mm	2.4 x stroke + 80	180 - 1200 N	47 %
S 10-40	10 mm	40 mm	20 - 400 mm	2.2 x stroke + 100	100 - 1200 N	53 %
S 14-40	14 mm	40 mm	20 - 500 mm	2.4 x stroke + 95	100 - 2500 N	41 %

Thread rod	Thread cylinder	Locking force tension	Locking force compression	Release way	Extras	Steel	AISI 303/304	AISI 316L/316Ti
M 6 x 0.75	M 8	3 x F1	2 x F1	2 - 4 mm	5	•	•	o. r.
M 8	M 8	5000 N	6,25 x F1	2 - 4 mm	5	•	-	-
M 10 x 1	M 8	max. 3000 N	4 x F1	2 - 4 mm	3, 4, 5, 6, 9	•	•	o. r.
M 10 x 1	M 8	max. 3000 N	5,5 x F1	2 - 4 mm	3, 4, 5, 6, 9	•	•	o. r.
M 10 x 1	M 10	5 x F1	10 x F1	2 - 4 mm	3, 4, 6	•	•	o. r.
M 14 x 1.5	M 14 x 1.5	2 x F1	5 x F1	2 - 4 mm	1, 2, 4, 6	•	-	-

Absolut (on compression) rigid locking gas springs

Type	Ø Rod	Ø Cylinder	Stroke	Standard length	Extension force	Progression
X 10-23	10 mm	23 mm	20 - 400 mm	2.6 x stroke + 80	150 - 1000 N	34 %
X 10-28	10 mm	28 mm	20 - 400 mm	2.6 x stroke + 80	150 - 1000 N	20 %
X 10-40	10 mm	40 mm	20 - 400 mm	2.4 x stroke + 84	150 - 1200 N	8 %
X 14-40	14 mm	40 mm	20 - 500 mm	3.7 x stroke + 84	150 - 1200 N	12 %

Thread rod	Thread cylinder	Locking force tension	Locking force compression	Release way	Extras	Steel	AISI 303/304	AISI 316L/316Ti
M 10 x 1	M 8	2 x F1	10,000 N - 5 x F1	2 - 4 mm	3, 6	•	o. r.	o. r.
M 10 x 1	M 8	2 x F1	10,000 N	2 - 4 mm	3, 6, 9	•	o. r.	o. r.
M 10 x 1	M 10	12 x F1	10,000 N	2 - 4 mm	3, 6	•	o. r.	o. r.
M 14 x 1.5	M 14 x 1.5	5.6 x F1	10,000 N	2 - 4 mm	6	•	-	-

Free-moving locking gas springs

Type	Ø Rod	Ø Cylinder	Stroke	Standard length	Extension force	Progression
SL 10-28	10 mm	28 mm	20 - 400 mm	2.4 x stroke + 80	150 - 1200 N	25 %

Thread rod	Thread cylinder	Locking force tension	Locking force compression	Release way	Extras	Steel	AISI 303/304	AISI 316L/316Ti
M 10 x 1	M 8	max. 3000 N	5.5 x F1	2 - 4 mm	3, 6, 9	•	•	o. r.

Double locking (on compression + extension) gas springs

Type	Ø Rod	Ø Cylinder	Stroke	Standard length	Extension force	Progression
SX 10-23	*	*	*	*	*	*
SX 10-28	*	*	*	*	*	*

Thread rod	Thread cylinder	Locking force tension	Locking force compression	Release way	Extras	Steel	AISI 303/304	AISI 316L/316Ti
*	*	*	*	*	*	*	*	*
*	*	*	*	*	*	*	*	*

* Technical design on request

Lever releases for locking gas springs

We offer a wide range of lever releases for the direct release and locking of HAHN locking gas springs. Depending of the respective application, the release can be effected towards the spring, away from the spring or variably on both sides and in every direction.

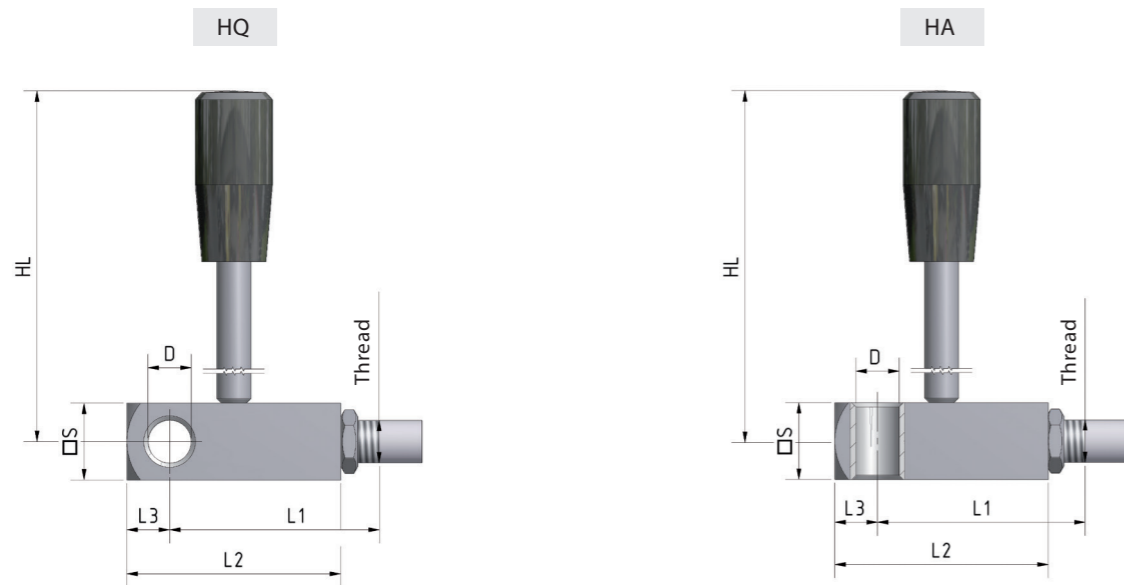

Type	Thread	L1	L2	L3	S	D	HL
HA24	M 6 x 0.75	30 mm	27 mm	6 mm	10 mm	6.1 mm	70 mm*
HA40	M 10 x 1	40 mm	42.5 mm	7.5 mm	15 mm	8.1 mm	120 mm*
HQ40	M 10 x 1	40 mm	42.5 mm	7.5 mm	15 mm	8.1 mm	120 mm*
HA47	M 14 x 1.5	47 mm	50 mm	10 mm	18 mm	10.1 mm	120 mm*
HQ47	M 14 x 1.5	47 mm	50 mm	10 mm	18 mm	10.1 mm	120 mm*

* Other lever lengths on request

Release head Aluminium anodised
 Operating lever Steel zinc-plated (for HA24, lever is steel/black oxide)
 Cylinder button Plastic (HA24 without cylinder button)

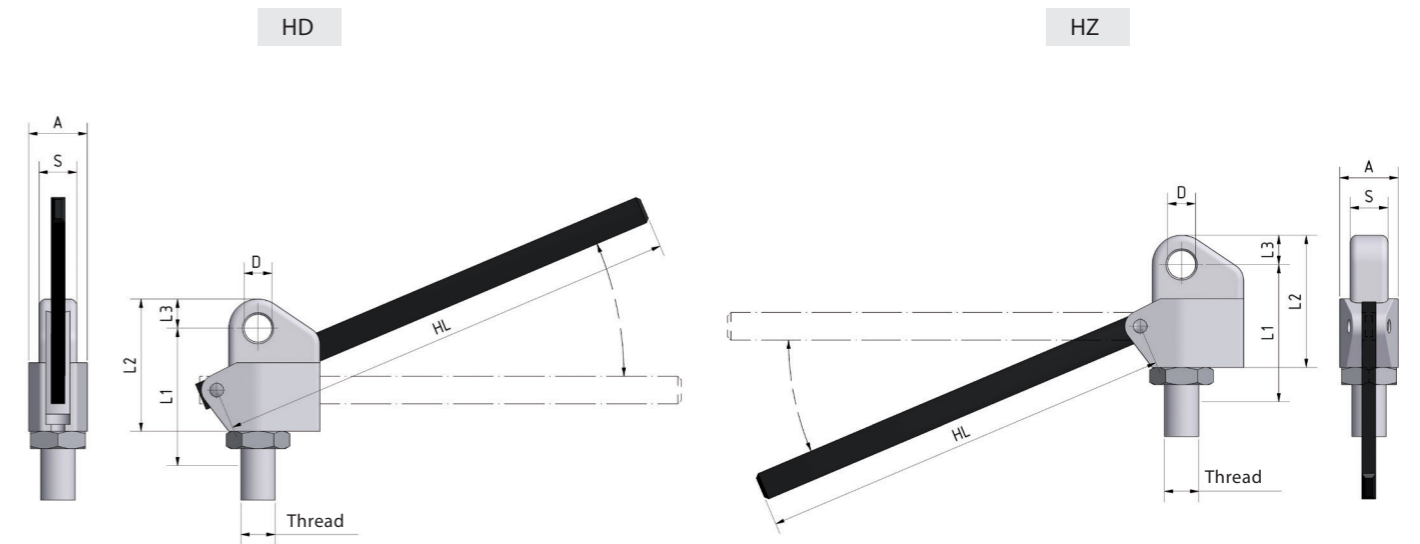

Type	Thread	L1	L2	L3	A	S	D	HL
HD35-6	M 6 x 0.75	40 mm	38.5 mm	8.5 mm	17 mm	11 mm	8.1 mm	130 mm*
HD35-10	M 10 x 1	40 mm	38.5 mm	8.5 mm	17 mm	11 mm	8.1 mm	130 mm*
HZ35-6	M 6 x 0.75	40 mm	38.5 mm	8.5 mm	17 mm	11 mm	8.1 mm	130 mm*
HZ35-10	M 10 x 1	40 mm	38.5 mm	8.5 mm	17 mm	11 mm	8.1 mm	130 mm*

* Other lever lengths on request

Release head Aluminium die casting
 Operating lever Steel/black oxide

Bowden cable releases for locking gas springs

Hahn locking gas springs can also be mechanically released and locked over larger distances by means of Bowden cable releases. They are characterised by optimum force transmission, high durability and absolute operational reliability.

Release head Aluminium anodised
 Operating lever Steel zinc-plated
 Shoe Steel plate zinc-plated

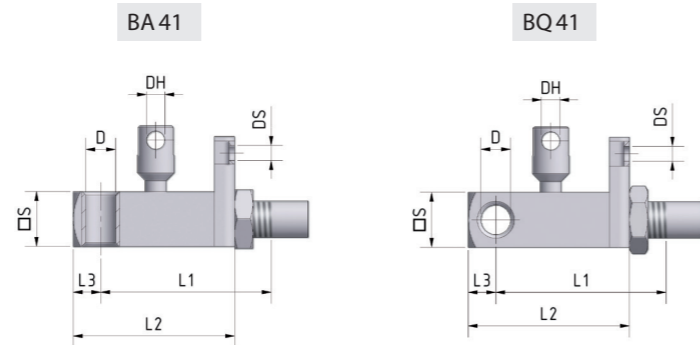

Type	Thread	L1	L2	L3	S	D	DH	DS
BA 41	M 10 x 1	41 mm	43.5 mm	7.5 mm	15 mm	8.1 mm	5.1 mm	4.1 mm
BQ 41	M 10 x 1	41 mm	43.5 mm	7.5 mm	15 mm	8.1 mm	5.1 mm	4.1 mm

Release head Aluminium die casting
 Operating lever Plastic

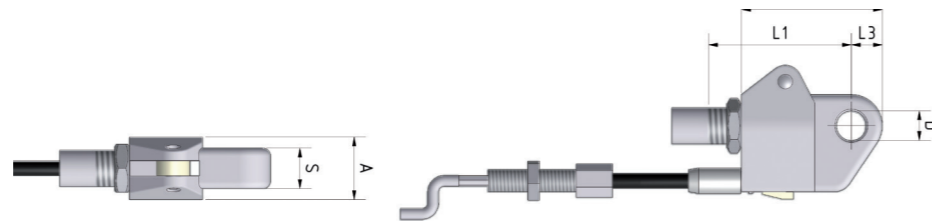

Type	Thread	L1	L2	L3	A	D	S
BD 35-10	M 10 x 1	40 mm	38.5 mm	8.5 mm	17 mm	8.1 mm	11 mm

Additional part: Adapter for M6 thread can be ordered
 Bowden cables with Z hooks matching the Bowden cable release BD35 in the standard lengths: 500, 750, 1000, 1250 and 1500 mm.

Hydraulic release system HY for locking gas springs

HY 1 · 1 Release for 1 spring

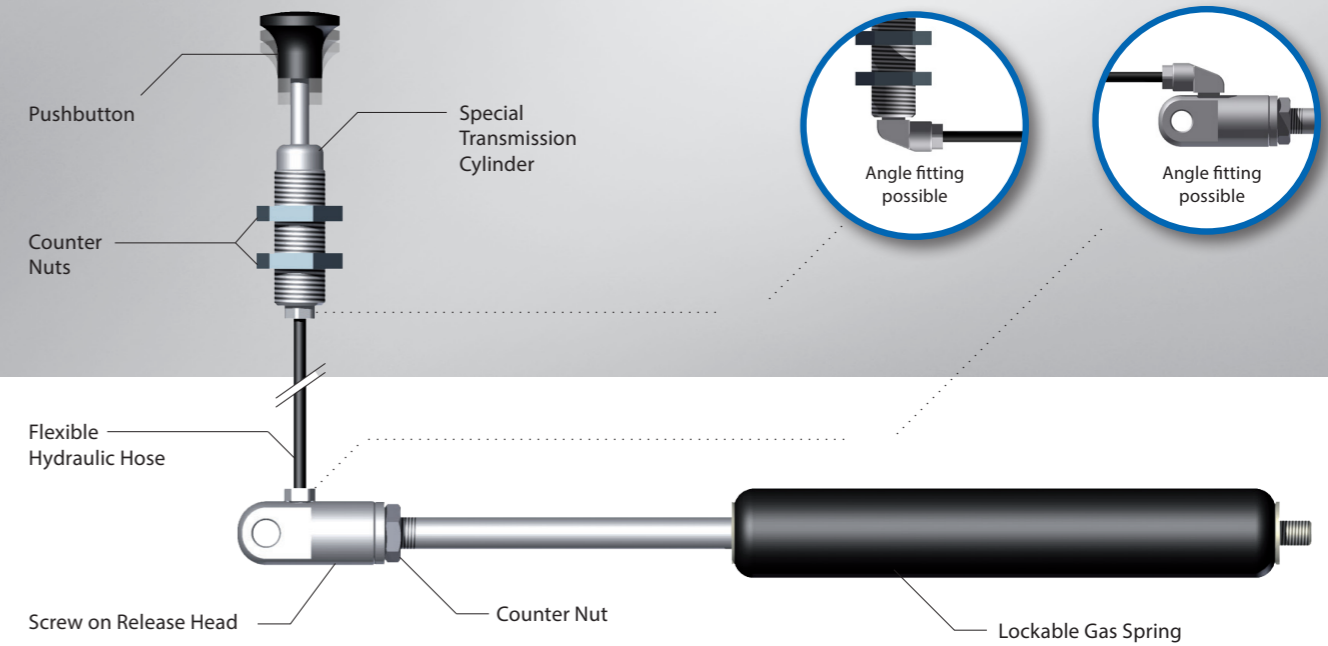

The Hahn Hydraulic Release System is especially made and adapted for your applications and requests.

You are getting a ready-to-install and maintenance-free system with a lot of advantages. Until now, the design and function of your latest designs and developments has been limited by cable controls and lever releases. The HY Release System gives more flexibility, just from the touch of a pushbutton.

Application Range:

- Furniture
- Massage Couches
- Hospital Beds
- Operation Panels
- Table Adjustments
- Safety Systems
- Handling Systems
- Medicine Devices
- Quick Adjustment of Seats for Heavy Plant Machinery, Cranes, Tractors etc.

HY 2 · 1 Release for 2 springs

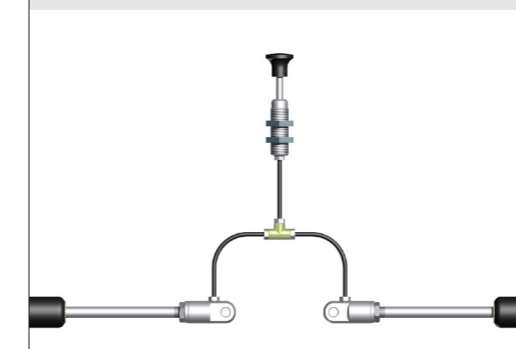

HY 3 · 2 Releases for 1 spring

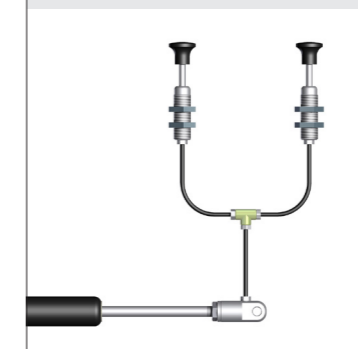

HY 4 · 2 Releases for 2 springs

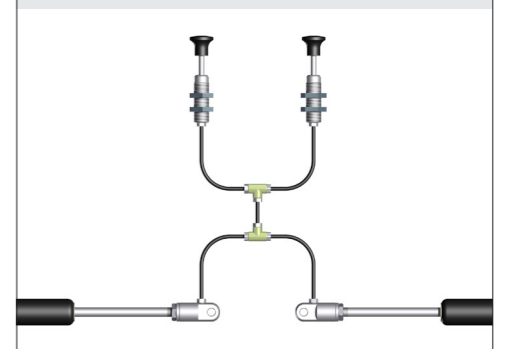



HAHN oil dampers are used for slowing down moving weights.

- Oil dampers are closed, maintenance-free hydraulic elements which are used for the smooth slowing of feed units, linear drive units, flaps, etc.

Fixed dampers work in extension, compression or in both directions and can hold up from 5N to 2500N. All fixed dampers are available in different sizes in steel and stainless steel AISI 303/304 and AISI 316L/316Ti.

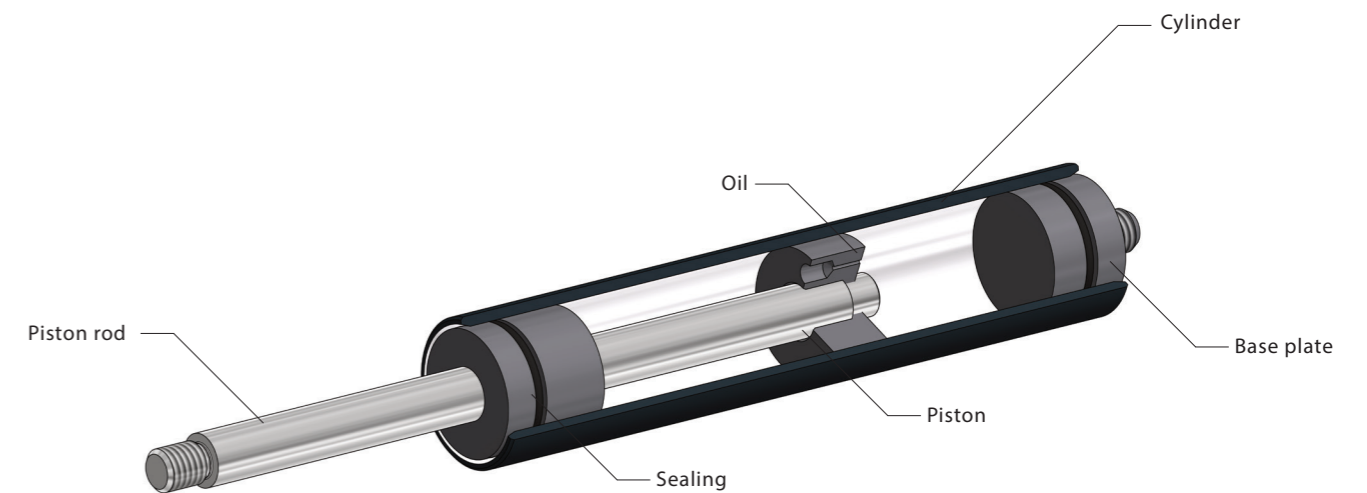

- The adjustable dampers (HB dampers) can be used on both sides or on one side. The ready-to-install and closed Systems provide a constant feed rate and are adjustable. Decisive here is the setting segment on the piston, which makes adjustment more easy.

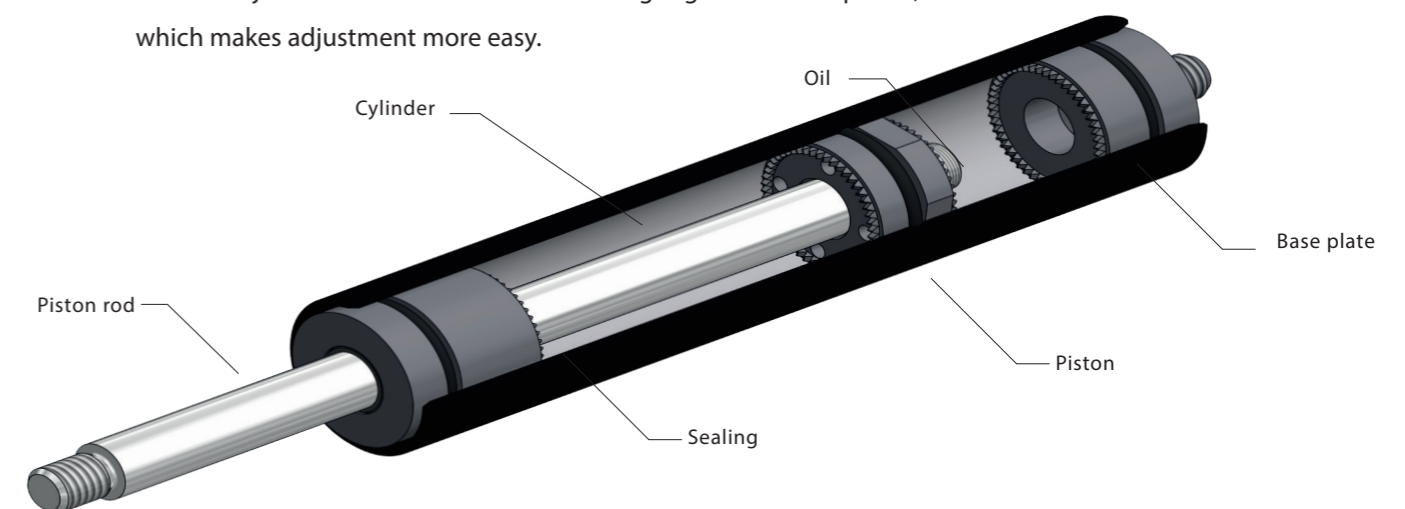

Oil dampers

The advantage of HAHN oil dampers is that the damping force as well as the compression and extension speed can be adjusted according to your requirements.



Standard product range

Type	Ø Rod	Ø Cylinder	Stroke	Standard length	Damping force	Damping
D 04-12	4 mm	12 mm	10 - 200 mm	2 x stroke + 32	5 - 100 N	comp./ext./both-way
D 06-19	6 mm	19 mm	20 - 300 mm	2 x stroke + 35	40 - 400 N	comp./ext./both-way
D 08-23	8 mm	23 mm	40 - 500 mm	2 x stroke + 40	50 - 800 N	comp./ext./both-way
D 10-28	10 mm	28 mm	40 - 500 mm	2 x stroke + 45	120 - 1200 N	comp./ext./both-way
D 14-40	14 mm	40 mm	50 - 600 mm	2 x stroke + 60	400 - 2500 N	comp./ext./both-way

Thread rod	Thread cylinder	Extras	Steel	AISI 303/304	AISI 316L/316Ti
M 3.5	M 3.5	-	•	-	o. r.
M 5	M 5	6, 7	•	•	•
M 8	M 8	6, 7	•	•	o. r.
M 8	M 8	6, 7	•	•	o. r.
M 10	M 10	1, 6, 7	•	•	•

Double-stroke spring

The special strength of HAHN Gasfedern is the solution of customer-specific tasks, for which we also develop unusual springs and products. The patent-protected double-stroke spring is an example for this.

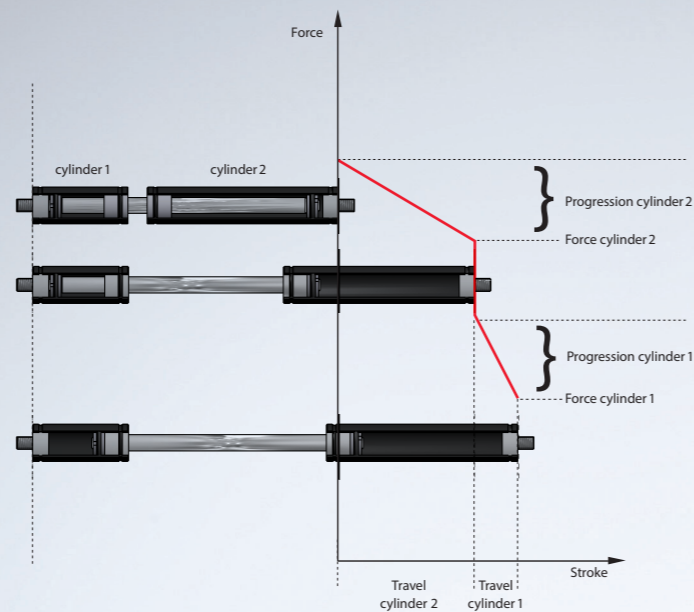
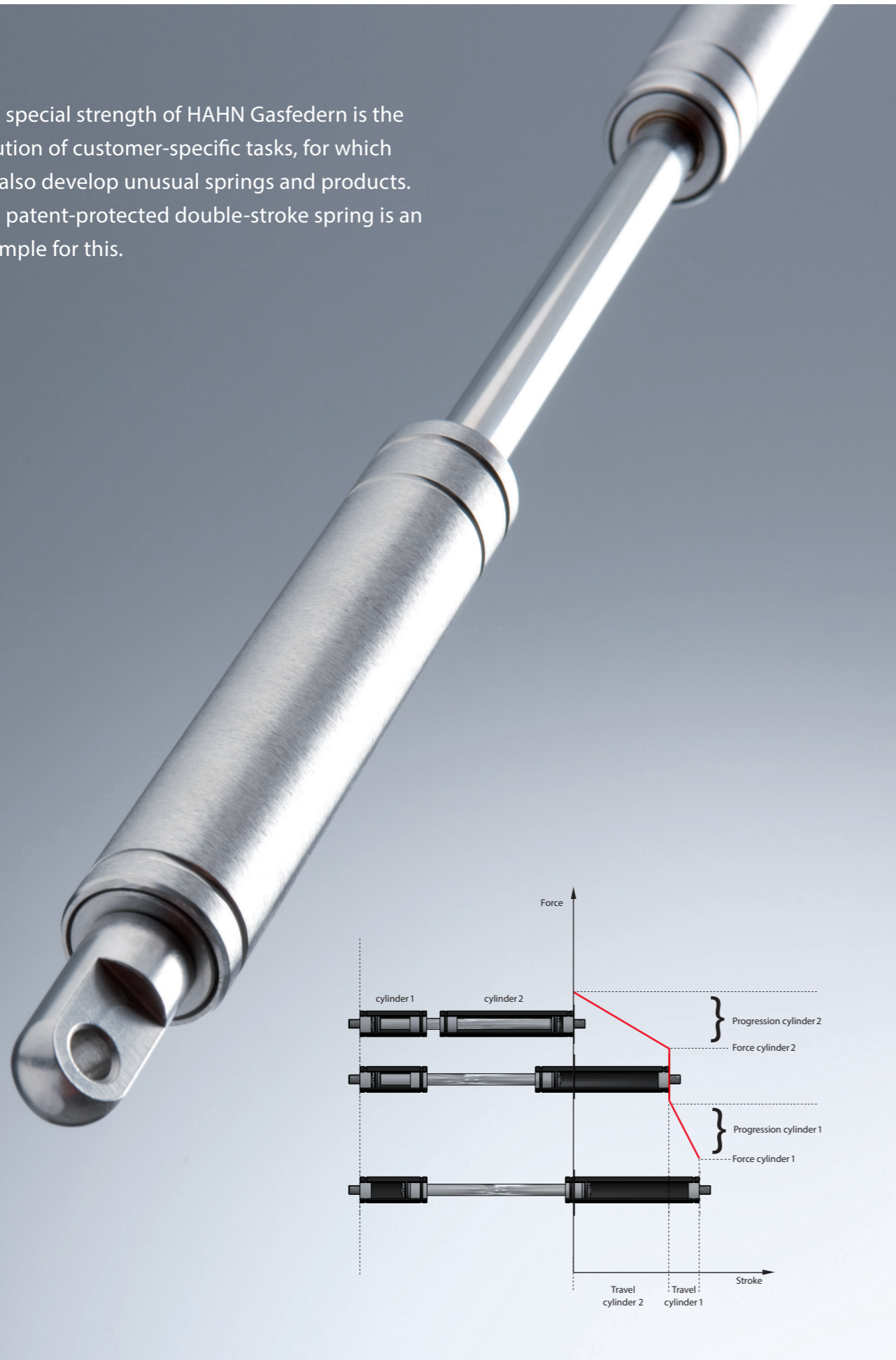

- ▶ HAHN Gasfedern developed special double-stroke springs for heavy flaps with a large opening angle, which are characterised by a low starting and a high ultimate force. These springs have two pressure cylinders that can be filled differently and thus are able to cover two force ranges. The compression of the piston rod generates a bent characteristic curve, which can be better adjusted to the force progression of the flap.

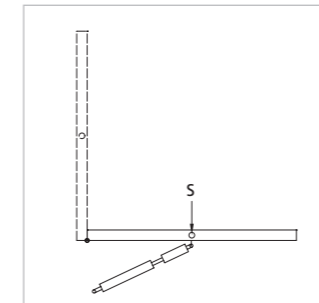

In this position, the point of gravity S is furthest away from the pivot point. The strongest force is required for opening the flap. Both strokes are compressed. The cylinder with the stronger force opens it.

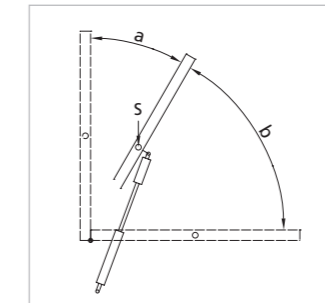

In this position, the point of gravity S moves closer to the pivot point. A weaker spring force is required. Stroke 1 is extended in this position. The spring part 2 with the weaker force now becomes effective.

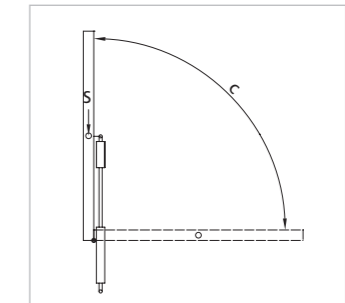

In this position, the point of gravity S is close to or directly on the pivot point. A weak spring force is required. Both strokes are fully extended.

Double-stroke springs are specially designed for the application you require.

The force ranges are exactly attuned to each other and adapted to the required kinematics. HAHN double-stroke springs are available in steel, in AISI 303/304 and AISI 316L/316Ti.

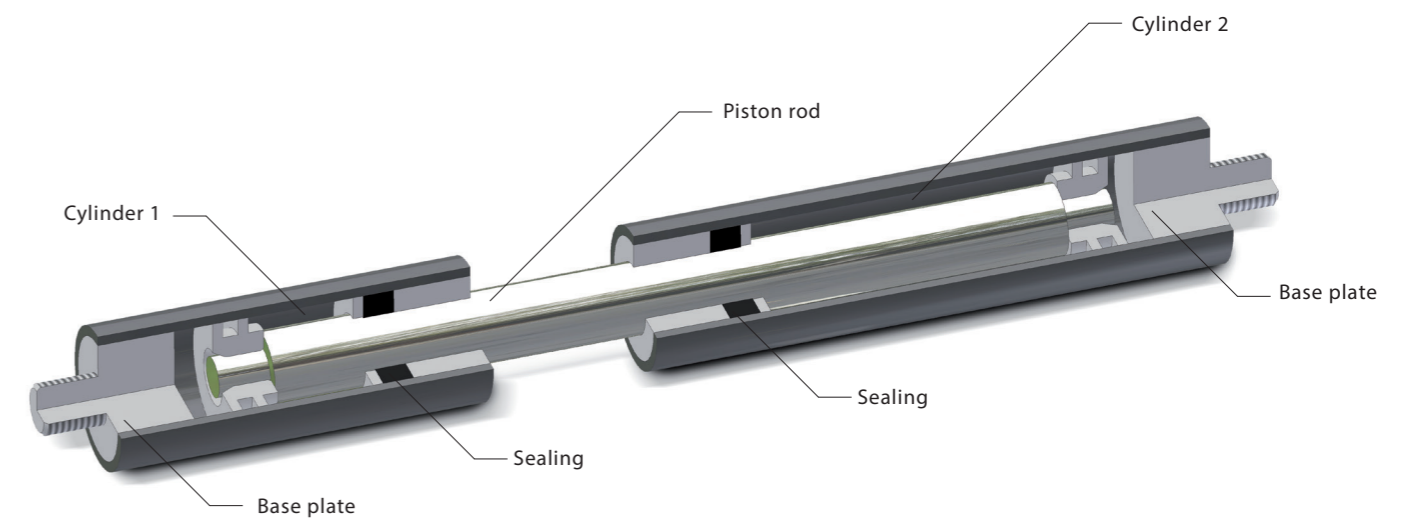

Sliding Door Damper (SDD)

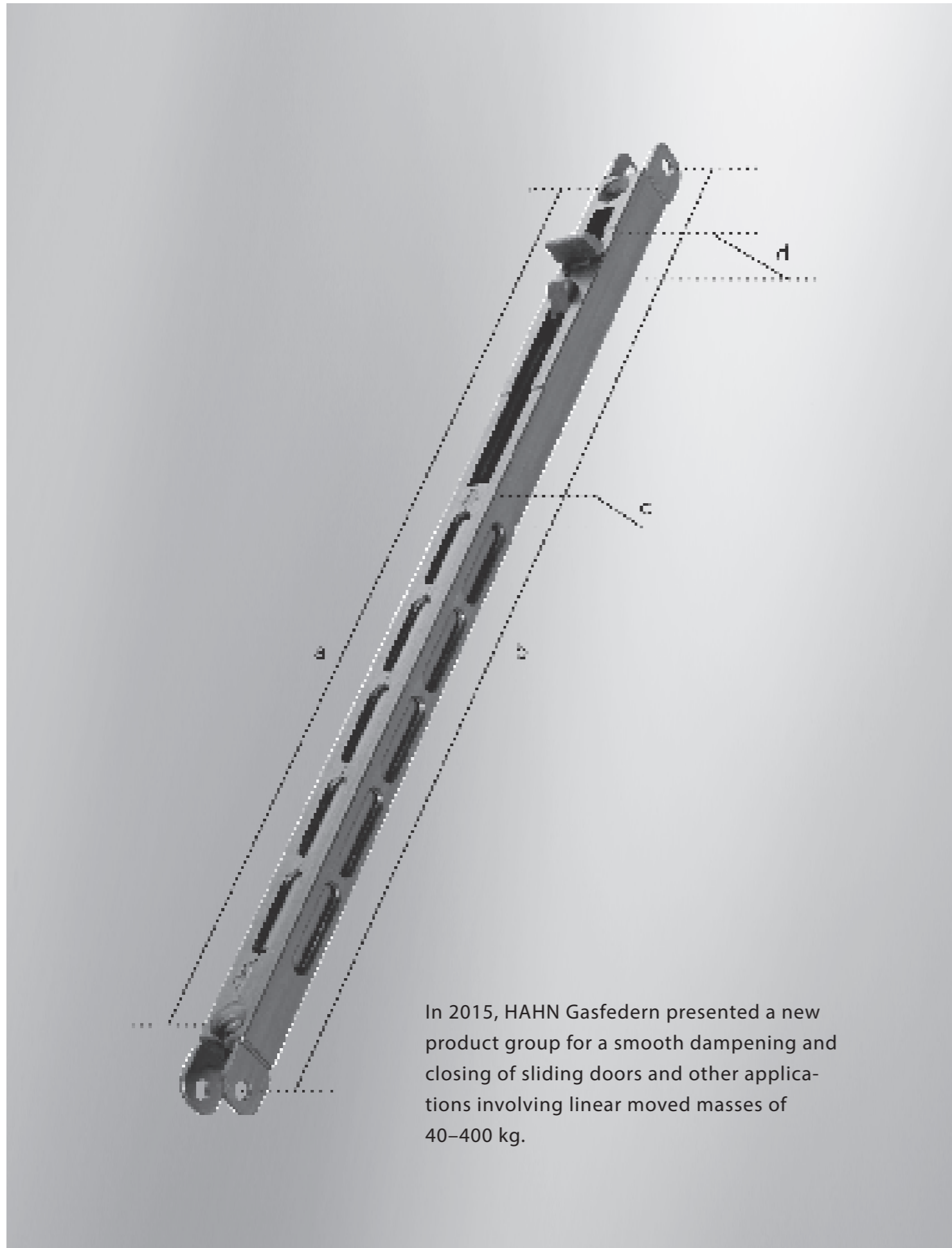

- The Sliding Door Gas Spring is our inexpensive entry-level product. Complementing the SD product family, the SDG provides a safe braking and prevents the braked masses from swinging back. The SDD is HAHN's advanced product for a safe, gentle and targeted braking and closing of sliding doors. With its Sliding Door Damper, HAHN Gasfedern is launching a real door-damper innovation into the market.

The Sliding Door Damper is a spring-damper element that combines the functions of two gas springs and one oil damper. Three functions are thus combined:

- cushioned docking
- degressive braking
- gentle closing

By the assist of additional assembly slots at the end of the housing, the installation becomes very easy and flexible.

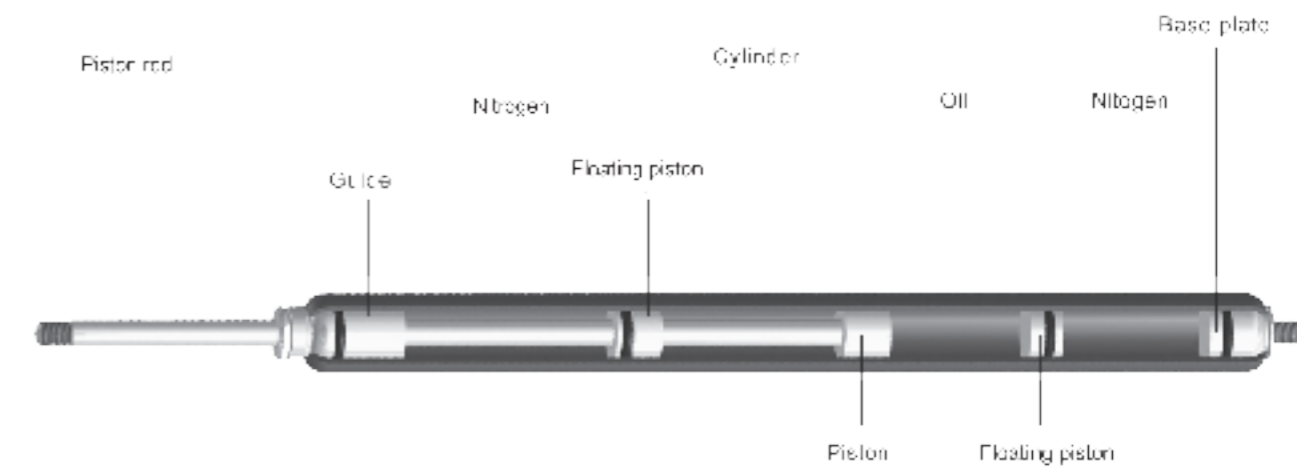

Type	Weight Range	Assembly Dimension
SDD 04-12	40-120 kg	a= 287 / b= 319 / c= 14,5 / d= 24,6 mm
SDG 06-15	100-200 kg	a= 287 / b= 319 / c= 14,5 / d= 24,6 mm
SDD 06-19	200-400 kg	a= 423 / b= 463 / c= 24 / d= 32,1 mm
SDG 04-12	20-80 kg	a= 287 / b= 319 / c= 14,5 / d= 24,6 mm
SDG 04-12 VA	40-80 kg	a= 287 / b= 319 / c= 14,5 / d= 24,6 mm
SDD 08-23	> 400kg	on request

Gas springs with ballpoint pen principle



The Gas springs with ballpoint pen principle are used wherever components have to be moved without a complex release system. They are used as a supporting opening and holding device in the furniture industry, in mechanical engineering, in medical technology and in many other areas of the industrial and private sector.

- ▣ The Springs with ballpoint pen principle are hydropneumatic, self-contained and maintenance-free adjustment elements. They are filled with compressed gas (nitrogen) which provides the spring tension. The spring tension results from the internal pressure in the cylinder, which is generated by the filling medium nitrogen. In the case of gas springs, this pressure is applied to the cross-sectional surface of the piston rod. The piston rod is always extended when no load is applied. By pushing in the piston rod, the volume in the cylinder is reduced and the gas is compressed. This results in an increase of the gas spring force (progression) depending on the diameter of the piston rod and the volume of the cylinder.

On addition, the gas spring with ballpoint pen principle can be mechanically locked in the retracted position. Similar to the ballpoint pen principle, the locking mechanism can be released by lightly pressing it in, whereupon the gas spring extends automatically. A large number of suitable connections and fittings ensure that the gas spring is optimally attached to your application.

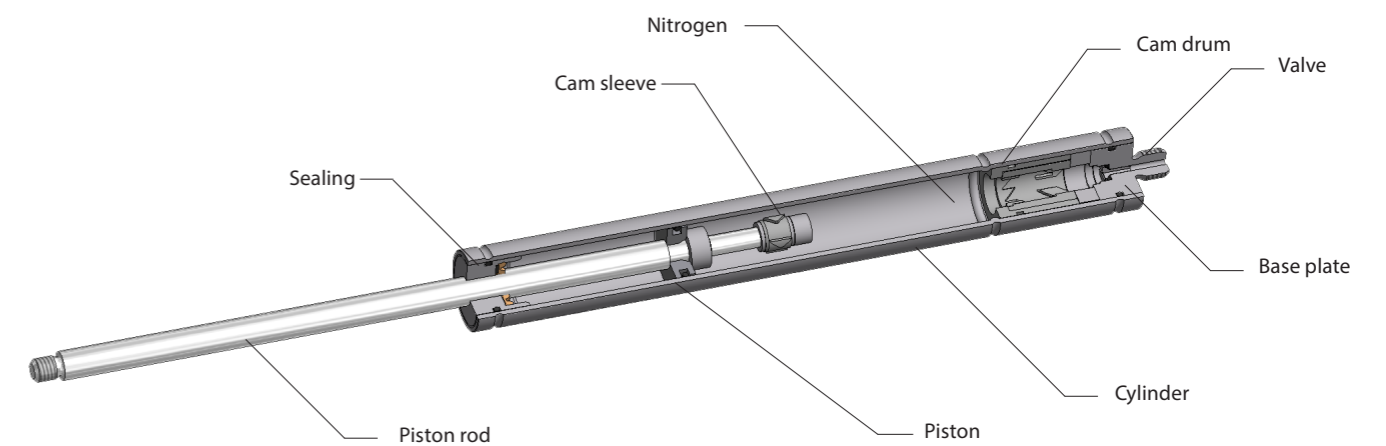

Fittings

With a broad range of fittings, brackets and special accessories, the application options for HAHN gas springs can be combined and extended in every possible way:

- ▢ Various fittings such as fork heads, hinged eyelets, hinged joints etc. are suitable for all mounting applications in combination with the matching brackets for the product. Depending on the individual case, HAHN supplies a variety of different fittings so that customers can select the respectively best solutions from this intelligent modular system.

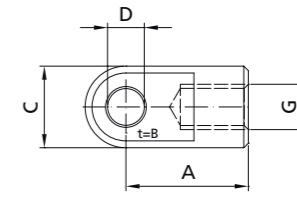
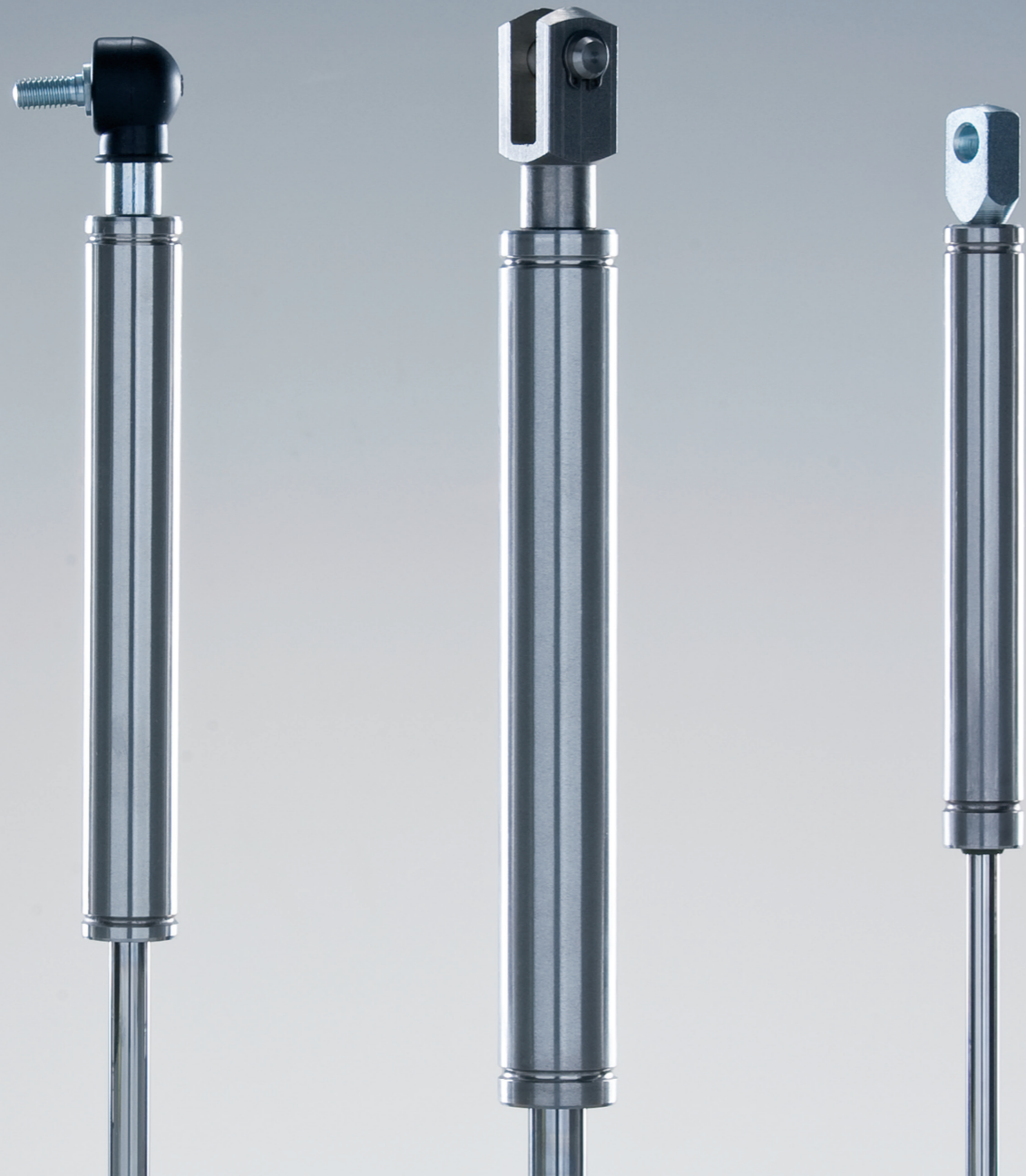

Eyelets

Type	Thread (G)	Installation length (A)	Thickness (B)	Width (C)	Cross hole Ø (D)	Steel	AISI 303/304	AISI 316L/316Ti	Plastic
AU 08	M 2	8 mm	2,5 mm	4 mm	2.1 mm	•	-	-	-
AU 11	M 3.5	11 mm	4 mm	8 mm	4.1 mm	•	-	-	-
AS 20	M 5	20 mm	3 mm	12 mm	6.1 mm	•	•	-	-
AU 16	M 5	16 mm	6 mm	10 mm	6.1 mm	•	•	•	-
AR 16	M 5	16 mm	10 mm	15 mm	8.1 mm	•	-	-	-
AX 16	M 5	16 mm	3 mm	10 mm	6,1 mm	•	-	-	-
AK 17	M 8	17 mm	14 mm	14 mm	8.1 mm	-	-	-	•
AK 21	M 8	21 mm	18 mm	18 mm	8.1 mm	-	-	-	•
AR 16	M 8	16 mm	10 mm	15 mm	8.1 mm	•	-	-	-
AR 19	M 8	19 mm	10 mm	15 mm	8.1 mm	•	-	-	-
AR 19	M 8	19 mm	10 mm	15 mm	10.1 mm	•	-	-	-
AR 27	M 8	27 mm	10 mm	15 mm	8.1 mm	•	-	-	-
AS 19	M 8	19 mm	8 mm	14 mm	8.1 mm	•	-	-	-
AS 24	M 8	24 mm	6 mm	14 mm	8.1 mm	•	-	-	-
AS 30	M 8	30 mm	5 mm	18 mm	8.1 mm	•	-	-	-
AU 19	M 8	19 mm	10 mm	14 mm	8.1 mm	•	•	•	-
AU 19	M 8	19 mm	10 mm	14 mm	6.1 mm	•	-	-	-
AX 24	M 8	24 mm	5 mm	14 mm	8,1 mm	•	-	-	-
AK 21	M 10	21 mm	18 mm	18 mm	8.1 mm	-	-	-	•
AS 27	M 10	27 mm	14 mm	18 mm	8.1 mm	•	-	-	-
AU 27	M 10	27 mm	10 mm	18 mm	8.1 mm	•	•	•	-
AU 27	M 10	27 mm	10 mm	18 mm	10.1 mm	•	•	•	-
AU 42	M 14 x 1.5	42 mm	14 mm	25 mm	14.1 mm	•	•	•	-

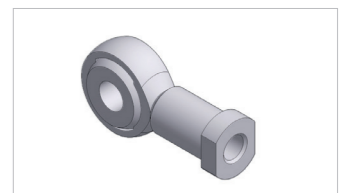
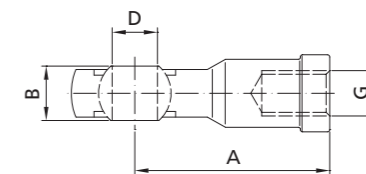

Hinged joints

Type	Thread (G)	Installation length (A)	Thickness (B)	Width	Cross hole Ø (D)	Steel	AISI 303/304	AISI 316L/316Ti	Plastic
AG 12	M 2	12.5 mm	4 mm	-	2 mm	-	-	-	•
AG 27	M 5	27 mm	8 mm	9 mm	5 mm	•	•	o. r.	-
AG 36	M 8	36 mm	12 mm	13 mm	8 mm	•	•	o. r.	-
AG 43	M 10	43 mm	14 mm	17 mm	10 mm	•	•	o. r.	-
AG 57	M 14 x 1.5	57 mm	19 mm	22 mm	14 mm	•	•	o. r.	-

Fittings

Ball joints and sockets

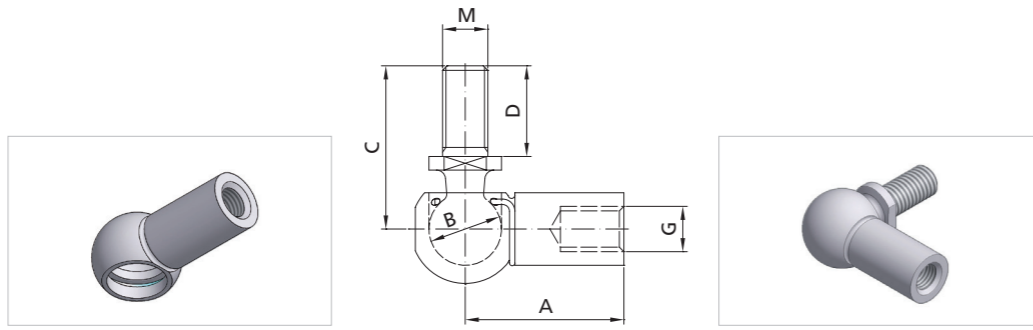

Type	Thread (G)	Installation length (A)	Socket diameter (B)	Bolt length (C)	Thread (MxD)	Steel	AISI 303/304	AISI 316L/316Ti
PF 12	M 2	12.5 mm	4 mm	12.5 mm	-	•	-	-
WG 12	M 2	12.5 mm	4 mm	12.5 mm	M 2 x 7.5	•	-	-
PX 18	M 3.5	18 mm	8 mm	-	-	•	-	-
WX 18	M 3.5	18 mm	8 mm	19 mm	M 4 x 10	•	-	-
PF 22	M 5	22 mm	8 mm	-	-	•	o. r.	o. r.
PX 22	M 5	22 mm	10 mm	-	-	•	-	-
WD 22	M 5	22 mm	10 mm	19 mm	M 8 x 12	•	-	-
WG 22	M 5	22 mm	8 mm	19 mm	M 5 x 10	•	•	•
WX 22	M 5	22 mm	10 mm	23 mm	M 8 x 12	•	•	-
WY 22	M 5	22 mm	10 mm	23 mm	M 6 x 12	•	-	-
PF 18	M 8	18 mm	10 mm	-	-	•	-	-
PF 30	M 8	30 mm	13 mm	-	-	•	o. r.	o. r.
WD 30	M 8	30 mm	13 mm	29 mm	M 8 x 16	•	-	-
WG 18	M 8	18 mm	10 mm	23 mm	M 8 x 12	•	•	-
WG 30	M 8	30 mm	13 mm	29 mm	M 8 x 16	•	•	•
WS 35	M 8	35 mm	16 mm	36 mm	M 10 x 20	•	-	-
WX 30	M 8	30 mm	13 mm	29 mm	M 10 x 16	•	-	-
PF 35	M 10	35 mm	16 mm	-	-	•	-	-
WG 35	M 10	35 mm	16 mm	36 mm	M 10 x 20	•	•	•
WG 45	M 14 x 1.5	45 mm	19 mm	48 mm	M 14 x 1,5 x 28	•	•	•

Axial joints

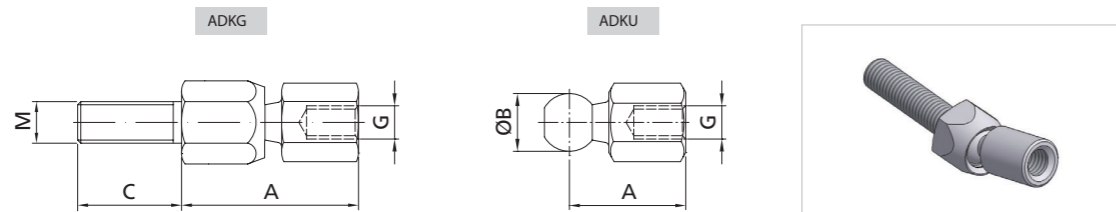

Type	Thread (G)	Installation length (A)	Ball diameter (B)	Bolt (MxC)	Steel	AISI 303/304	AISI 316L/316Ti
ADKG	M 5	28 mm	8 mm	M 8 x 35	•	-	-
ADKU	M 5	20 mm	8 mm	-	•	-	-
ADKG	M8	31 mm	10 mm	M 8 x 35	•	-	o. r.
ADKU	M 8	23 mm	10 mm	-	•	-	-
ADKG	M10	43 mm	14 mm	M 10 x 25	•	-	o. r.
ADKU	M 10	28 mm	14 mm	-	•	-	-
ADKG	M 14 x 1.5	56 mm	20 mm	M 14 x 1,5 x 40	•	-	-
ADKU	M 14 x 1.5	35 mm	20 mm	-	•	-	-

Base plate eyelet

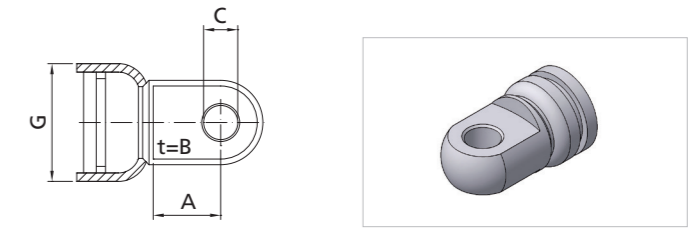

Type	For cylinder Ø (G)	Installation length (A)	Thickness (B)	Cross hole Ø (C)	Steel	AISI 303/304	AISI 316L/316Ti
AB 04	6 mm	4 mm	2.5 mm	2.1 mm	•	-	-
AB 07	10 mm	7 mm	4 mm	4.1 mm	•	-	-
AB 07	12 mm	7 mm	4 mm	4.1 mm	•	-	-
AB 09	15 mm	9 mm	6 mm	6.1 mm	•	-	-
AT 09	15 mm	9 mm	3 mm	6.1 mm	•	-	-
AB 11	19 mm	11 mm	10 mm	6.1 mm	•	-	-
AB 11	19 mm	11 mm	10 mm	8.1 mm	•	-	-
AB 11	23 mm	11 mm	10 mm	8.1 mm	•	-	-
AT 11	19 mm	11 mm	5 mm	8.1 mm	•	-	-
AB 11	23 mm	11 mm	10 mm	10.1 mm	•	-	-
AB 16	28 mm	16 mm	10 mm	8.1 mm	•	-	-
AB 16	28 mm	16 mm	10 mm	10.1 mm	•	-	-
AZ 20	40 mm	20 mm	14 mm	14.1 mm	•	•	-

Forks

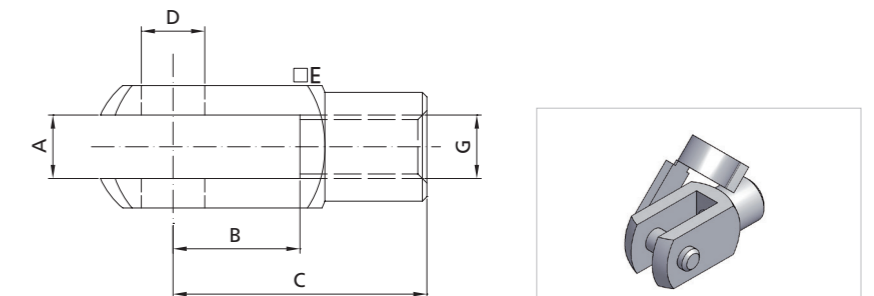

Type	Thread (G)	Size (A x B)	Installation length (C)	Width (E)	Bolt Ø (D)	Steel	AISI 303/304	AISI 316L/316Ti
GA16	M 3.5	4 x 8 mm	16 mm	8 mm	4 mm	•	-	-
GG 16*	M 3.5	4 x 8 mm	16 mm	8 mm	4 mm	•	-	-
GA 20	M 5	5 x 10 mm	20 mm	10 mm	5 mm	•	•	-
GG 20*	M 5	5 x 10 mm	20 mm	10 mm	5 mm	•	•	•
GA 32	M 8	8 x 16 mm	32 mm	16 mm	8 mm	•	•	-
GG 32*	M 8	8 x 16 mm	32 mm	16 mm	8 mm	•	•	•
GS 40	M 8	10 x 20 mm	40 mm	20 mm	10 mm	•	-	-
GA 40	M 10	10 x 20 mm	40 mm	20 mm	10 mm	•	•	-
GG 40*	M 10	10 x 20 mm	40 mm	20 mm	10 mm	•	•	•
GS 32	M 10	8 x 16 mm	32 mm	16 mm	8 mm	•	-	-
GX 32	M 10 x 1	8 x 16 mm	32 mm	16 mm	8 mm	•	-	-
GA 56	M 14 x 1.5	14 x 28 mm	56 mm	27 mm	14 mm	•	•	-
GG 56*	M 14 x 1.5	14 x 28 mm	56 mm	27 mm	14 mm	•	•	•
GA 80	M 20	20 x 40 mm	80 mm	40 mm	20 mm	•	-	-
GA 99	M 24	25 x 50 mm	99 mm	50 mm	25 mm	•	-	-

* Fork joint steel with ES-bolts, AISI 303/304 with Ben bolts, AISI 316L/316Ti with eyebolts.

Brackets

Depending on the size and material of your product, the fitting possibilities can also vary. HAHN Gasfedern therefore offers a wide range of matching brackets.

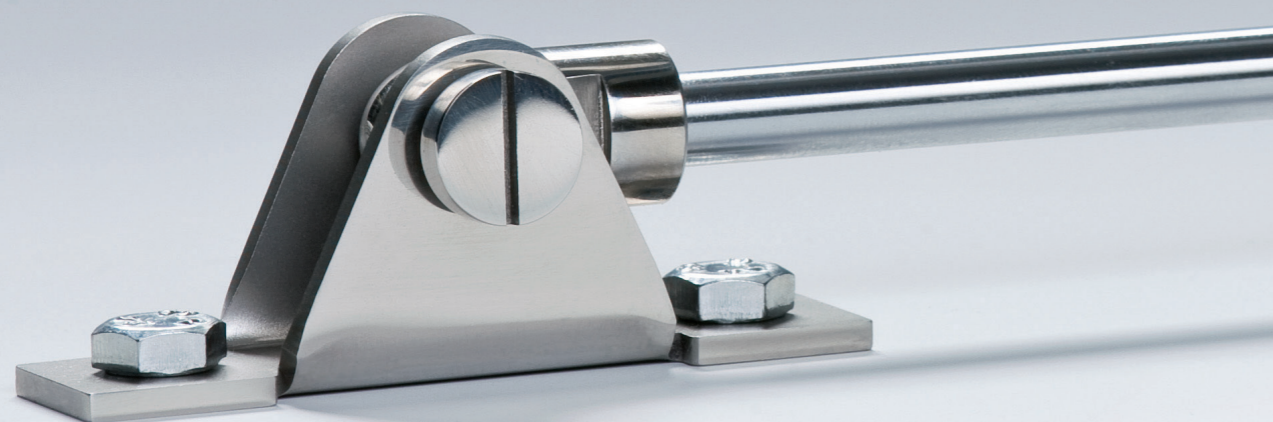

Brackets

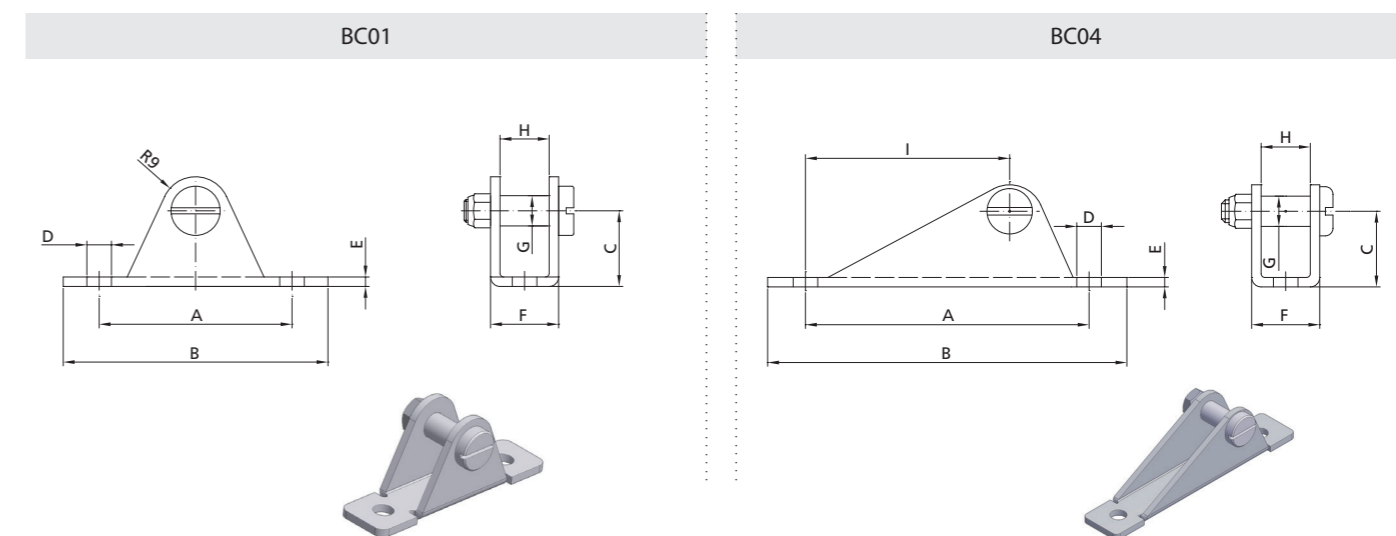

Bearing shoe

Type	A	B	C	D	E	F	G	H	I	Stability	Steel	AISI 316L/Ti
BC01	51 mm	70 mm	20 mm	6.5 mm	2.5 mm	18 mm	8 mm	13 mm	-	1800 N	•	•
BC04	75 mm	95 mm	20 mm	6.5 mm	2.5 mm	18 mm	8 mm	13 mm	54 mm	1800 N	•	•

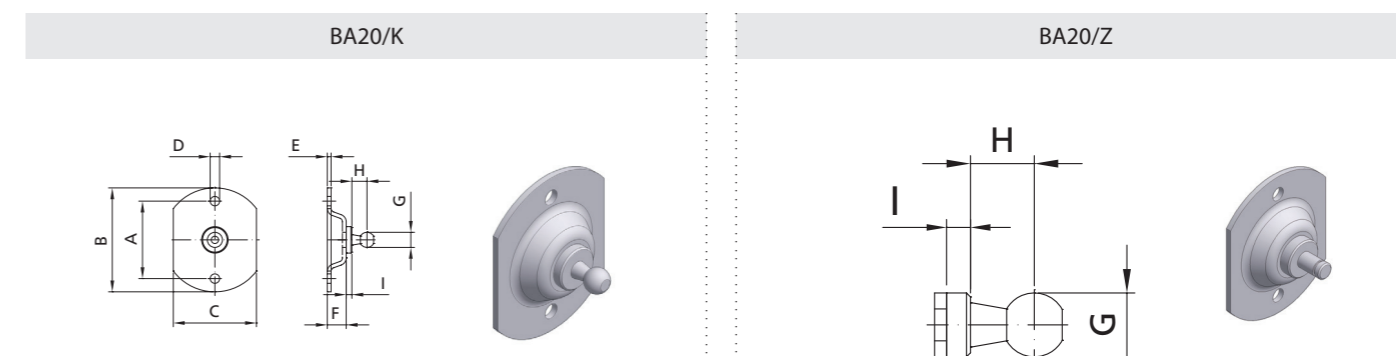

Round bracket

Type	A	B	C	D	E	F	G	H	I	Stability	Steel	AISI 316L/Ti
BA20/K08	41 mm	55 mm	44 mm	5.3 mm	2 mm	10 mm	8 mm	8 mm	3 mm	500 N	•	•
BA20/K10	41 mm	55 mm	44 mm	5.3 mm	2 mm	10 mm	10 mm	9 mm	3 mm	800 N	•	•
BA20/K13	41 mm	55 mm	44 mm	5.3 mm	2 mm	10 mm	13 mm	9.5 mm	3 mm	1200 N	•	•
BA20/Z06	41 mm	55 mm	44 mm	5.3 mm	2 mm	10 mm	6 mm	7 mm	4 mm	500 N	•	•
BA20/Z08	41 mm	55 mm	44 mm	5.3 mm	2 mm	10 mm	8 mm	11 mm	5 mm	1200 N	•	•

Brackets

For optimum use and perfect force transmission, HAHN Gasfedern offers a wide range of fittings and brackets. The displayed examples only are a small excerpt from our product range. If required, we can also develop a tailor-made solution for you.

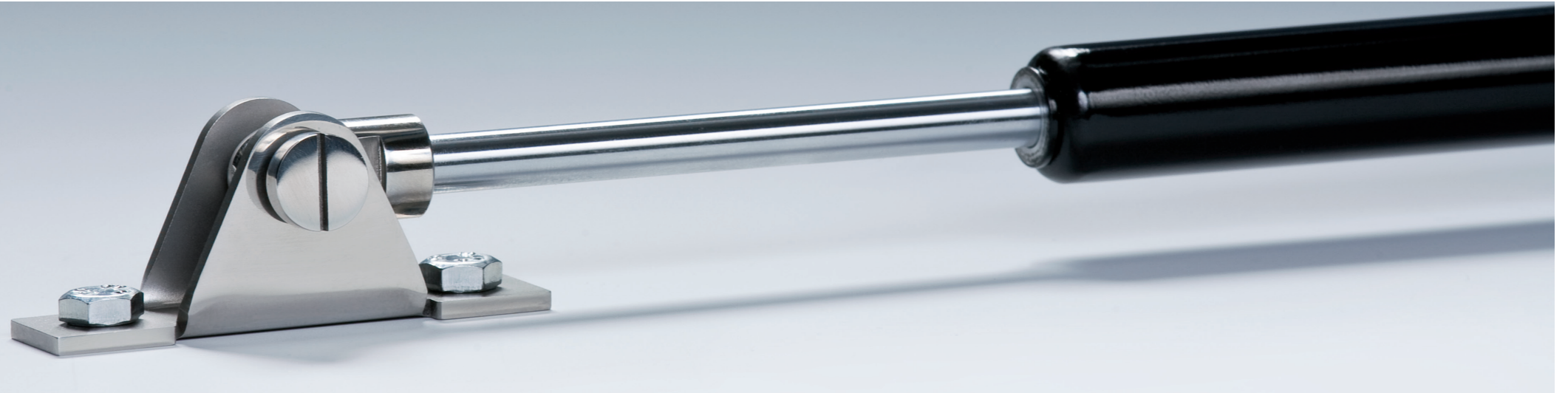

BA01/K

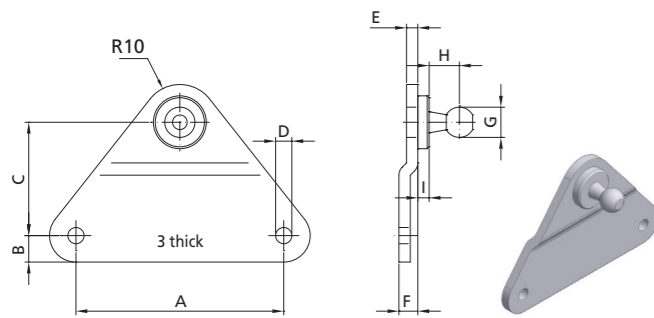

BA01/Z

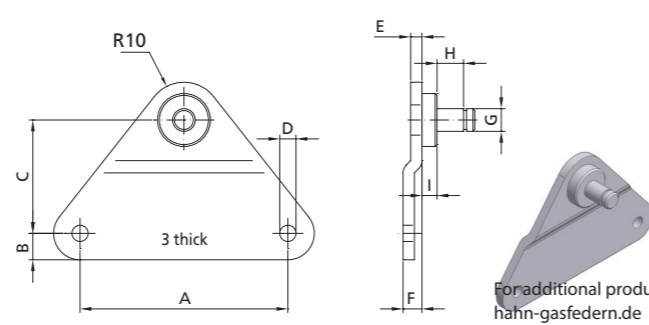

For additional product details, see Internet: www.hahn-gasfedern.de

BA30/K



BA30/Z

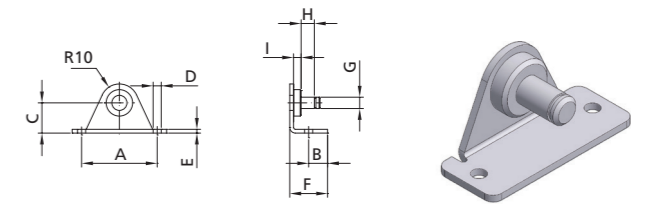

BB01/K

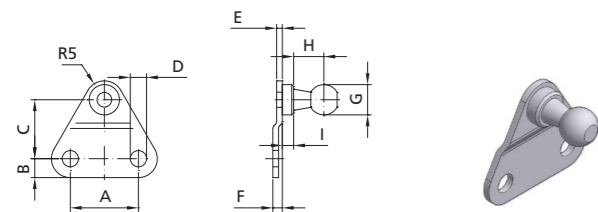

BB01/Z

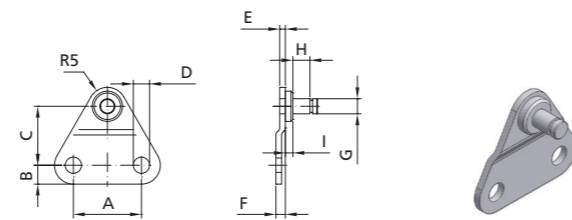

BB20/K

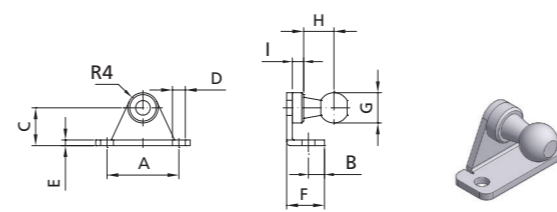

BB20/Z

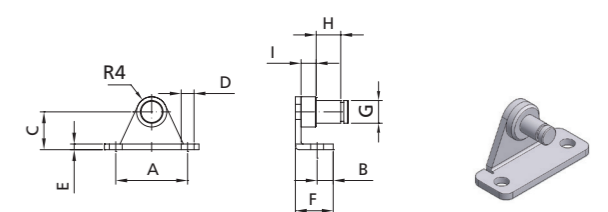

Side bracket

Type	A	B	C	D	E	F	G	H	I	Stability	Steel	AISI 316L/Ti
BB01/K08	18 mm	5 mm	15.5 mm	4.3 mm	1.5 mm	2.5 mm	8 mm	8 mm	3 mm	180 N	•	•
BB01/Z04	18 mm	5 mm	15.5 mm	4.3 mm	1.5 mm	2.5 mm	4 mm	4.5 mm	2 mm	180 N	•	•
BB01/Z06	18 mm	5 mm	15.5 mm	4.3 mm	1.5 mm	2.5 mm	6 mm	6.5 mm	4 mm	180 N	•	•
BA01/K08	55 mm	7 mm	30 mm	5.3 mm	3 mm	5 mm	8 mm	8 mm	3 mm	500 N	•	•
BA01/K10	55 mm	7 mm	30 mm	5.3 mm	3 mm	5 mm	10 mm	8 mm	3 mm	800 N	•	•
BA01/K13	55 mm	7 mm	30 mm	5.3 mm	3 mm	5 mm	13 mm	9.5 mm	3 mm	1200 N	•	•
BA01/Z06	55 mm	7 mm	30 mm	5.3 mm	3 mm	5 mm	6 mm	7 mm	4 mm	500 N	•	•
BA01/Z08	55 mm	7 mm	30 mm	5.3 mm	3 mm	5 mm	8 mm	11 mm	5 mm	1200 N	•	•

Angular bracket

Type	A	B	C	D	E	F	G	H	I	Stability	Steel	AISI 316L/Ti
BB20/K08	19 mm	4.25 mm	10 mm	3.4 mm	1.5 mm	10 mm	8 mm	8 mm	3 mm	180 N	•	•
BB20/Z04	19 mm	4.25 mm	10 mm	3.4 mm	1.5 mm	10 mm	4 mm	4.5 mm	2 mm	180 N	•	•
BB20/Z06	19 mm	4.25 mm	10 mm	3.4 mm	1.5 mm	10 mm	6 mm	7 mm	4 mm	180 N	•	•
BA30/K08	40 mm	10 mm	16 mm	5.3 mm	2 mm	20 mm	8 mm	8 mm	3 mm	500 N	•	•
BA30/K10	40 mm	10 mm	16 mm	5.3 mm	2 mm	20 mm	10 mm	9 mm	3 mm	800 N	•	•
BA30/K13	40 mm	10 mm	16 mm	5.3 mm	2 mm	20 mm	13 mm	9.5 mm	3 mm	1200 N	•	•
BA30/Z06	40 mm	10 mm	16 mm	5.3 mm	2 mm	20 mm	6 mm	7 mm	4 mm	500 N	•	•
BA30/Z08	40 mm	10 mm	16 mm	5.3 mm	2 mm	20 mm	8 mm	11 mm	5 mm	1200 N	•	•

With special protection tubes, locking devices and other extras, HAHN gas springs can also be used in difficult environments. For even more extreme conditions, our specialists and technicians develop intelligent solutions that meet virtually every requirement.

1 – Wiper ring

The wiper ring prevents foreign matter from entering into the gas springs.

2 – Radial valve

Via the radial valve, the force of the gas spring can be adjusted when it is built in. Radial valves need to be considered when calculating the length of the gas spring (GL).

3 – Piston rod sealing

Prevents humidity, cleaning agents and other foreign matters from entering into the release system of the locking gas springs

4 – Grease chamber

Permanent lubrication of the piston rod; thus lower friction forces and installation of the gas spring independent from the position. When designing the gas spring, a reduction of the usable stroke needs to be considered.

5 – Valve

The valve allows the force of the gas spring to be adjusted. In the gas spring, it is located at the threaded pin of the base plate; in the tension spring, it is designed as a valve section on the piston rod.

6 – Protection tube

Protects the piston rod from mechanical damage. Reduces the risk of bending for long strokes

7 – Floating piston

Oil-hydraulic damping along the entire stroke, independent of the installation position

8 – Locking device

Mechanical locking for extended piston rod. The locking device needs to be considered when calculating the length of the gas spring (GL).

9 – Short release

The release way for locking gas springs is 0.1 - 0.2 mm (standard 2 - 5 mm).

10 – HAHN Reducer

The „HAHN Reducer“ was made for the safe and comfortable reducing of nitrogen for gas springs with a valve. The „HAHN Reducer“ is screwed on the valve at the bottom-plate of the gas-spring . By pressing the grip, the valve opens and the gas can escape. The pressure must not be permanently released, but in short intervals.

11 – HAHN Clean Cap

The HAHN Clean Cap is an additional protection for preventing the piston rod against influences from the environment. It can be added even after the gas spring is already in use. The cap is made out of an aluminium slice, a NBR-Wiper ring and a cap of PVC, which is responsible for keeping the slice and the ring in a straight position when it is pulled.

B3 – Sealing system

For gas springs with high forces and increased wear, e.g. use in building machines. Allows an installation of the gas spring independent of the position. When designing the gas spring, a reduction of the usable stroke needs to be considered.

NT – Low-temperature design

For use of gas springs at an ambient temperature of up to - 40°C. Allows installation of the gas spring independent of the position. When designing the gas spring, a reduction of the usable stroke needs to be considered.

HT – High-temperature design

For use of gas springs at an ambient temperature of up to 200°C. Allows installation of the gas spring independent of the position. When designing the gas spring, a reduction of the usable stroke needs to be considered.

RK – Friction element

Increases the friction force for gas springs for the secure positioning of windows, skylights, etc.

Must be observed prior to mounting, construction or storage!

I. Safety

- If gas pressure springs, gas tension springs or dampers are used in situations where a failure of the product can lead to personal injury and/or property damage, additional safety elements must be installed. The installation/removal of HAHN products must always be carried out in compliance with the accident prevention regulations!
- HAHN products are not safety components! Gas pressure springs, gas tension springs and dampers are maintenance-free products that are subject to wear and tear and must therefore be regularly tested for their function depending on the load and application. In order to increase service life and fatigue strength, the products must in particular be protected against corrosion. Most of our products are also produced in stainless steel (V2A and V4A). Small quantities of hydraulic oil may leak from the products; it must not come into contact with foodstuffs or ground water. In addition to the standard hydraulic oil, alternative types of oil can be used for other areas such as the food industry.
- Gas springs are filled with technically pure nitrogen. Technically pure nitrogen does not burn, does not explode and is not harmful to the environment. Gas springs are under high pressure and may only be opened according to instructions (see point IV. Storage/Disposal).
- HAHN products must not be overheated or exposed to open fire.
- Before disassembly or other handling, the products must be checked for visible damage such as deformed connecting parts or a bent piston rod. In case of visible damage, the pressure must be released before disassembly.

II. Installation/Function

- Gas pressure springs and dampers should preferably be installed with the piston rod pointing downwards, tension springs with the piston rod pointing upwards. For alternative installation solutions, please contact our technical sales department.
- In order not to impair the service life, gas springs must not be subjected to canting, bending or transverse forces; only axial loads are permissible. Depending on the force, stroke, series and overall length of our products, there may be a risk of kinking. The piston rod must be protected against impacts, scratches, dirt and paint. Depending on several factors such as installation situation/application, the model series, the stroke used, ambient conditions, a service life of more than 50,000 cycles is possible.
- A gas spring is subject to a technical loss of force over time and due to operation. This occurs even if the piston rod is not moved. The amount of force loss depends, among other things, on the type, size, gaskets used and application. Values of 5% within the first 12 months and 10% within 4 years are quite normal, but in individual cases they can be significantly higher.
- Screwed-on fittings such as eyes, angle joints, etc. must be completely screwed in and rest against the front. Loose connections must be completely screwed on before installation. If vibrations occur, the connections must be secured against loosening.
- Environmental conditions (dust, temperature fluctuations, humidity, etc.), aggressive media, incorrect installation or mechanical influences can lead to damage and affect the service life. To help you find the right solution, please contact our technical sales department.
- Gas pressure springs, gas tension springs and dampers may be used as end stops if the nominal force does not exceed +30% (no overstretching or compression of the product), i.e. the products may only be loaded with their nominal force +30% on compression or tension. Mechanical stops should be additionally attached, particularly at high forces, in order to prevent the product from being compressed or overstretched.
- Standard range of application for our gas springs and dampers: -20°C to +80°C. We offer solutions for a range from -40°C to +200°C.
- Gas tension springs are open systems, i.e. it must be avoided that dirt or other media get into the tension springs through the ventilation hole at the cylinder end.
- Lockable gas pressure springs have a through hole in the piston rod with a release pin. It must be avoided that foreign media such as dirt or cleaning agents penetrate the piston rod hole (protection is provided by an optional piston rod seal). Contamination can lead to corrosion in the piston rod and cause the release pin to get wedged. When installing a release system, make sure that the permissible release travel is adhered to.
- Some products in the HAHN Gasfedern range are fitted with a valve. As an option, further products can be equipped with a valve. A valve can be used to increase the force by refilling or reduce the force by draining. The instructions for the correct handling of the valve can be found on our homepage. (<https://www.hahn-gasfedern.de/de/service/serviceprodukte.html>)
- Filling of the products only with written permission of HAHN Gasfedern GmbH.
- Angle joints may be supplied with a safety catch. For safety reasons, this catch must be used when mounting the spring, to avoid injury.

- We use 3.5 mm threads for the G03-08 and G03-10 model ranges. This is not the standard setup. The outside diameter is smaller than indicated in the standard specifications. However, connectors using a standard 3.5 mm thread can be used without problem.

III. Tolerances/characteristics

- Maximum traverse speed for gas springs = 300 mm/s in installed condition.
- Length tolerance of the products = +/- 2 mm
- The damping force of adjustable dampers is increased or decreased by turning the piston rod in the end positions. The total length changes when the piston rod is turned.
- The tolerance for extension or tensile forces at 20° is generally: F1 nominal force ± 10%, at least ± 3 Newton. The nominal force is measured statically when the stroke is extended (for tension springs when the stroke is retracted) 5 mm before the end of the stroke (standard). For further information, please contact our technical sales department.
- The indicated F1 force for gas pressure springs and gas tension springs is based on an ambient temperature of 20°C. This force is increased or decreased at a different ambient temperature. A temperature difference of 10°C results in a change of the F1 force by approx. 3-3.5%.
- When the ambient temperature changes, the properties of products with oil filling also change.

IV. Storage/Disposal

- Gas pressure springs and dampers should be stored with the piston rod pointing downwards, tension springs with the piston rod pointing upwards. If properly stored, no pressure losses are to be expected; however, the products should not be stored for more than 1 year (see II Installation/Function Point 3). Before the piston rod is moved for the first time, the film tubes must be removed. When the products are operated (retraction/extension of piston rod) for the first time after longer periods of non-use, a sticking effect can occur (breakaway torque and slip-stick effect), which means that higher forces are required to move the product. This effect levels out after one or two cycles. Storage of gas springs should be carried out according to the FIFO principle (First In First Out). After a longer storage period, a slight oil wetting may occur on the piston rod side. This is system-related and has no effect on the functionality.
- Disposal: Dampers, gas pressure and gas tension springs are under pressure. They must not be opened or heated. The products may only be opened according to the instructions of HAHN Gasfedern GmbH. You will find the disposal regulations/instructions for opening the products on our homepage. (<https://www.hahn-gasfedern.de/de/download.html>). We are happy to take back our products and dispose of them for you.

V. Warranty

- Warranty claims expire one year after the date of manufacture of the products. The warranty is void if the date of manufacture on the labels of our products is illegible or has been removed. Defects in the quality of the products must be reported immediately. Returns will only be processed with a fully completed return note.
- Warranty is excluded for any installation suggestions/drawings for the installation of gas pressure springs, gas tension springs and dampers. Product installation must be carried out with utmost care, since friction values or accelerations cannot or can only roughly be considered in the theoretical suggestion. In order to calculate as precisely as possible your desired application, we ask you to fill in our forms for the calculation of gas pressure springs, tension springs and/or dampers as accurately and completely as possible. The forms can be found on our homepage (www.hahn-gasfedern.de/de/download.html).

VI. General information

- Our products are manufactured to order. A cancellation or subsequent changes as well as an exchange or return of the product is therefore excluded.
- If dampers, gas pressure springs and gas tension springs are sent in for testing, the consent to open the product is granted and the right of ownership expires. The products sent in will be disposed of 4 weeks after notification of the test results.
- In principle, the following applies: For unjustified returns we reserve the right to charge a flat-rate fee or the actual costs for processing and disposal.
- In case of returns, the buyer bears the shipping costs, returns by cash on delivery are not accepted.

Failure to observe our technical regulations will void any warranty.

Sales partners

We have a close world-wide network of sales partners, who can help you solve your tasks directly on location.

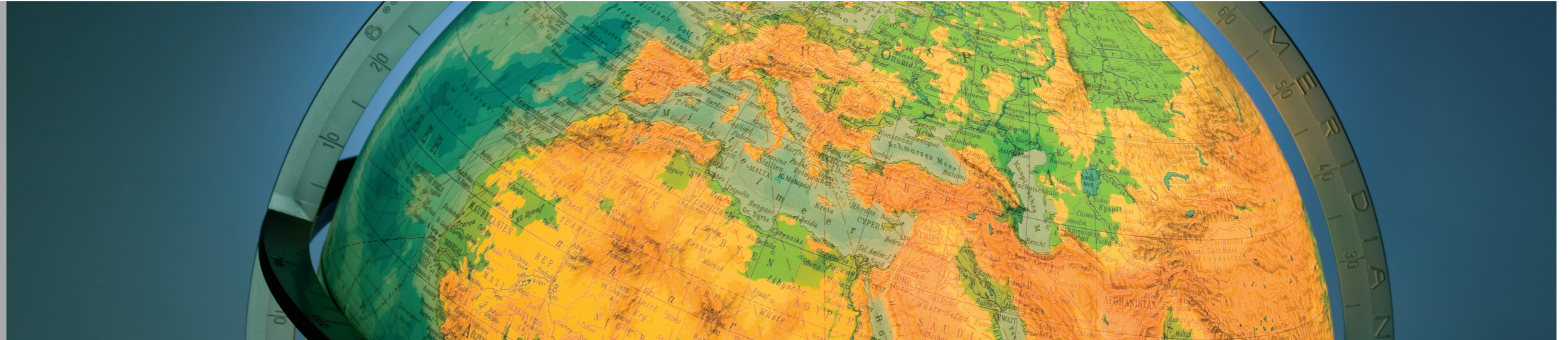

Austria

Rothmund und Konhäuser KG
Laxenburgerstrasse 240-242
1239 Wien
Phone: +43 1616 2611
Fax: +43 1616 0343
office.industrie@roko.at
www.roko.at
Contact: Mr. Chris Messler

China

Shanghai Qianhe M&E Equipment Co.,Ltd
No.398-3-2F, Shengang Road,Shanghai
China 201612
Phone +86 21 5413 3099
Fax:+86 21 5413 1927
sales@shqhdq.com
www.shqhdq.com
Contact: Mr. Jeffrey Chen

Czech Republic/Slovakia

ECKOLD&VAVROUCH, spol. s r.o.
Jilemnického 8
614 00 Brno
Phone: + 420 5452 1158 2
Fax: +420 5452 1158 2
eckold@volny.cz
www.eckold.cz
Contact: Mr. Martin Vavrouch

Denmark

RGE Europe
Lysagervej 8
2920 Charlottenlund
Phone: +45 3966 3030
Fax: +45 3966 2930
mab@rge-europe.com
www.rgeeurope.com
Contact: Mrs. Maj-Britt Brocelius

Finland

MOVETEC OY
Suokalliontie 9
01740 VANTAA
Phone: +358 9525 9230
Fax: +358 9525 9233 3
pekka.jokinen@movetec.fi
www.movetec.fi
Contact: Mr. Pekka Jokinen

France

ECKO TECH
6, allée des Carrières
Z.I. des Portes de la Forêt
77090 COLLEGIEN
Phone: +33 1643 0924 7
Fax: +33 1643 0819 2
info@eckotech.fr
www.eckotech.fr
Contact: Mr. Frédéric Delacourt

GCC States

Mechatronics Industrial Equipment
P.O. Box: 19104, Dubai - U.A.E.
Phone.: +97 1426 7431 1
Fax: +97 1426 7431 2
mechtron@emirates.net.ae
www.mechatronics.ae
Contact: Mr. Stanley C.J. Daniel

Germany

HAHN Gasfedern GmbH
Waldstraße 39-43
73773 Aichwald
Phone: +49 711 936 705-0
Fax: +49 711 936 705-40
info@hahn-gasfedern.de
www.hahn-gasfedern.de

Great Britain/Ireland

ECKOLD Ltd.
15 Lifford Way
Binley Industrial Estate
West Midlands CV32RN, Coventry
Phone: +44 2476 455580
Fax: +44 2476 456931
sales@eckold.co.uk
www.eckold.co.uk
Contact: Mr. Mark Watton

Hungary

Eurowind Kft.
Alba Industrial Zone
Zsálya street, nr. 5
8000 Székefehérvár
Phone: + 36 22 505 725
Fax: + 36 22 331 666
eurowind@eurowindgroup.com
www.eurowindgroup.com
Contact: Mr. Robert Nagy

India

A.C. AUTOMATION
301, Mukund House,
Commercial Complex,
Azadpur, Delhi - 110 033 India
Tel.: +91 1141 4727 15,
Mobile: +91 9873 9221 93
sales@acautomation.in
www.acautomation.in
Contact: Mr. Anoop Chopra

Israel

SystematITech Ltd.
Paz Hateomim center, Mishmar Hashiva
P.o.box 21125
61211 Tel-Aviv
Phone: +972 0396 0500 8
Fax: +972 0396 0500 4
sales@systematitech.com
www.systematitech.com
Contact: Mr. Natan Rom

Italy

Roberto Galdoni
Sales Manager Italy
Business Unit Industrial
T +49 261 8900 8133
M +39 348 3338080
rgaldoni@stabilus.com
www.hahn-gasfedern.de

Japan

ECKOLD Japan Co., Ltd.
ZIP: 274-0824
2-14-2, Maehara-Higashi,
Funabashi, Chiba-Pref.
Phone: +81 47 470 2400
Fax: +81 47 470 2402
tokita@eckold.co.jp
www.eckold.co.jp
Contact: Mr. Tomoyuki Tokita

Netherlands/Belgium/Luxemburg

Protempo B.V.
Postfach 21
6500 AA Nijmegen
Phone: +31 0243 7117 11
Fax: +31 0243 7117 00
info@protempo.eu
gasveren@protempo.eu
www.protempo.eu
Contact: Mr. Fons Jansen

Norway

A.C. LANDGRAFF AS
Postboks 14
Nesveien 13
1305 Haslum
Phone: +47 6752 6000
Fax: +47 6753 8812
landgraff@landgraff.no
www.landgraff.no
Contact: Mr. Morten Landgraff

Pakistan

Capricorn Trading
G-6, Ground Floor
Entrance „A“
10 Mules Mansions
Napier Mole Road
Keamari
Karachi - 75620
Phone: + 92 21 32862855 & 32862866
Mobile: + 92 334 3659001
capricorntrading@gmail.com
Contact: Zubin F. Mavalvala (Proprietor)

Poland

EA Kraków s.c.
32-050 Skawina
ul.Piłsudskiego 39 b
Phone: +48 12 276 07 70
Fax: +48 12 276 37 74
kf@ea.krakow.pl
www.ea.krakow.pl
Contact: Mr. Krzysztof Frączek

Romania

S.C. PARCON FREIWALD S.R.L
Str. Depozitelor nr. 22
540240 Tg - Mures
Phone: +40 265 253 088
Mobil: +40 730 960 530
nicula@parconfreiwald.ro
Contact: Mr. Marius Cristian Nicula

Russia

WIV Industrievertretungen
Lortzingring 30
61118 Bad Vilbel
Phone: +49 (0)6101 54 1328
Phone: +7 921 949 5156
wivwollbaum@yahoo.de
www.wollbaum.com
Contact: Mr. Arkadi Wollbaum
Аркадий Вольбаум

Southeast Asia

SERVO DYNAMICS Pte Ltd.
No. 10 Kaki Bukit Road 1
#01-30 KB Industrial Building
SINGAPORE 416175
Phone: +65 6844 0288 Ext. 72
Fax: +65 6844 0070
servodynamics@servo.com.sg
www.servo.com.sg
Contact: Mr. S.Y. Low

Spain/Portugal

DICTATOR ESPAÑOLA, S.A.
C/ Mogoda, 20-24 P.I. Can Salvatella
08210-Barber del Valles (Barcelona)
Phone: +34 9371 9131 4
Fax: +34 9371 8250 9
dictator@dictatorspain.com
Contact: Mr. Xavier Diago

Switzerland

Eckold AG
Rheinstrasse 8
7203 Trimmis
Phone: +41 8135 4125 0
Fax: +41 8135 4125 1
verkauf@eckold.ch
www.eckold.ch

USA

STABILUS
1201 Tulip Drive
Gastonia, NC 28052
Phone: +1 704 810 3609
info.us@stabilusindustryline.com
www.stabilus.com

Sweden

ARATRON AB
Smidesvägen 4-8
S-17141 Solna
Phone: +46 8404 1600
Fax: +46 8984 281
info@aratron.se
www.aratron.se
Contact: Mr. Niklas Granström

HAHN Gasfedern GmbH
Waldstrasse 39-43
73773 Aichwald
GERMANY

Phone: +49 711 936705-0
Fax: +49 711 936705-40

info@hahn-gasfedern.de
www.hahn-gasfedern.de