

SYK[®]

Professional manufacturer **2024**



**BALL SCREW
O.D UP TO 50 MM**

(Our products don't Contain hazardous substance restricted by RoHS.)



Price List

For enquiry of price, please visit www.syk-tw.com

New Product Information

一. Motor Bracket MBCS25/30 / MBCF30 (Long Type)-P14

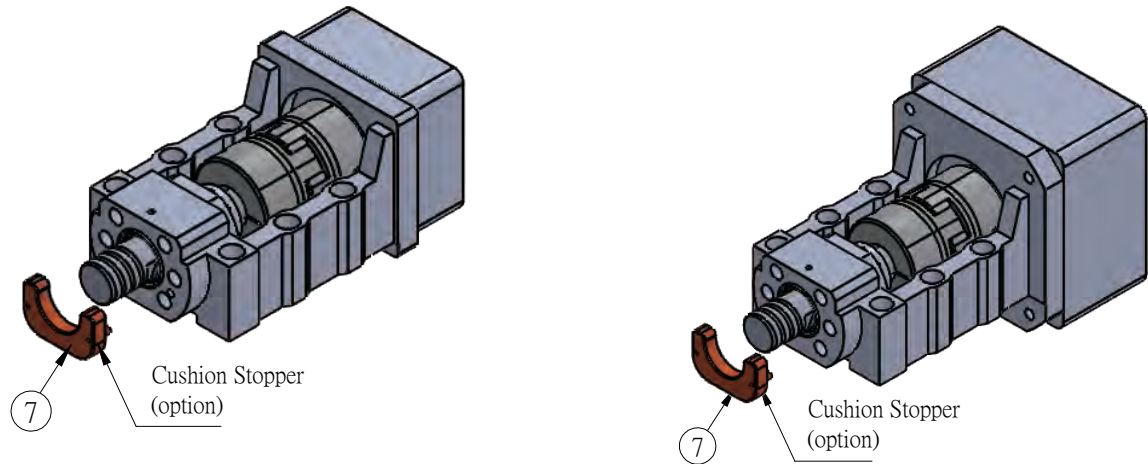

二. Motor Bracket MBCK25/30/35/40-P16

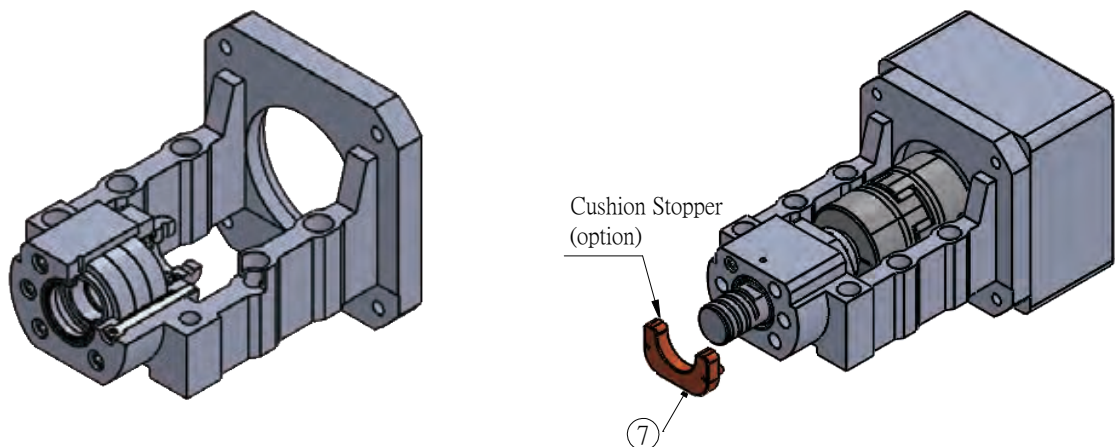

三. Motor Bracket MBCS35/40-P17

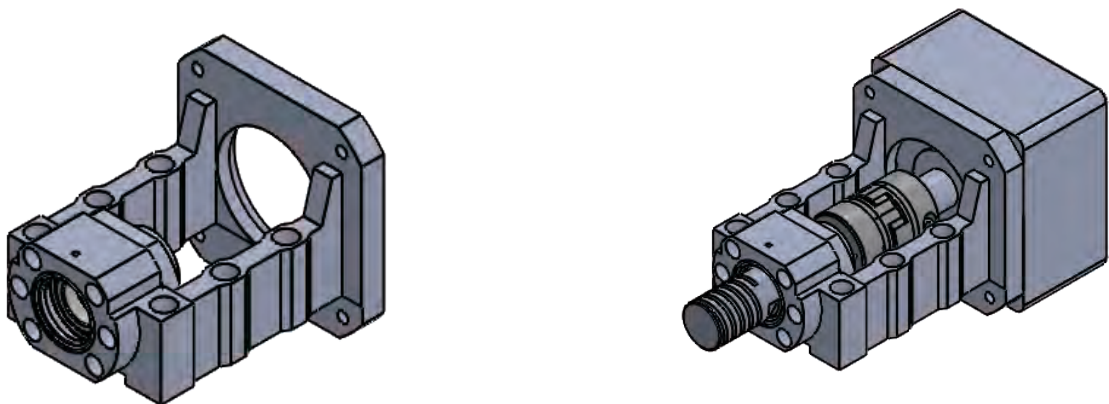

四. MBCF20H & MBCS20H-P11 、 SK20-P39 、 SF20-P36 For "Mineral Casting" Base

Index

- Motor Bracket MBCA15/20 1
- Motor Bracket MBCB 12 / Motor Bracket MBCB 15 4
- Motor Bracket MBCE 10/12 / Motor Bracket MBCF 10/12 / Motor Bracket MBCE 15 6
- Motor Bracket MBCS 15/17/20 / Motor Bracket MBCF .20..... 9
- Motor Bracket MBC20H / MBC25 11
- Motor Bracket MBCS25/30 / MBCF30 / Motor Bracket(Long Type) MBCS25/30 / MBCF30..... 13
- Motor Bracket MBCK 25/30/35/40 16
- Motor Bracket MBCS35/40 17
- Recommended Shaft End Shape (Fixed side) for MBC Types / MBC(Long Type)..... 18
- Motor Bracket MBA Series (Narrow Type)..... 20
- Motor Bracket MBB Series (Hidden Type) 21
- Motor Bracket MBL Series (Low Narrow Type)..... 22
- Motor Bracket MBH 23
- Motor Bracket MB series and Corresponding Motor Reference Table 24
- Characteristic Values of (Fixed-side) Support Units and Bearing27
- Rectangular Support Unit AK Type (Fixed-side) / AF series (Supported-side)..... 29
- Rectangular Support Unit BK Type (Fixed-side) / BF series (Supported-side)..... 33
- Support Unit HF Type (Rectangular Type)..... 38
- Rectangular Support Unit EK Type (Fixed-side) / EF series (Supported-side)..... 39
- Round Support Unit FK Type (Fixed-side) / FF series (Supported-side)..... 44
- Round Support Unit FKA Type (Fixed-side) 50
- Rectangular & Low Profile Support Unit LK Type (Fixed-side) 53
- Rectangular & Low Profile Support Unit LF / LFA type (Supported-side) 55
- Heavy Load Support Unit WBK Type 57
- Heavy Load Support Unit SBK Type 59
- Heavy Load Support Unit MBK Type (With Motor Bracket)..... 61
- Standard Lock Nut / Heavy Load Lock Nut..... 63
- Recommended Shaft End Shape for Fixed-side Support Unit..... 66
- Recommended Shaft End Shape for Supported-side Support Unit 68
- Recommended Shaft End Shape for Heavy Load Support Unit 69
- Support Unit Equivalent Interchangeable for Major Manufacturer 70
- Nut Bracket MC / MGD Type..... 71
- SGS-C Disk/Clamp Type / Shorter Flexible Coupling..... 73
- SGL-C Disk/Clamp Type / Longer Flexible Coupling..... 75
- Ball Screw Actuator 77
- Quality Test of Support Unit 80

Example of identification number Support unit :								
BK30B_C5 G N C A S M								
	①	②	③	④	⑤	⑥	⑦	⑧
①	B	Contact Angle B 40°						
②	C5	Accuracy Grade						
③	G	Grease Fitting						
④	N	Electroless Nickel Plating						
⑤	C	Clean Room Grease						
⑥	A	Aluminum						
⑦	S	Stainless Steel						
⑧	M	Custom made or with Motor Bracket						

Example of identification number Motor bracket :						
MBCB12-D g N C J						
	①	②	③	④	⑤	⑥
①	B	Equivalent to BK type support unit				
	E	Equivalent to EK type support unit				
②	D	Servo motor specification code				
③	g	Grease Fitting				
④	N	Electroless Nickel Plating				
⑤	C	Clean Room Grease				
⑥		Taiwanese brand P5 bearing				
	J	Japanese brand P5 bearings				

Usage Note

- Do not disassemble the Support Unit of LK,EK,BK,FK,FKA,AK,CKD,MBC.
- The Bearing of LK,EK,BK,FK,FKA,AK,CKD,MBC are filled up grease.
- When inserting a screw shaft into Support Unit, take care to prevent peeling the oil-seal lip.

Motor Bracket MBCA15 / 20

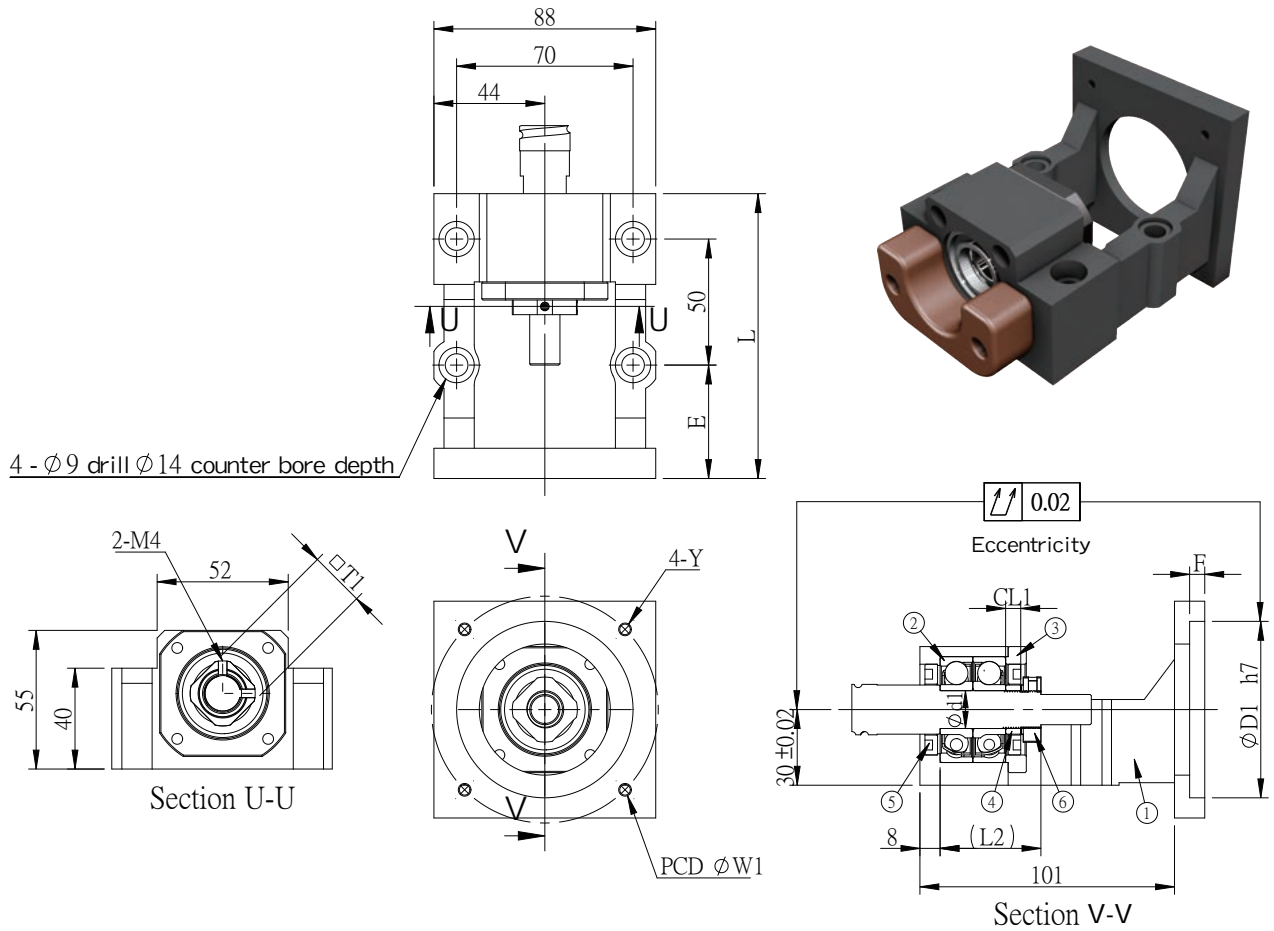

No.	Part name	Qty
1	Housing	1
2	Bearing MBCA15 (7302A) MBCA20 (7004A)	1 set
3	Holding lid	1
4	Collar	2
5	Seal	2
6	Lock nut	1set
7	Cushion Stopper (option)	1

Heavy load

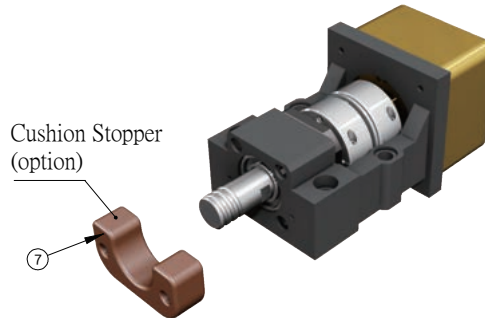

Unit : mm

Model No.	D1	W1	Y	L	Shaft diameter d1	CL1	L2	E	F	T1	Weight (Kgs)	Support unit / Supported-side	Suggest Coupling
MBCA15-E	70	90	M6	115	15	6	40	47	8	22	1.95	AK15/AF15	SGS 50C
MBCA15-EP	70	90	M5	113				45	6				
MBCA15-X	80	100	M6	115				47	8				
MBCA20-E	70	90	M6	115	20	8	43	47	8	30	1.98	AK20/AF20	SGS 50C
MBCA20-EP	70	90	M5	113				45	6				
MBCA20-X	80	100	M6	115				47	8				

Note :

1. The matched bearing in the support unit has already done the preload.
2. The matched P5 bearings are assembled in DF way, which is the most suitable for ball screw use.

Illustration for MBCA15

Fixed+Fixed

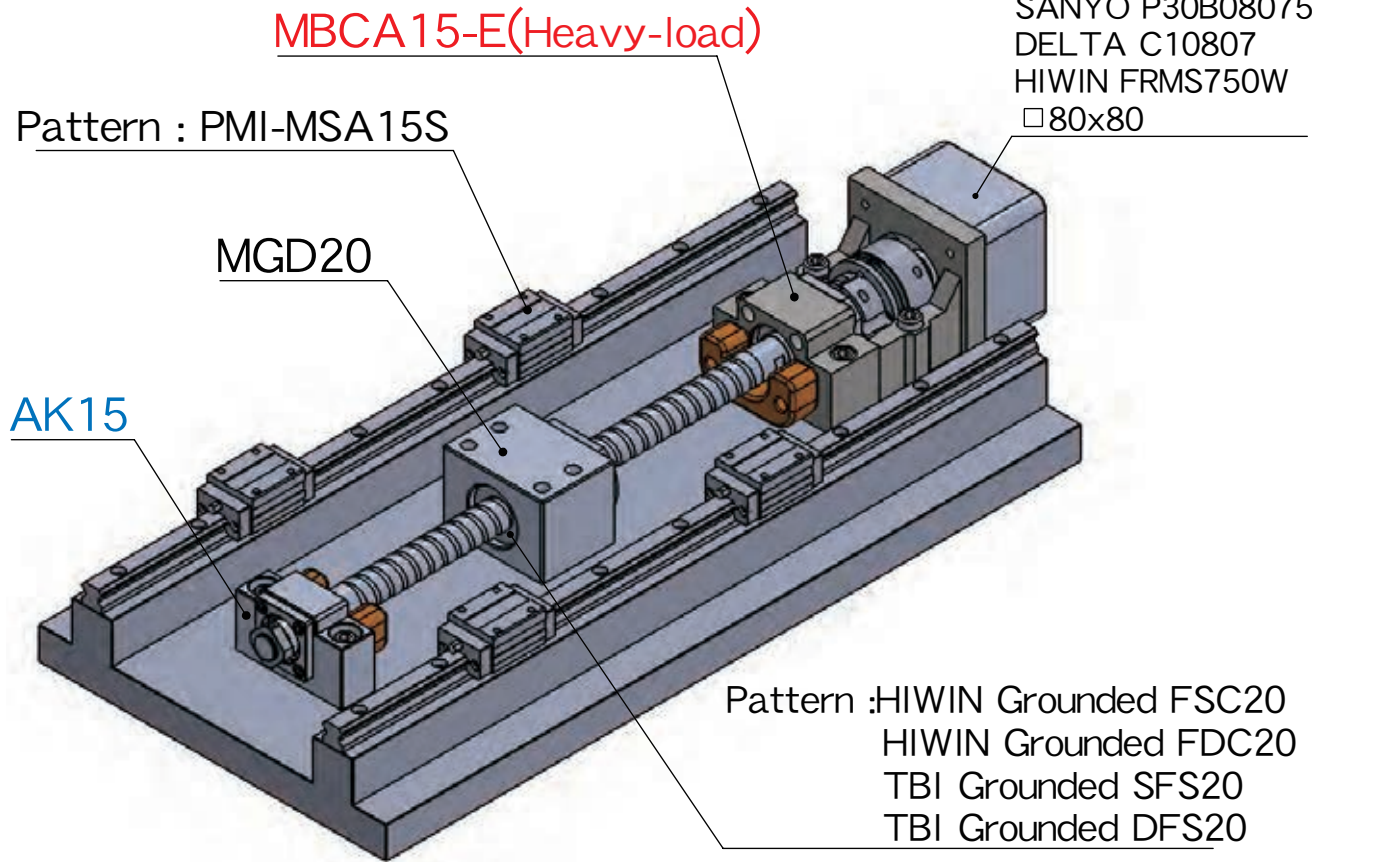

Fixed+Supported

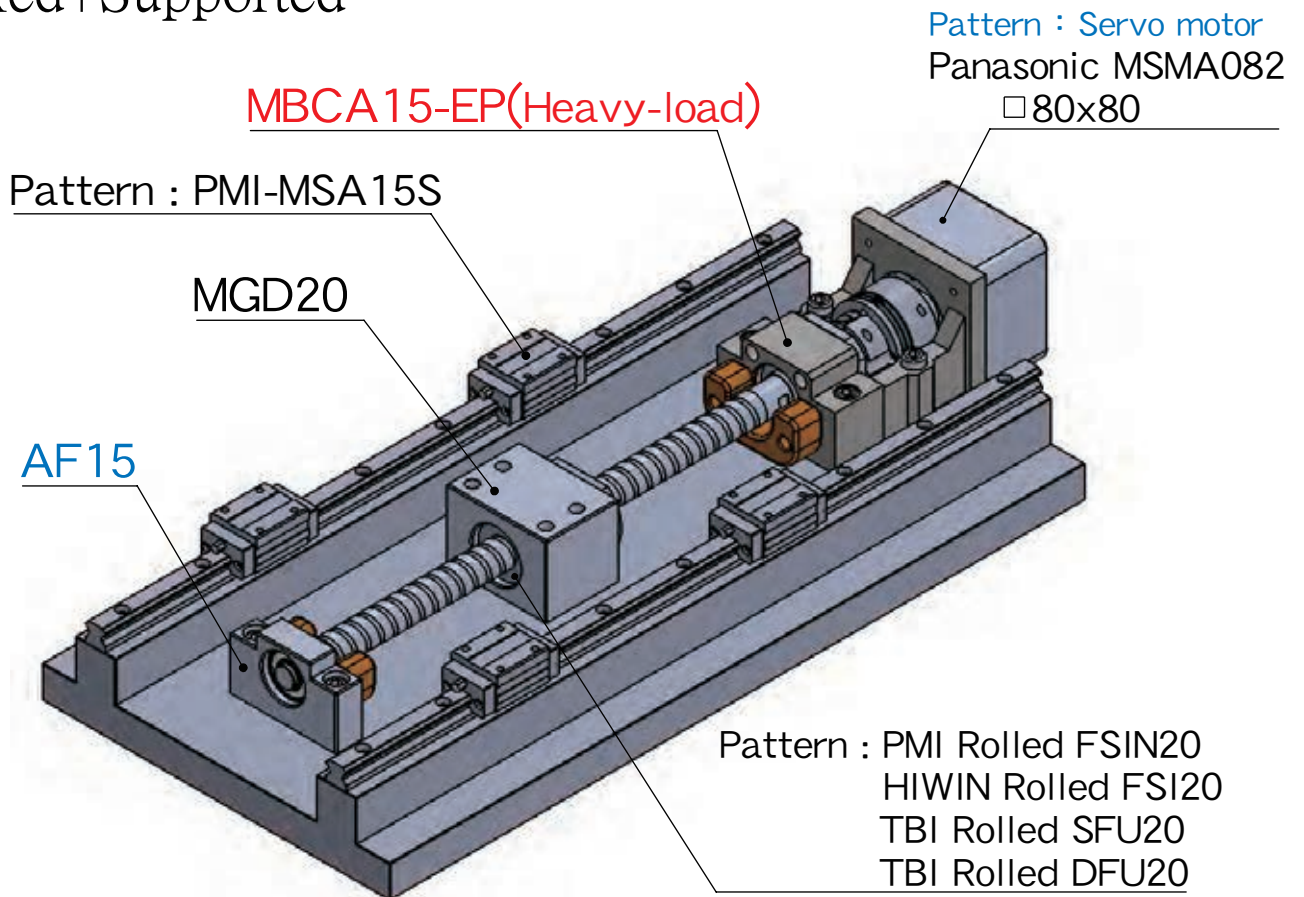
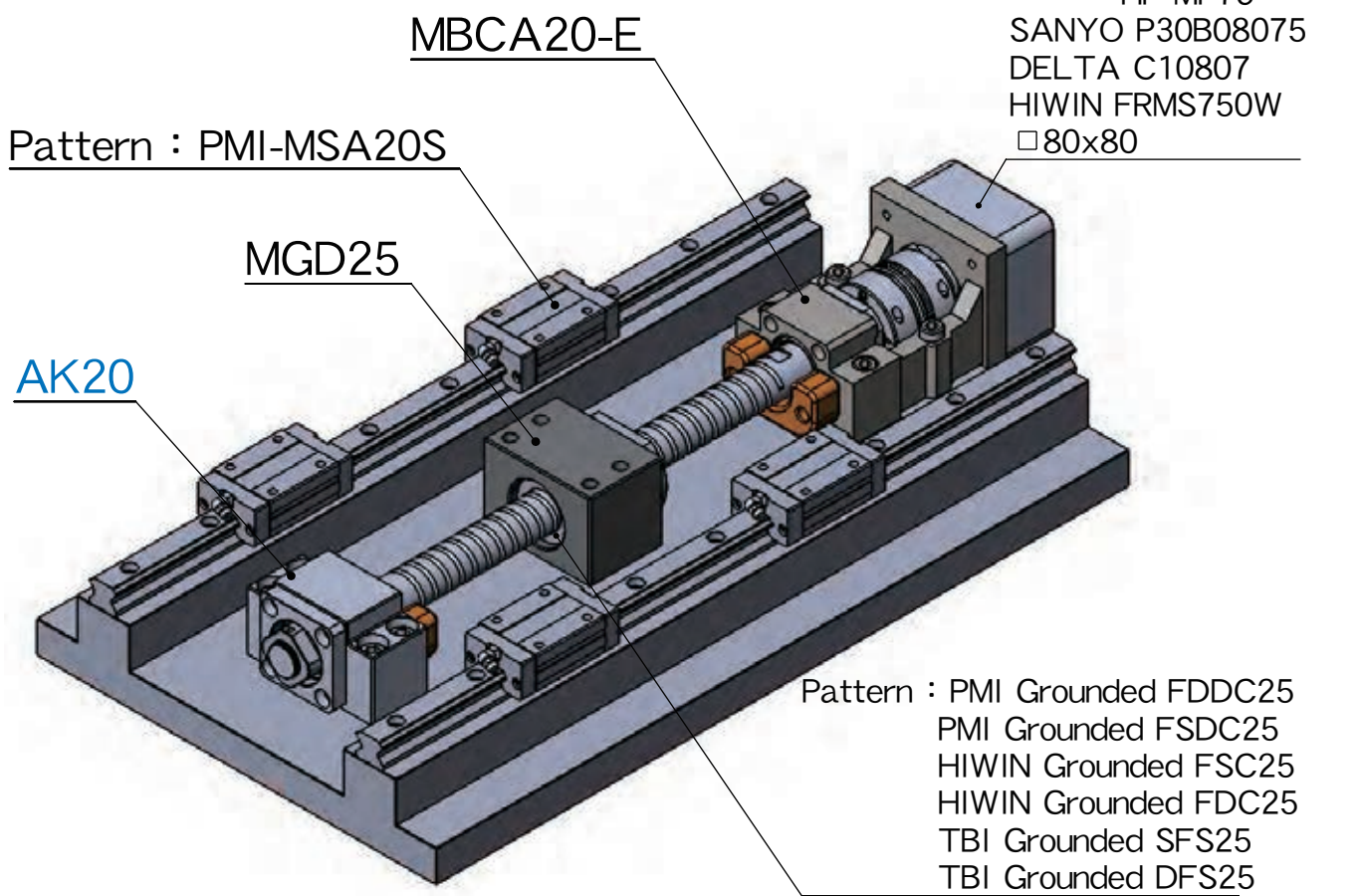
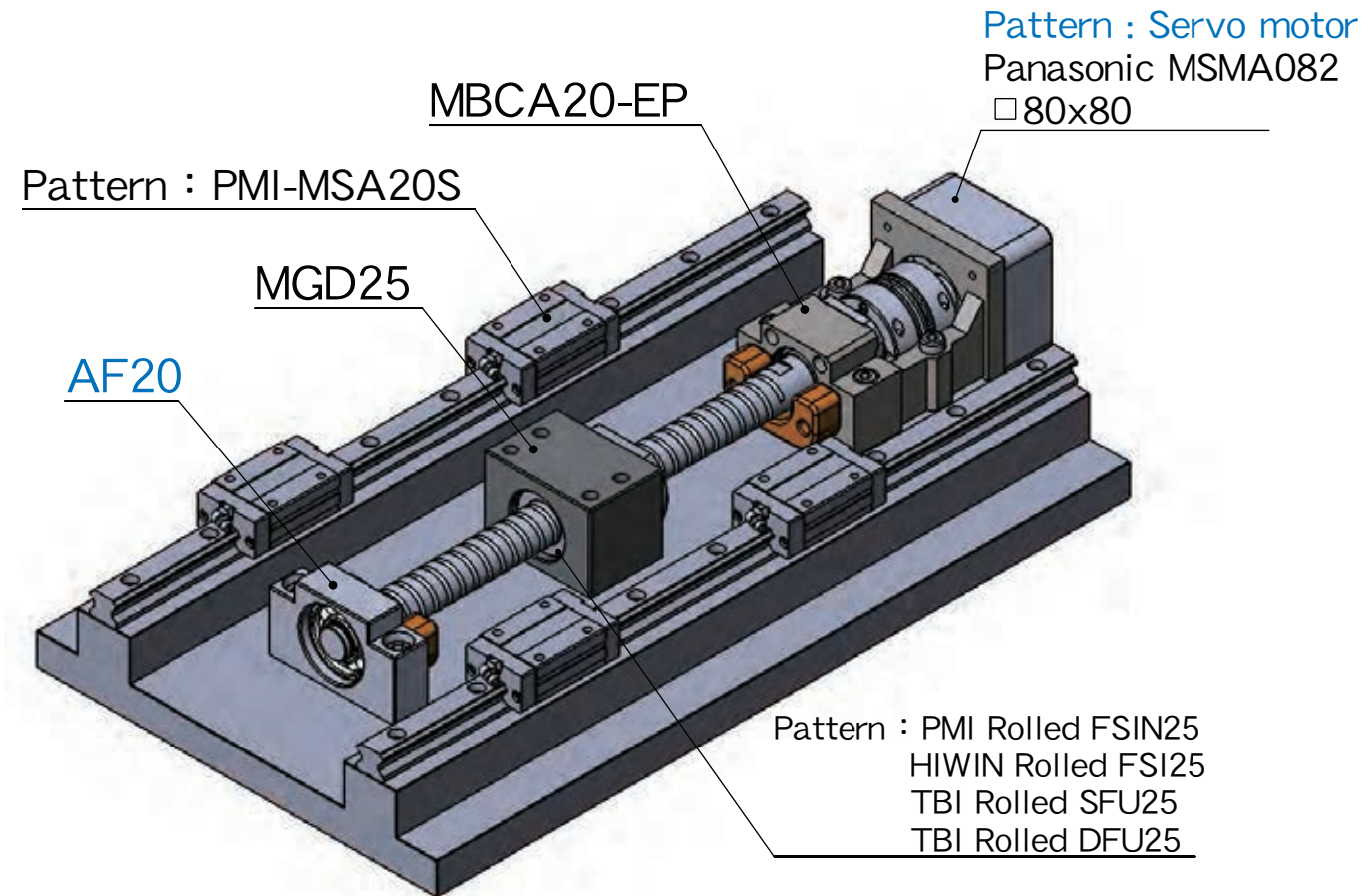

Illustration for MBCA20

Fixed+Fixed



Fixed+Supported



Motor Bracket MBCB12

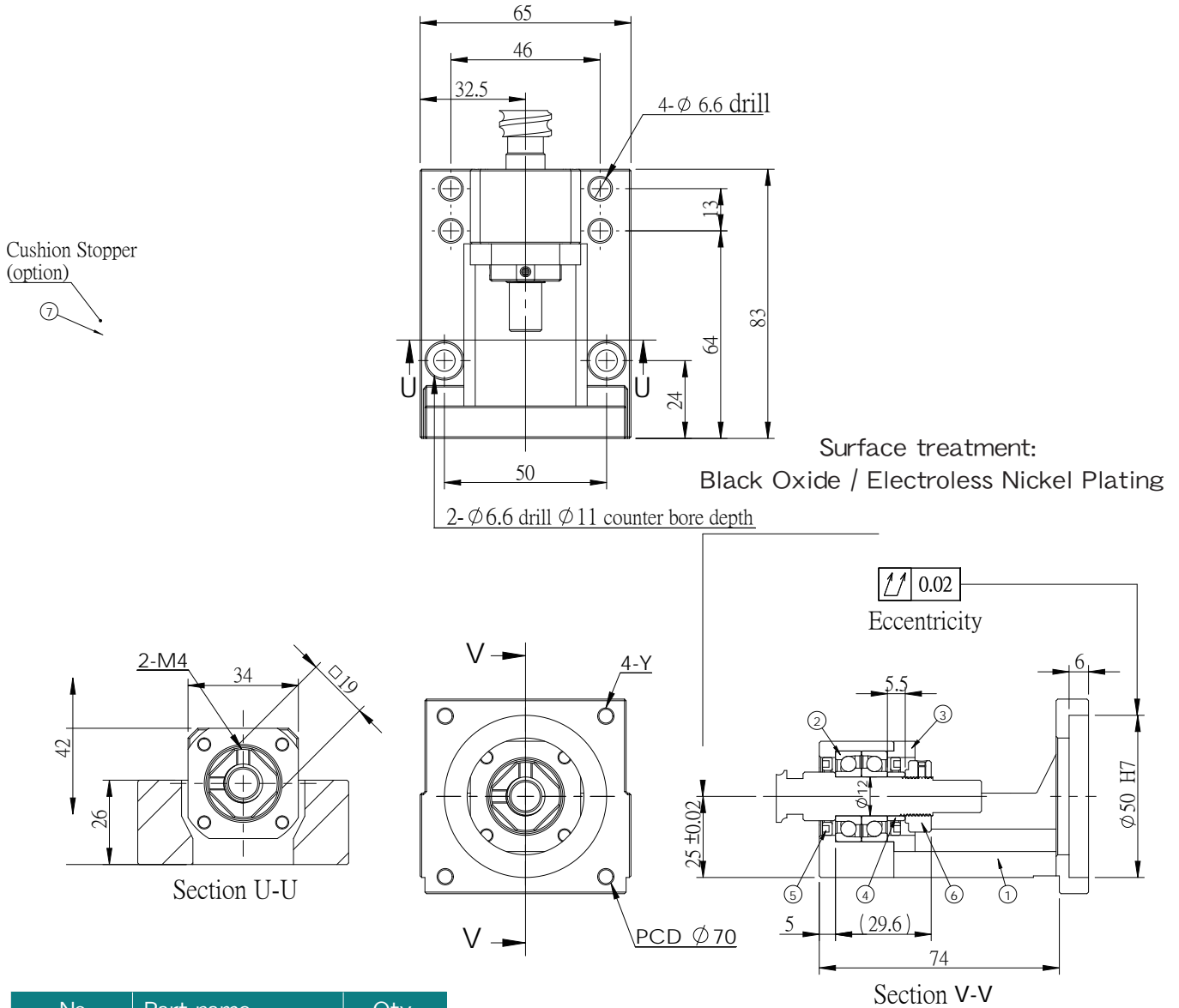

No.	Part name	Qty
1	Housing	1
2	7001 Bearing	1 set
3	Holding lid	1
4	Collar	2
5	Seal	2
6	Lock nut	1set
7	Cushion Stopper (option)	1

Unit : mm

Model No.	Y	Weight (Kgs)	Support unit	Suggest Coupling
			Supported-side	
MBCB12-D	M5	0.8	BF12	SGS 34C
MBCB12-DP	M4			

Note :

1. The matched bearing in the support unit has already done the preload.
2. The matched P5 bearings are assembled in DF way, which is the most suitable for ball screw use.

Motor Bracket MBCB15

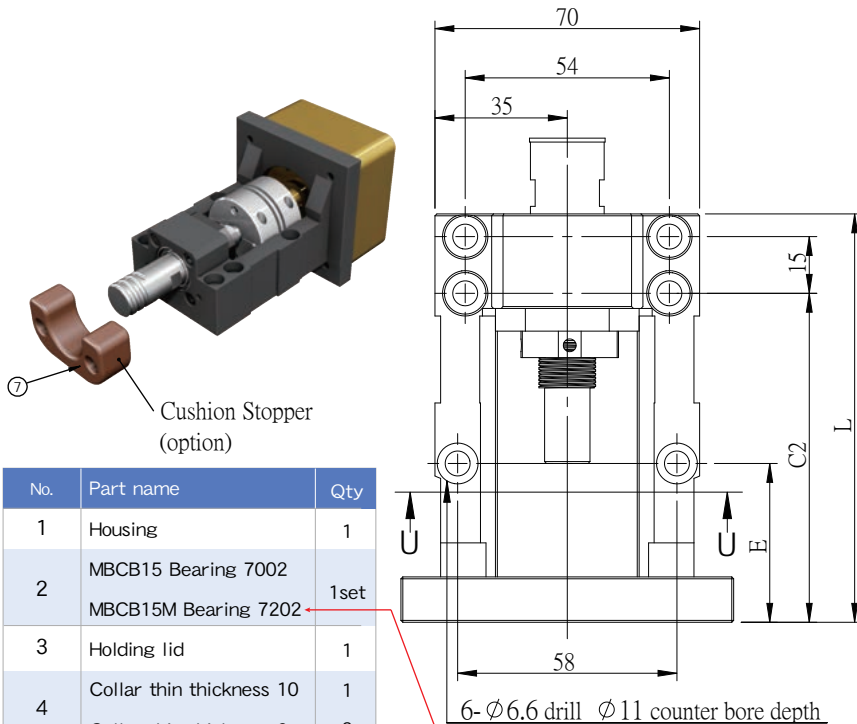

Surface treatment:
Black Oxide /
Electroless Nickel Plating

No.	Part name	Qty
1	Housing	1
2	MBCB15 Bearing 7002	1set
	MBCB15M Bearing 7202	
3	Holding lid	1
4	Collar thin thickness 10	1
	Collar thin thickness 6	2
5	Seal	2
6	Lock nut	1set
7	Cushion Stopper (option)	1

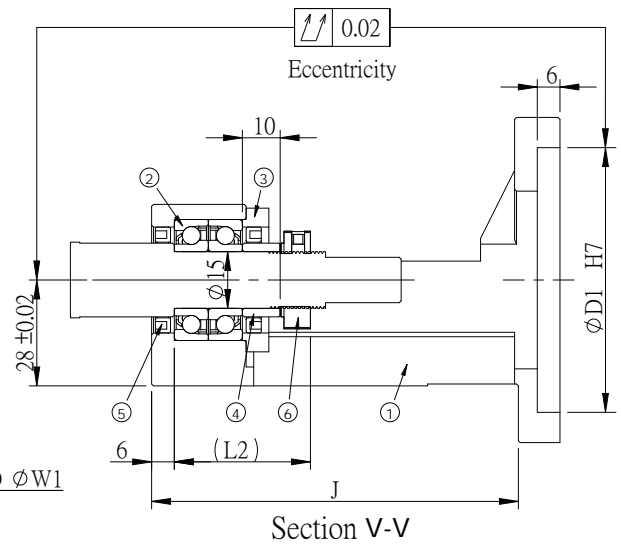
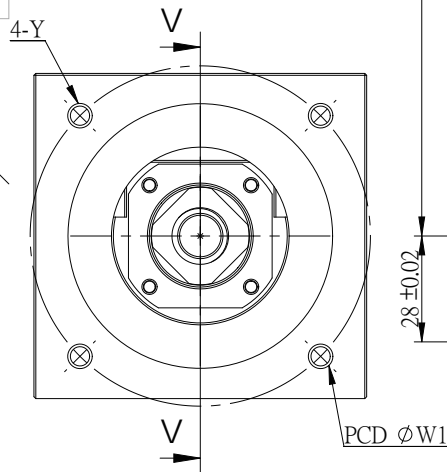
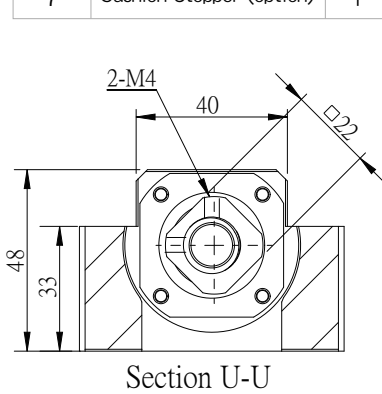

Unit : mm

Model No.	D1	W1	Y	L	L2	E	C2	J	Weight (Kgs)	Support unit	Suggest Coupling
										Supported-side	
MBCB15-D	50	70	M5	98	36	32	77	89	0.98	BF 15	SGS 34C SGS 40C
MBCB15-DP			M4								
MBCB15-E	70	90	M6	108	36	42	87	97	1.39	BF 15	SGS 40C SGS 45C
MBCB15-EP			M5								
MBCB15M-E	70	90	M6	110	40	44	89	99	1.46	BF 15	SGS 40C SGS 45C
MBCB15M-EP			M5								

Note :

1. The matched bearing in the support unit has already done the preload.
2. The matched P5 bearings are assembled in DF way, which is the most suitable for ball screw use.

Motor Bracket MBCE10/12、MBCF10/12

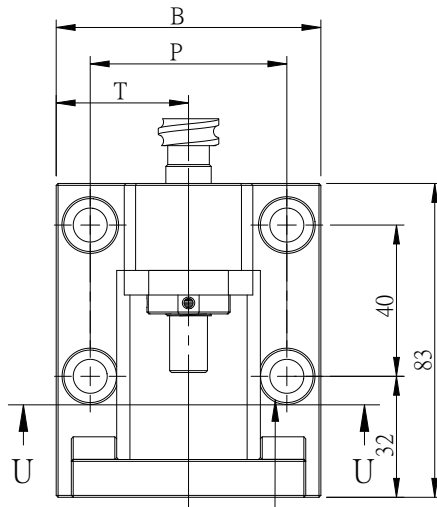
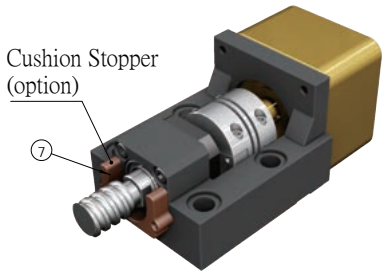

Surface treatment:
Black Oxide
/
Electroless Nickel Plating

No.	Part name	Qty
1	Housing	1
2	Bearing	
	MBC*10 with bearings 7000	1 set
	MBC*12 with bearings 7001	
3	Holding lid	1
4	Collar	2
5	Seal	2
6	Lock nut	1set
7	Cushion Stopper (option)	1

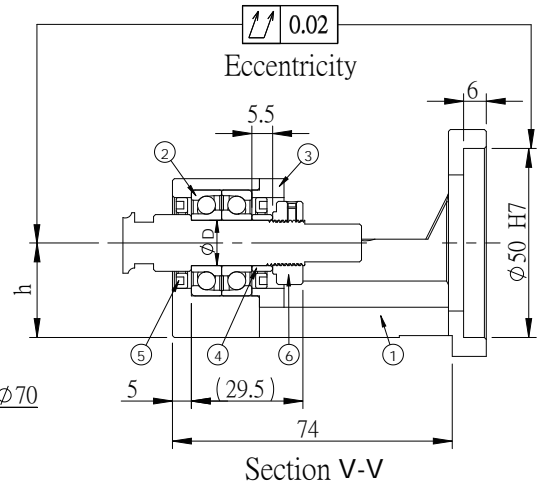
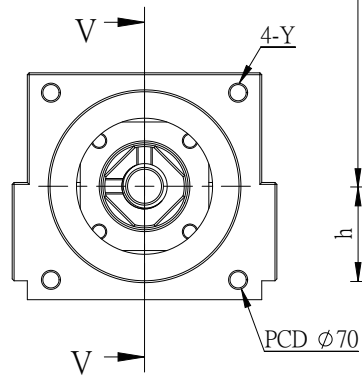
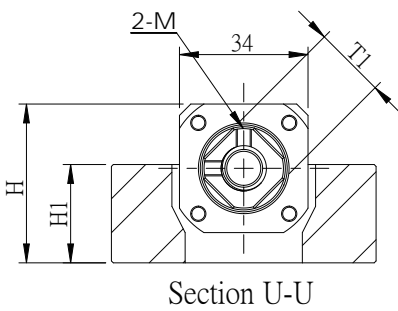

Unit : mm

Model No.	B	P	T	H	H1	h ±0.02	φD	T1	M	Y	S	Q	Weight (Kgs)	Support unit	Suggest Coupling
														Supported-side	
MBCE10-D	70	52	35	42	26	25	10	□16	M3	M5	9	14	0.89	EF10	SGS 34C
MBCE10-DP														AF 10	
MBCE12-D	70	52	35	42	26	25	12	□19	M4	M5	9	14	0.86	EF12	SGS 34C
MBCE12-DP														AF 12	
MBCF10-D	63	50	31.5	37	21	20	10	□16	M3	M5	6.6	11	0.69	LF12	SGS 34C
MBCF10-DP														LFA 15	
MBCF12-D	63	50	31.5	37	21	20	12	□19	M4	M5	6.6	11	0.68	LF12	SGS 34C
MBCF12-DP														LFA 15	

Note :

1. The matched bearing in the support unit has already done the preload.
2. The matched P5 bearings are assembled in DF way, which is the most suitable for ball screw use.

Illustration for MBCF10/12

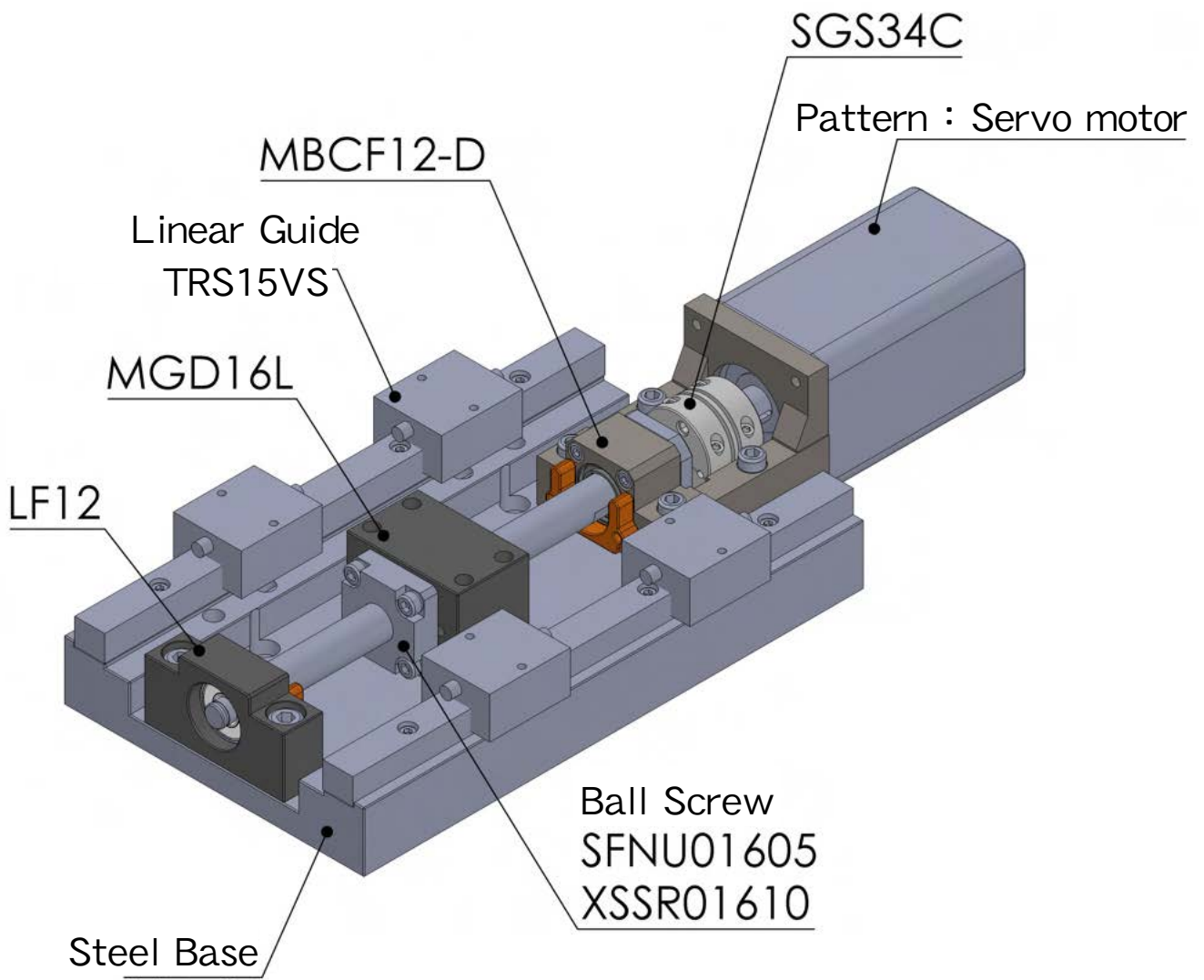

Motor Bracket MBCE15

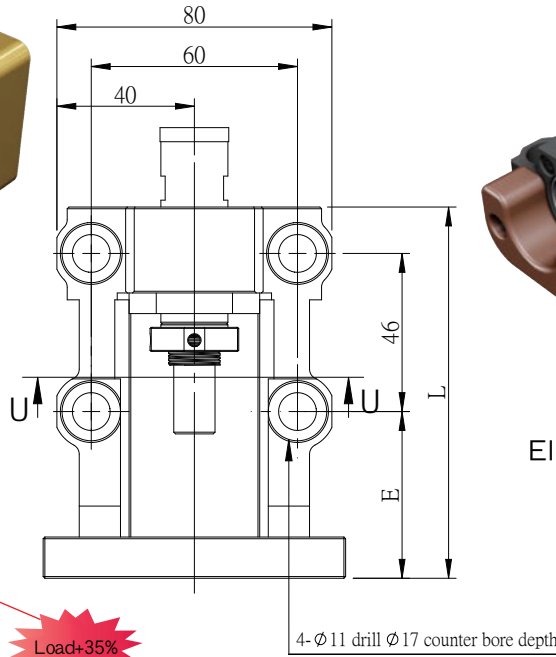
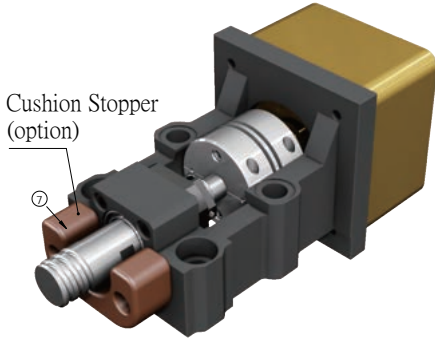

Surface treatment:
Black Oxide /
Electroless Nickel Plating

No.	Part name	Qty
1	Housing	1
2	Bearing	1 set
	MBCE15 with bearings 7002	
	MBCE15M with bearings 7202	
3	Holding lid	1
4	Collar	2
5	Seal	2
6	Lock nut	1set
7	Cushion Stopper (option)	1

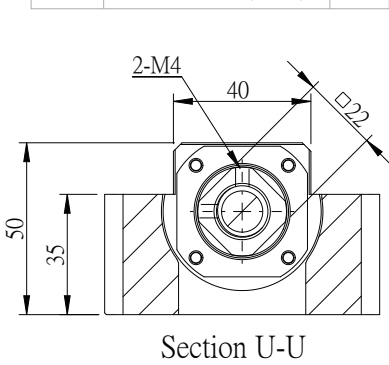

Section U-U

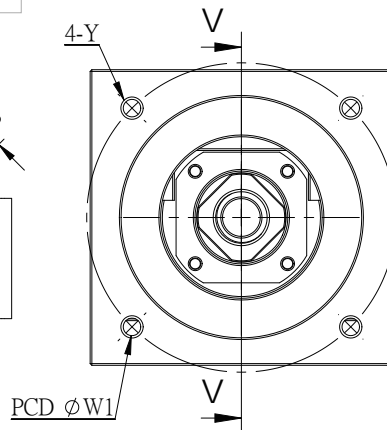

PCD φW1

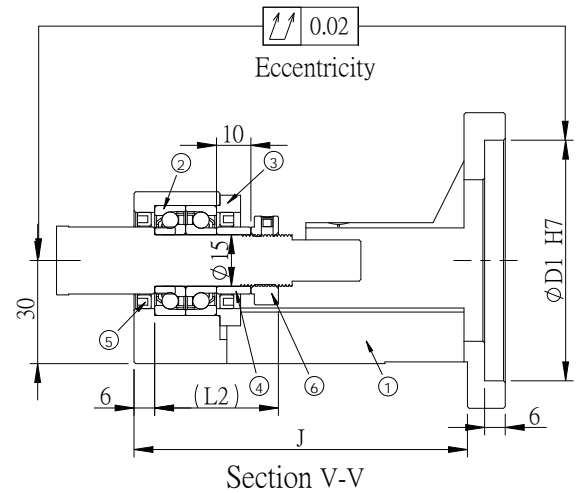

Section V-V

Unit : mm

Model No.	D1	W1	Y	L	L2	E	J	Weight (Kgs)	Support unit	Suggest Coupling
									Supported-side	
MBCE15-D	50	70	M5	98	36	38.5	flat	1.09	EF 15 AF 15	SGS 34C SGS 40C
MBCE15-DP			M4							
MBCE15-E	70	90	M6	108	48.5	97	1.54	EF 15 AF 15	SGS 40C SGS 45C	
MBCE15-EP			M5							
MBCE15M-E	70	90	M6	110	40	50.5	99	1.61	EF 15 AF 15	SGS 40C SGS 45C
MBCE15M-EP			M5							

Note :

1. The matched bearing in the support unit has already done the preload.
2. The matched P5 bearings are assembled in DF way, which is the most suitable for ball screw use.

Motor Bracket MBCS15/17/20 / MBCF20

Fig→Fixed+Fixed

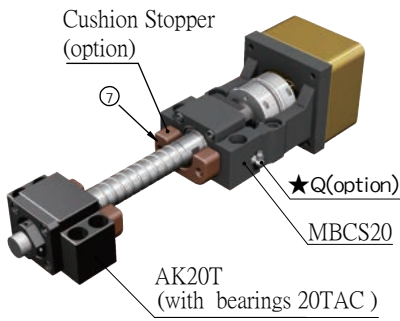

Fig→Fixed+Supported

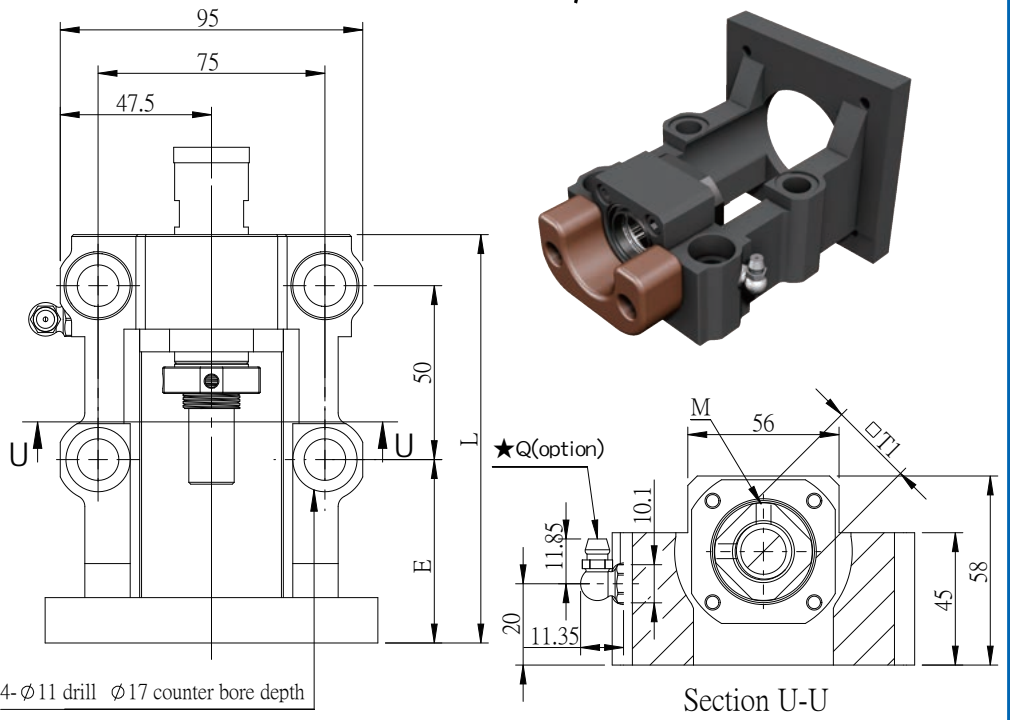
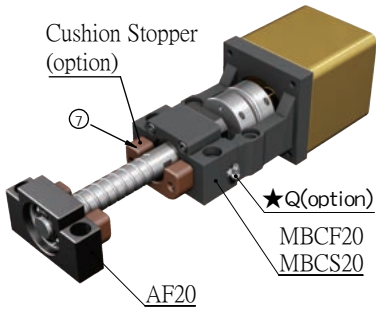

No.	Part name	Qty
1	Housing	1
2	Bearing MBCS15 with bearings 15TAC MBCS17 with bearings 17TAC MBCF20 with bearings 7204 MBCS20 with bearings 20TAC	1set
3	Holding lid	1
4	Collar	2
5	Seal	2
6	Lock nut	1set
7	Cushion Stopper (option)	1

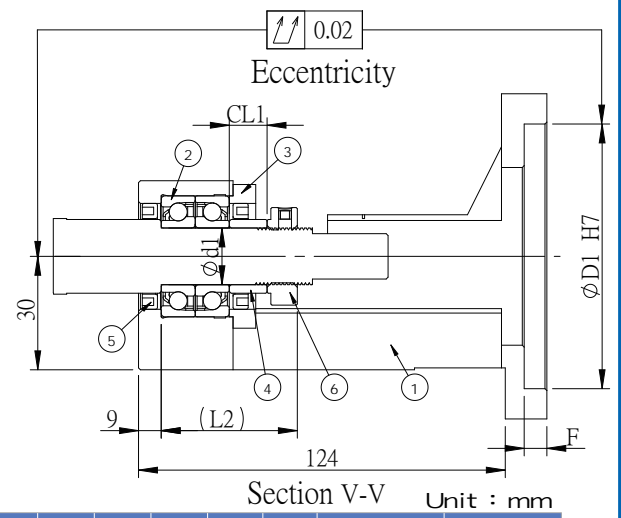
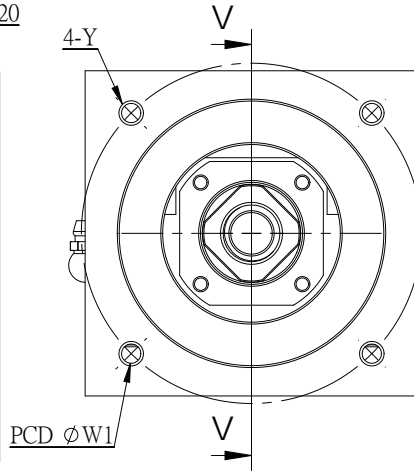

Model No.	D1	W1	Y	L	Shaft diameter d1	CL1	L2	E	F	M	T1	Q	Weight (Kgs)	Support unit Supported-side	Suggest Coupling
MBCS15-X	80	100	M6	140	15	9	47	70	8	2-M4	□22	-	2.77	AF 15 EF 15	SGS 50C
MBCS15-Y	95	115	M8	141				71					SGS 50C		
MBCS15-YP			M6	141				71					SGS 57C		
MBCS15-S	110	130	M8	151	81	10	-	M6	-	-	-	-	-	-	SGS 57C
MBCS15-G		145	M8	153	83										SGS 57C
MBCS17-X	80	100	M6	140	17	9	57	70	8	4-M6	φ36	-	2.7	-	SGS 50C
MBCS17-Y	95	115	M8	141				71					SGS 50C		
MBCS17-YP			M6	141				71					SGS 57C		
MBCS17-S	110	130	M8	151	81	10	-	M6	-	-	-	-	-	-	SGS 57C
MBCS17-G		145	M8	153	83										SGS 57C
MBCF20-X	80	100	M6	140	20	11	50	70	8	2-M4	□30	-	2.77	EF 20 AF 20	SGS 50C
MBCF20-Y	95	115	M8	141				71					SGS 50C		
MBCF20-YP			M6	141				71					SGS 57C		
MBCF20-S	110	130	M8	151	81	10	-	M6	-	-	-	-	-	-	SGS 57C
MBCF20-G		145	M8	153	83										SGS 57C
MBCS20-X	80	100	M6	140	20	9	57	70	8	4-M6	φ40	-	2.8	AK20T AF20 EF20	SGS 50C
MBCS20-Y	95	115	M8	141				71					SGS 50C		
MBCS20-YP			M6	141				71					SGS 57C		
MBCS20-S	110	130	M8	151	81	10	-	M6	-	-	-	-	-	-	SGS 57C
MBCS20-G		145	M8	153	83										SGS 57C

Note : 1. The matched bearing in the support unit has already done the preload.
 2. The matched bearings are assembled in DF way, which is the most suitable for ball screw use.
 3. The accuracy of TAC bearing is P4 grade and 7204 is P5 grade.
 4. The standard type is without Q, if required, please advise in advance.

Illustration for MBC_20

Fixed+Fixed

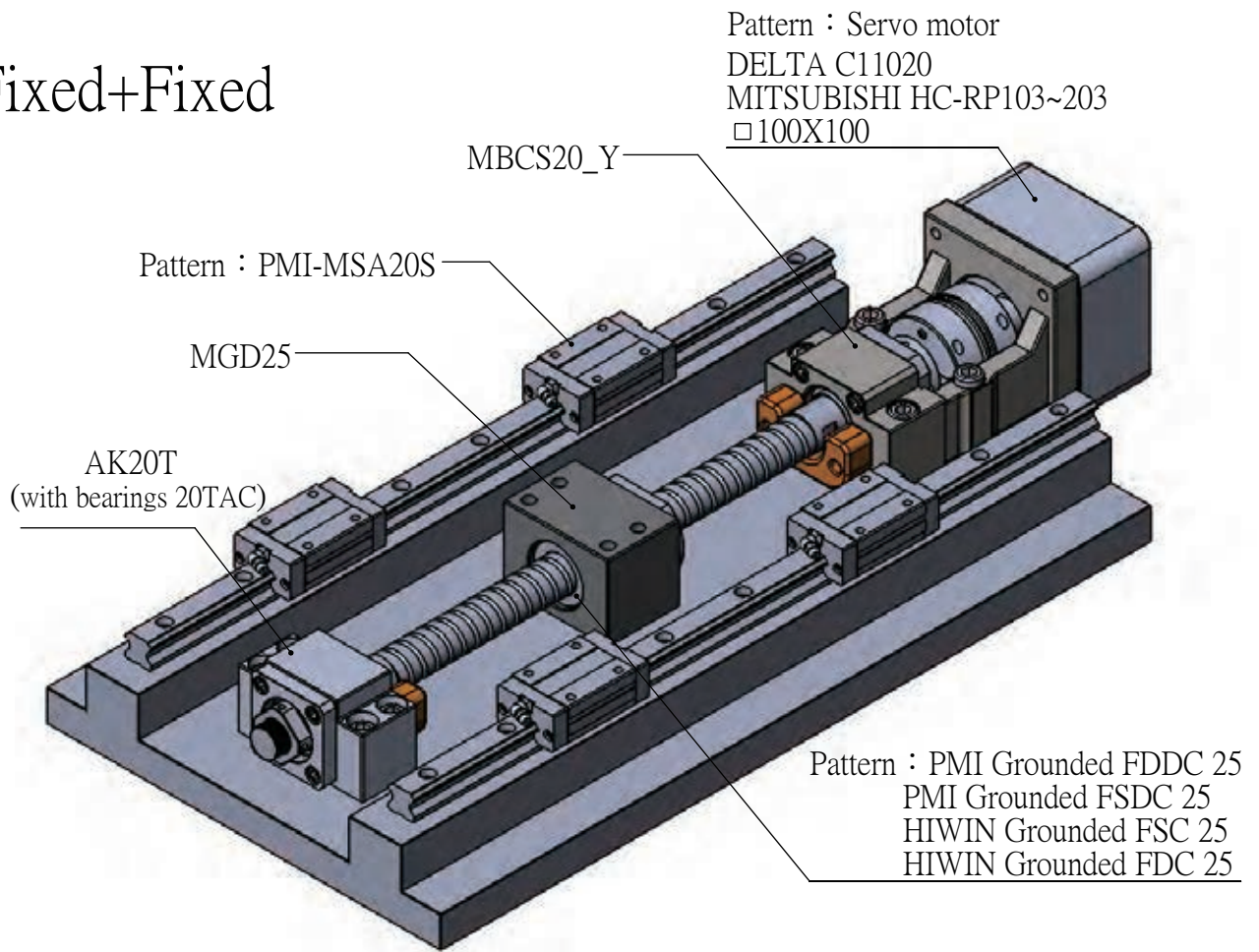

Fixed+Supported

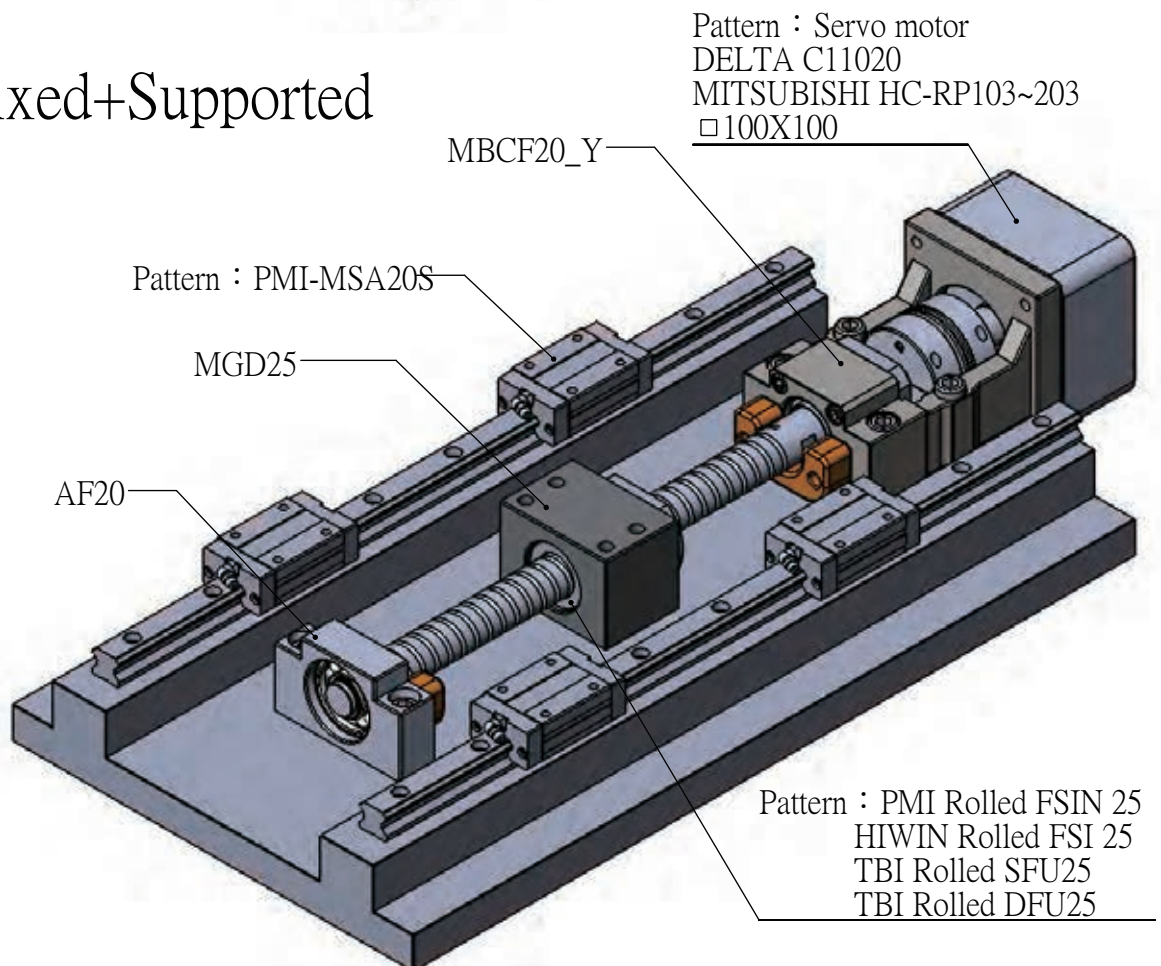

Motor Bracket MBC20H / MBC25

Fig→Fixed+Fixed

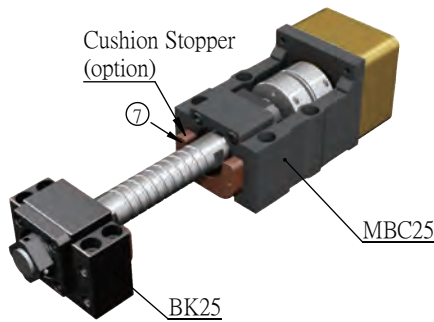

Fig→Fixed+Supported

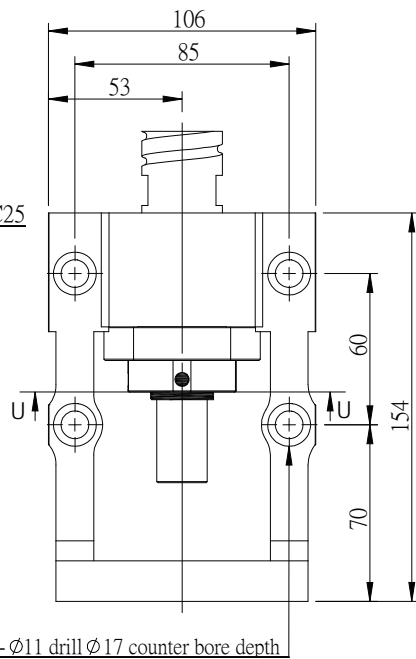
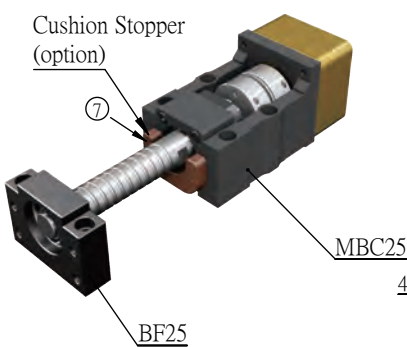

Surface treatment: Black Oxide

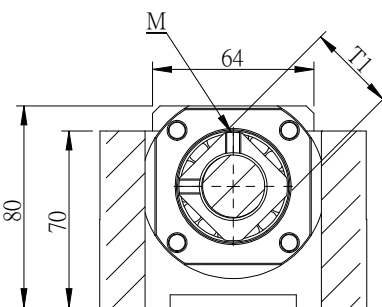

Section U-U

No.	Part name	Qty
1	Housing	1
2	Bearing	1set
	MBCF20H with bearings 7204	
	MBCS20H with bearings 20TAC	
	MBC25 with bearings 7205	
3	Holding lid	1
4	Collar	2
5	Seal	2
6	Lock nut	1set
7	Cushion Stopper (option)	1

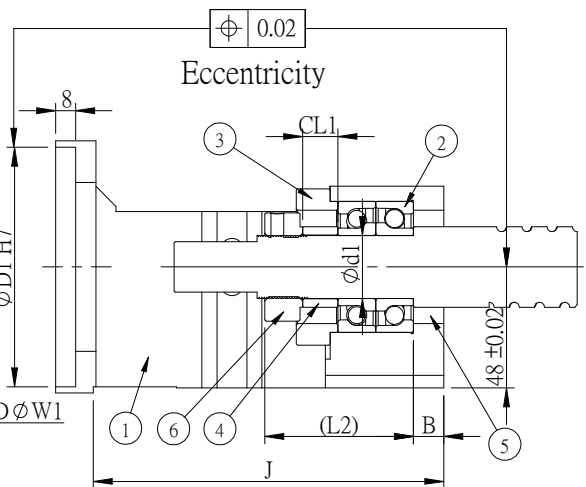
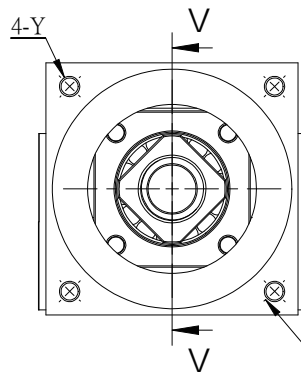

Section V-V

Unit : mm

Model No.	D1	W1	Y	J	Shaft diameter d1	CL1	B	L2	M	T1	Weight (Kgs)	Support unit		Suggest Coupling
												Supported-side		
MBCF20H-X	80	100	M6	flat	20	11	9	50	2-M4	□30	-	SK20	SF20	SGL 50C SGL 57C
MBCS20H-X														
MBC25-X	80	100	M6	flat	25	14	12	59	2-M6	□35	4.51	BK25 BF25	SGS 57C SGS 65C	
MBC25-Y														
MBC25-YP														

Note : 1. The matched bearing in the support unit has already done the preload.

2. The matched bearings are assembled in DF way, which is the most suitable for ball screw use.

3. The accuracy of TAC bearing is P4 grade and 7204、7205 is P5 grade.



Illustration for MBC25

Fixed+Fixed

Pattern: Servo motor
 DELTA C11020
 MITSUBISHI HC-RP103~203
 □100X100

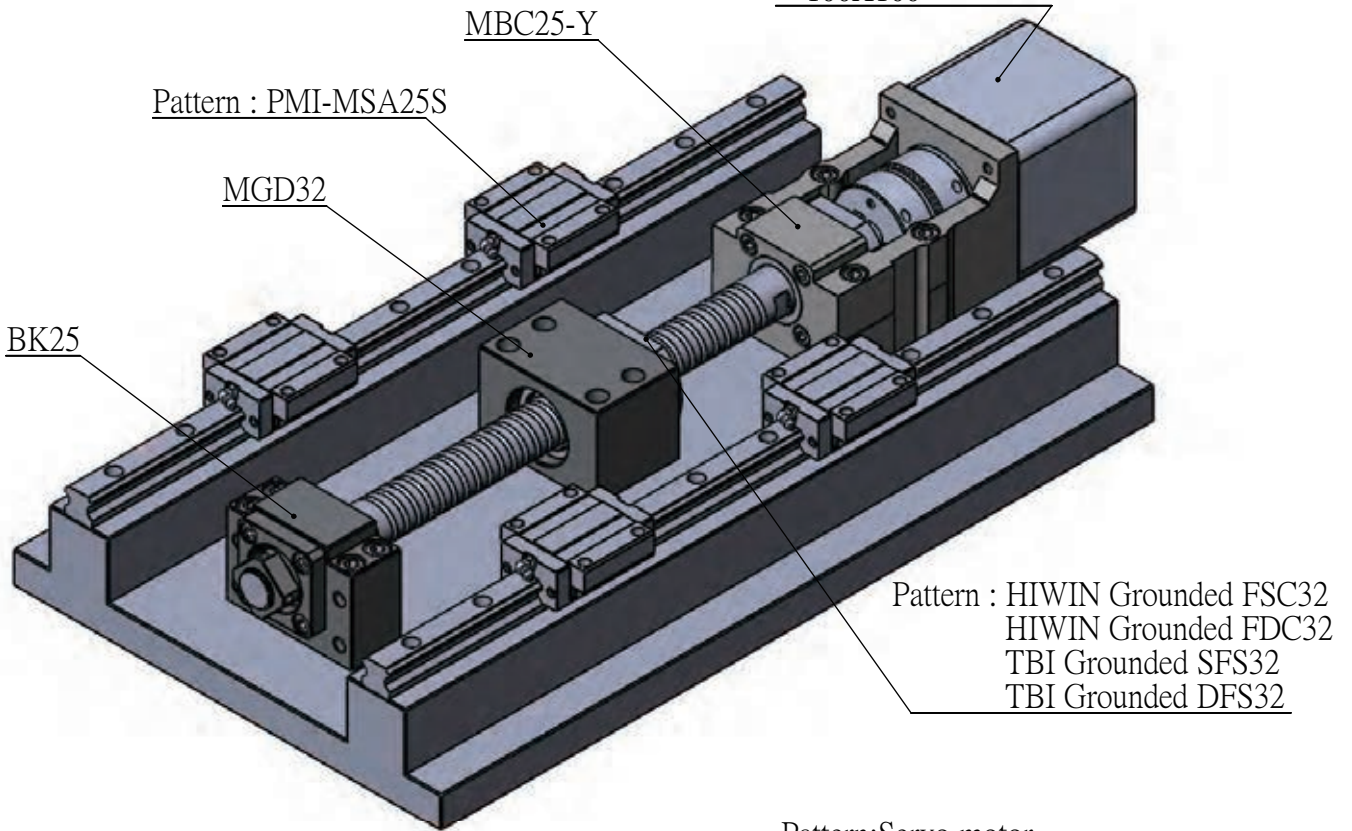

Fixed+Supported

Pattern: Servo motor
 DELTA C11020
 MITSUBISHI HC-RP103~203
 □100X100

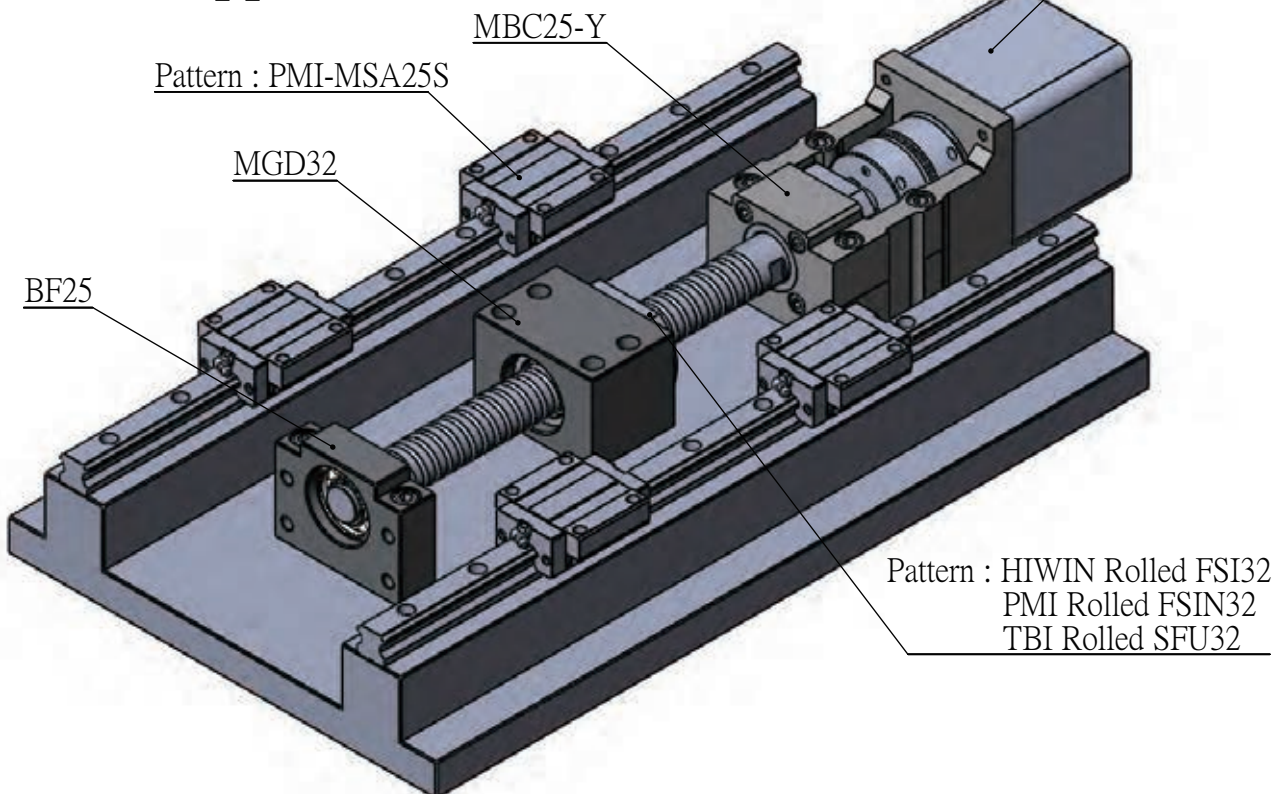

Motor Bracket MBCS25/30 / MBCF30

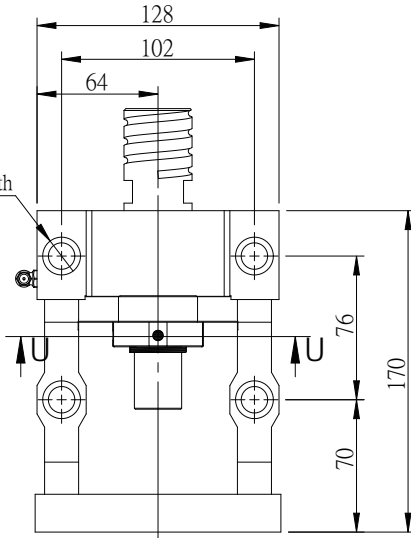
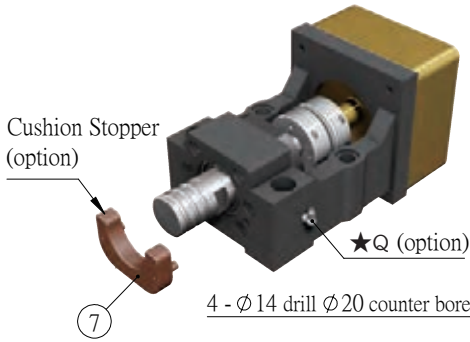

No.	Part name	Qty
1	Housing	1
2	Bearing MBCS25 with bearings 25TAC MBCS30 with bearings 30TAC MBCF30 with bearings 7206	1set
3	Holding lid	1
4	Collar	2
5	Seal	2
6	Lock nut	1set
7	Cushion Stopper (option)	1

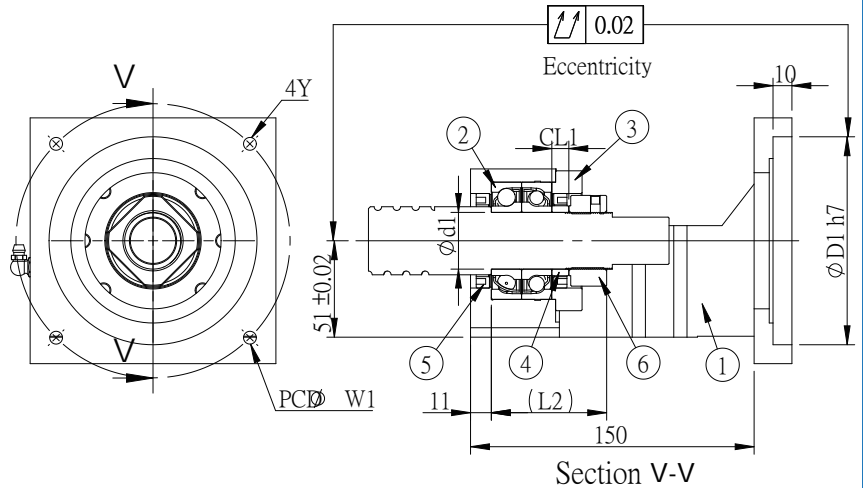
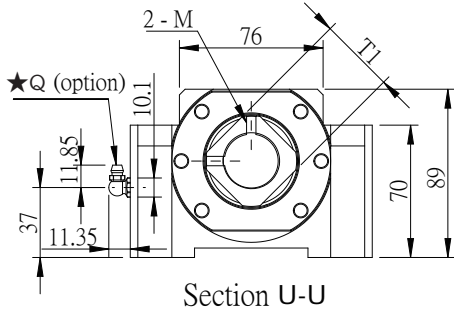

Unit : mm

Model No.	D1	W1	Y	Shaft diameter d1	CL1	L2	M	T1	Q	Weight (Kgs)	Support unit	Suggest		
											Supported-side	Coupling		
MBCS25-Y	95	115	M8	25	15	65	4-M6	φ45	-	6.75	SBK25 SF25	SGL 65C		
MBCS25-YP			M6											
MBCS25-S	110	130	M8										6.45	SGS 65C
MBCS25-G		145	M6											
MBCF30-Y	95	115	M8	30	9	61	2-M4	□40	-	6.56	BK30 BF30	SGL 65C		
MBCF30-YP			M6										6.35	
MBCF30-S	110	130	M8										-	SGS 65C
MBCF30-G		145	M6											
MBCS30-Y	95	115	M8	30	15	65	4-M6	φ50	-	-	SBK30 BF30	SGL 65C		
MBCS30-YP			M6										6.67	
MBCS30-S	110	130	M8										-	SGS 65C
MBCS30-G		145	M6											

- Note :
1. The matched bearing in the support unit has already done the preload.
 2. The matched bearings are assembled in DF way, which is the most suitable for ball screw use.
 3. The accuracy of TAC bearing is P4 grade and 7206 is P5 grade.
 4. The standard type is without Q , if required, please advise in advance.

Motor Bracket MBCS25/30 / MBCF30 (Long Type)

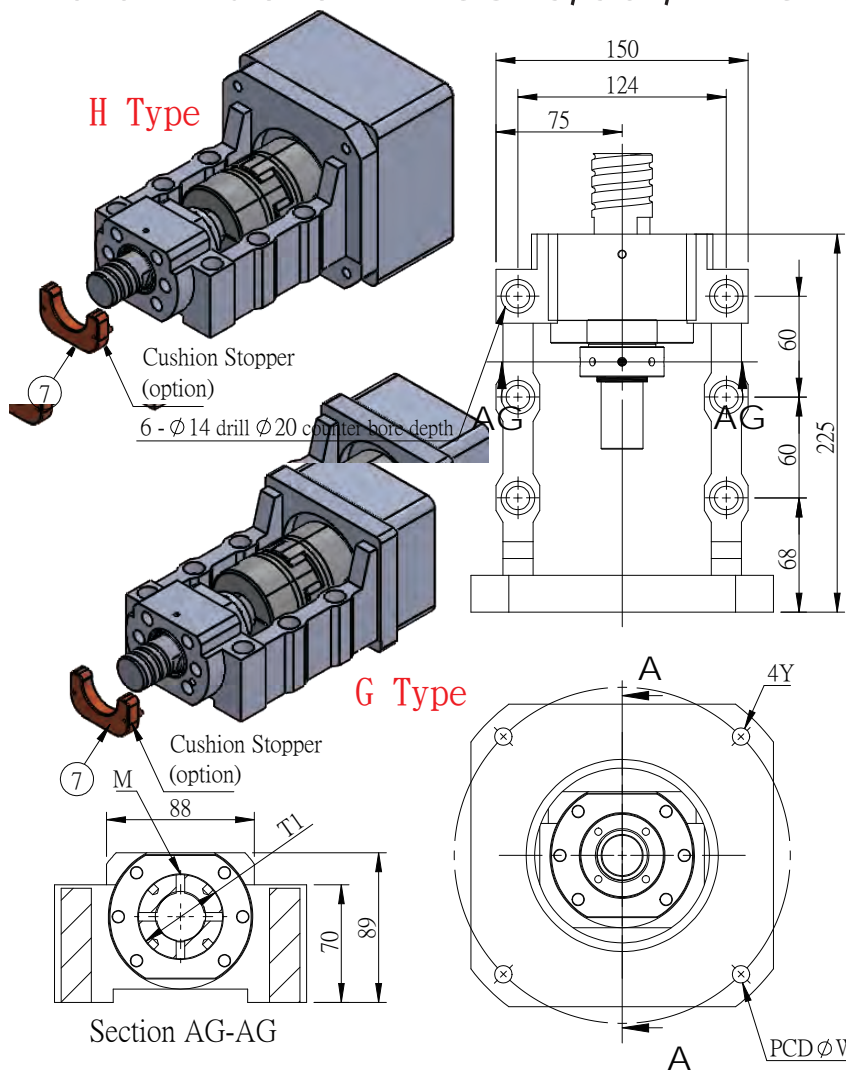

No.	Part name	Qty
1	Housing	1
2	Bearing MBCS25 with bearings 25TAC MBCS30 with bearings 30TAC MBCF30 with bearings 7206	1set
3	Holding lid	1
4	Collar	2
5	Seal	2
6	Lock nut	1set
7	Cushion Stopper (option)	1

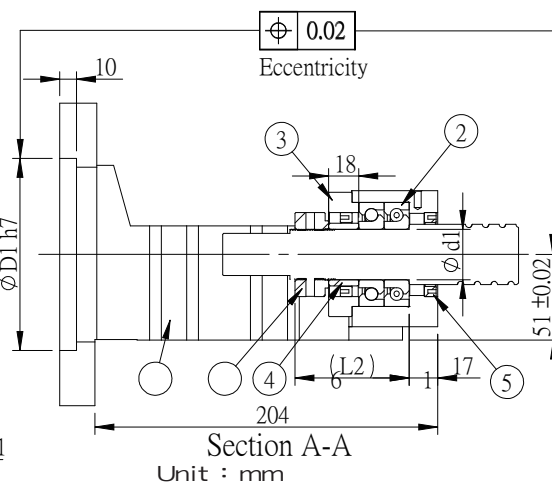

Model No.	D1	W1	Y	Shaft diameter d1	L2	M	T1	Weight (Kgs)	Support unit	Suggest Coupling	
									Supported-side		
MBCS25W-G	110	145	M8	25	68	4-M6	Ø45	-	SBK25/SF25	ROTEX GS38	
※ MBCS25-I	130	165	M10							ROTEX GS28	
※ MBCS25-J	150	185	M10							MTC-65C-RD	
MBCS25-H	114.3	200	M12	30	68	4-M6	Ø50	-	SBK30/BF30	ROTEX GS28	
※ MBCS30W-G	110	145	M8							8.4	ROTEX GS38
※ MBCS30-I	130	165	M10							-	ROTEX GS28
※ MBCS30-J	150	185	M10							10.3	MTC-65C-RD
MBCS30-H	114.3	200	M12	30	70	4-M6	Ø50	-	BK30/BF30	ROTEX GS28	
※ MBCF30W-G	110	145	M8							ROTEX GS38	
※ MBCF30-I	130	165	M10							ROTEX GS28	
※ MBCF30-J	150	185	M10							MTC-65C-RD	
MBCF30-H	114.3	200	M12	-	-	-	-	-	-	ROTEX GS28	

※Customized.

Note : 1. The matched bearing in the support unit has already done the preload.

2. The matched bearings are assembled in DF way, which is the most suitable for ball screw use.

3. The accuracy of TAC bearing is P4 grade and 7206 is P5 grade.

Illustration for MBC30

Fixed+Fixed

Pattern : Servo motor
 YASKAWA SGMGH-05
 MITSUBISHI HF-SP51-81/HF-SP52-152
 DELTA G11303
 □ 130x130

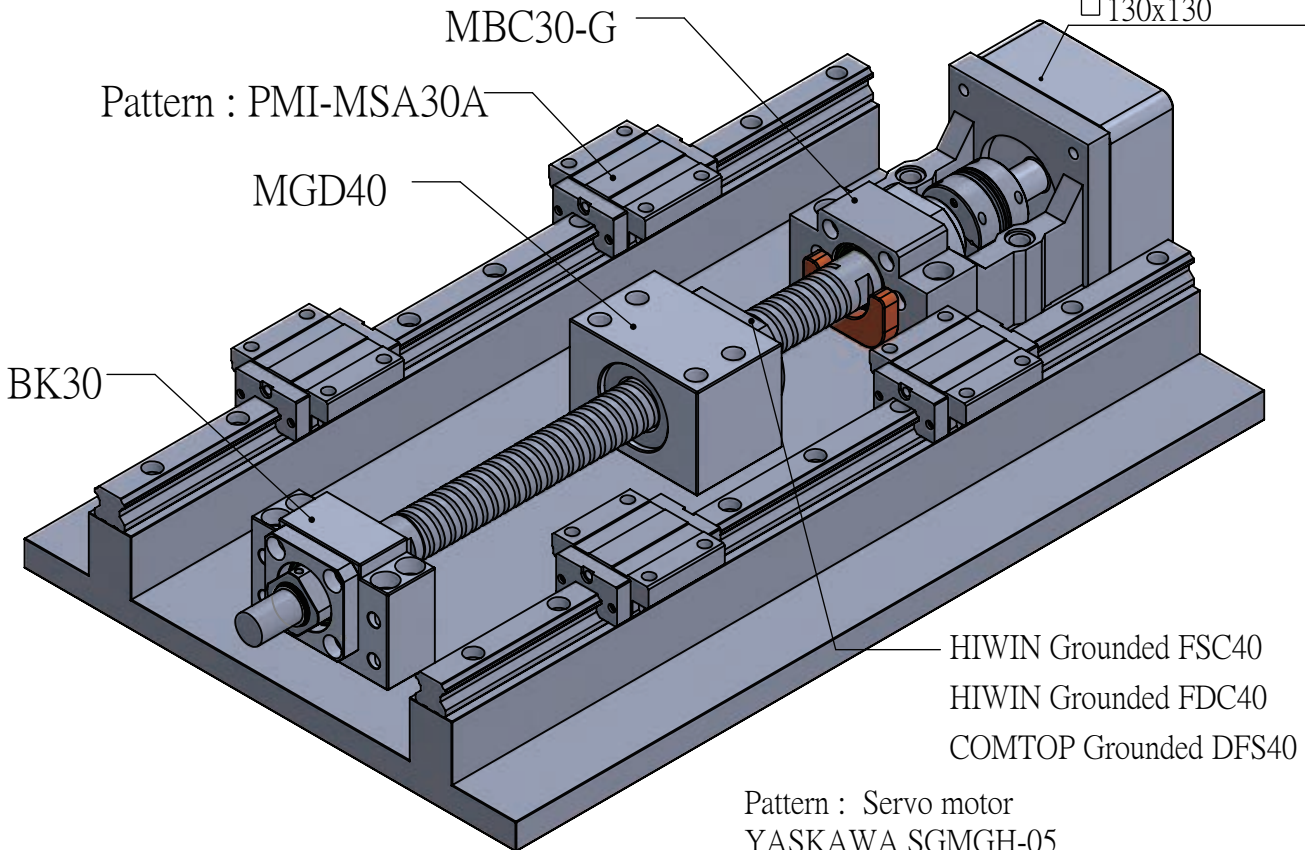

Fixed+Supported

Pattern : Servo motor
 YASKAWA SGMGH-05
 MITSUBISHI HF-SP51-81
 HF-SP52-152
 DELTA G11303
 □ 130x130

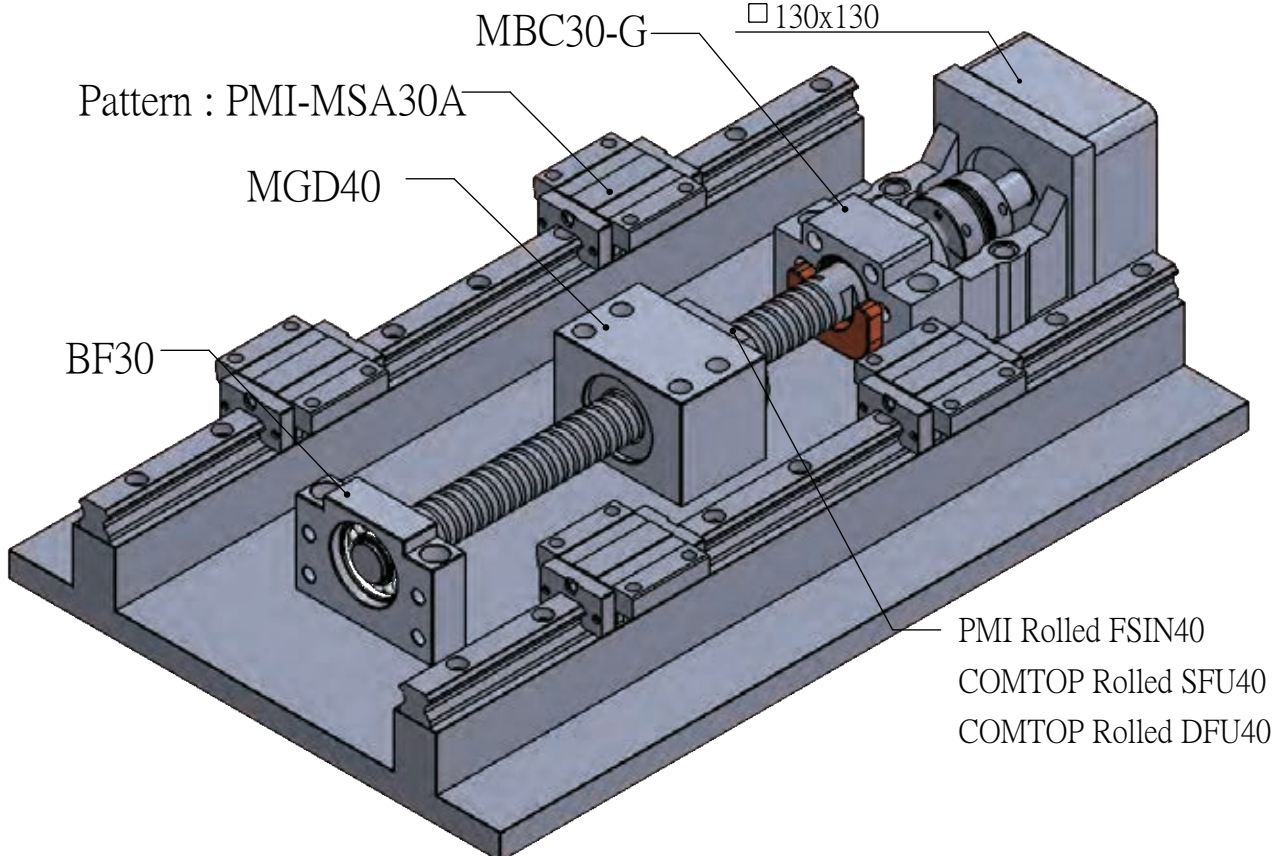



Motor Bracket MBCK25/30/35/40

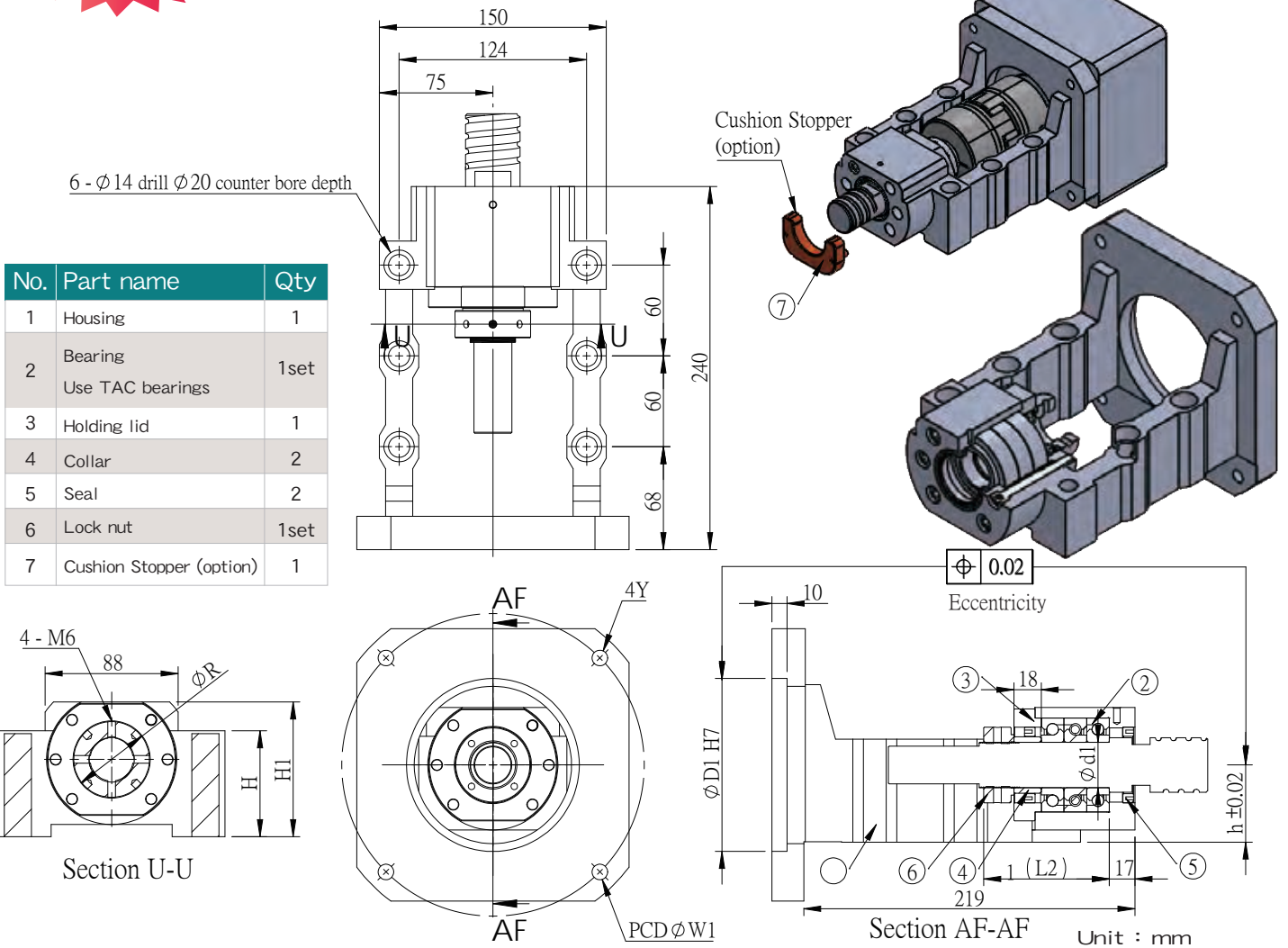

No.	Part name	Qty
1	Housing	1
2	Bearing Use TAC bearings	1set
3	Holding lid	1
4	Collar	2
5	Seal	2
6	Lock nut	1set
7	Cushion Stopper (option)	1

Section U-U

Section AF-AF Unit : mm

Model No.	D1	W1	Y	h ±0.02	Shaft diameter d1	L2	R	H	H1	Weight (Kgs)	Support unit	Suggest Coupling
											Supported-side	
MBCK25-G	110	145	M8	51	25	83	Ø45	70	89	-	SBK25/SF25	ROTEX GS38
※ MBCK25-I	130	165	M10									ROTEX GS28
※ MBCK25-J	150	185	M10									MTC-65C-RD
MBCK25-H	114.3	200	M12									ROTEX GS28
MBCK30-G	110	145	M8	51	30	83	Ø50	70	89	-	SBK30/BF30	MTC-65C-RD
※ MBCK30-I	130	165	M10									ROTEX GS28
※ MBCK30-J	150	185	M10									ROTEX GS38
MBCK30-H	114.3	200	M12									MTC-65C-RD
MBCK35-G	110	145	M8	52	35	85	Ø55	71	96	-	SBK35/BF35	ROTEX GS28
※ MBCK35-I	130	165	M10									ROTEX GS38
※ MBCK35-J	150	185	M10									MTC-65C-RD
MBCK35-H	114.3	200	M12									ROTEX GS28
MBCK40-G	110	145	M8	52	40	85	Ø60	71	96	-	SBK40/SF40	MTC-65C-RD
※ MBCK40-I	130	165	M10									ROTEX GS28
※ MBCK40-J	150	185	M10									ROTEX GS38
MBCK40-H	114.3	200	M12									MTC-65C-RD

※Customized ◦

Note :1. The matched bearing in the support unit has already done the preload.

2. The matched P5 bearings are assembled in DFD way, which is the most suitable for ball screw use.

Motor Bracket MBCS35/40

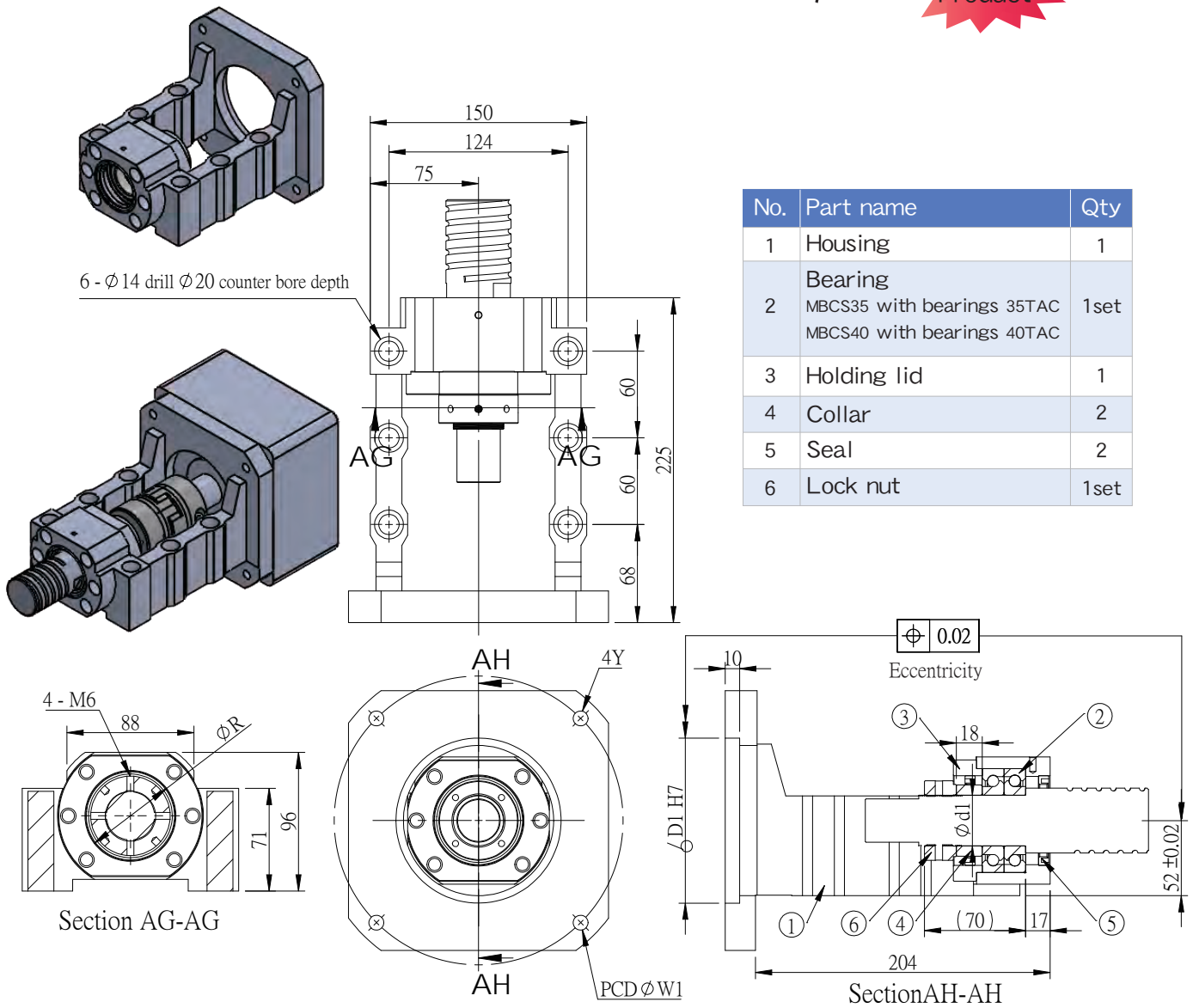

Unit : mm

	Model No.	D1	W1	Y	Shaft diameter d1	R	Weight (Kgs)	Support unit	Suggest Coupling
								Supported-side	
※	MBCS35-G	110	145	M8	35	Ø55	-	SBK35 BF35	ROTEX GS38 ROTEX GS28 MTC-65C-RD
※	MBCS35-I	130	165	M10					
※	MBCS35-J	150	185	M10					
	MBCS35-H	114.3	200	M12					ROTEX GS28 MTC-65C-RD
※	MBCS40-G	110	145	M8	40	Ø60	8.5	SBK40 SF40	ROTEX GS38 ROTEX GS28 MTC-65C-RD
※	MBCS40-I	130	165	M10					
※	MBCS40-J	150	185	M10					
	MBCS40-H	114.3	200	M12					

※Customized.

Note :1. The matched bearing in the support unit has already done the preload.

2. The matched P5 bearings are assembled in DF way, which is the most suitable for ball screw use.

Recommended shaft end shape (Fixed-side)

for MBC types

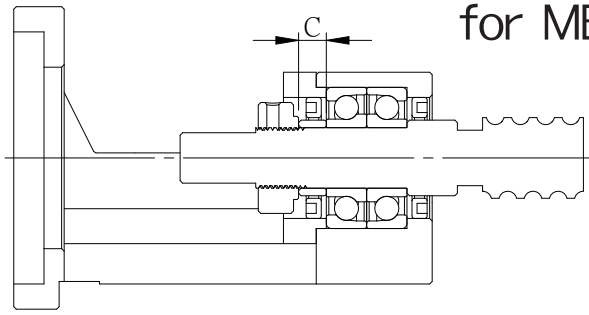

Ground Ballscrew

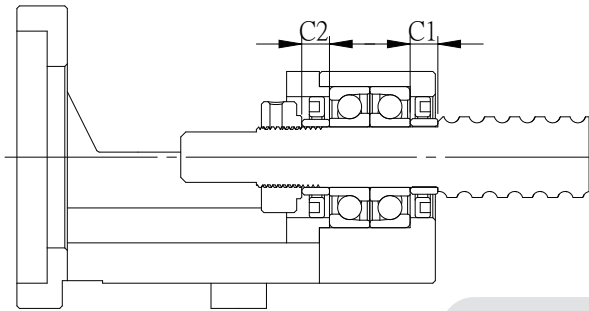
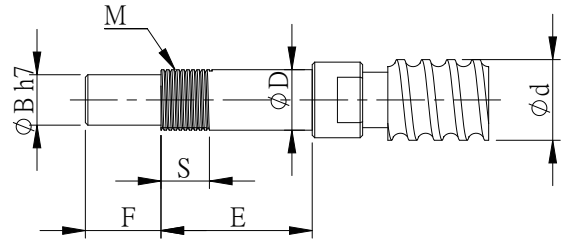

Rolled Ballscrew

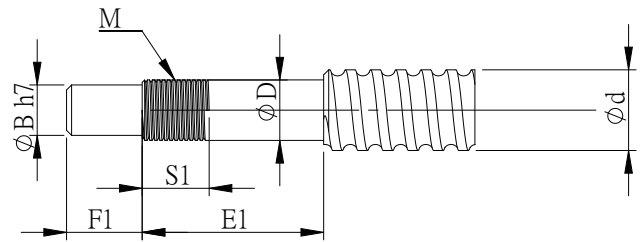

Unit : mm

Model No.	Ballscrew shaft OD	Shaft support portion OD	Shaft dimensions				Metric screw thread			Length of Sleeve					
			B	E	E1	F	F1	M	S	S1	C	C1	C2		
MBC types	d	D	B	E	E1	F	F1	M	S	S1	C	C1	C2		
MBCE10 MBCF10	12/14/15	10 ^{-0.005} ^{-0.015}	8	30	36	15		M10X1	10	12	5.5	5.5			
MBCB12	14/15/16	12 ^{-0.005} ^{-0.017}	10	30	36	15		M12X1	10	12	5.5	5.5			
MBCE12 MBCF12															
MBCB15	18/20	15 ^{-0.005} ^{-0.017}	12	40	40	20		M15X1	15	12	10	6	6		
MBCB15M													10	10	
MBCE15														10	
MBCE15M														6	10
MBCA15														6	
MBCS15				53	62	25			16		9				
MBCS17	20/25	17 ^{-0.005} ^{-0.017}	15	60	69	19		M17X1		23		9			
MBCF20	25/28	20 ^{-0.006} ^{-0.017}	17	53	64	27		M20X1		16		11			
MBCS20					60	69	25				23	9			
MBCA20					43	51	22				16	8			
MBC25	30/32/36	25 ^{-0.006} ^{-0.017}	20	62	76	33	30	M25X1.5		20		14			
MBCS25					67	82	27				26	15			
MBCF30	36/40	30 ^{-0.010} ^{-0.020}	25	64	73	30		M30X1.5		25		9			
MBCS30					67	82	27				26	15			

Recommended shaft end shape (Fixed-side) for MBC (Long Type)

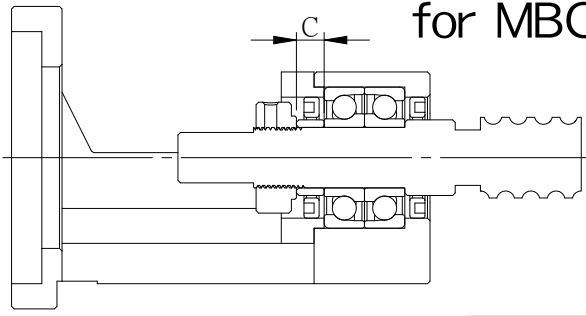

Ground Ballscrew

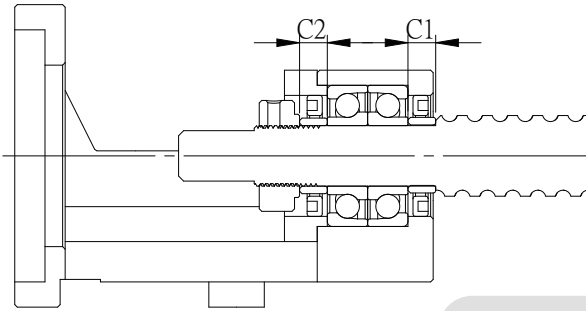
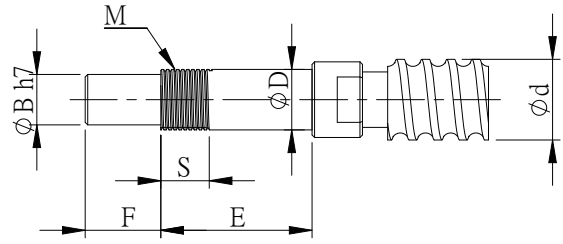

Rolled Ballscrew

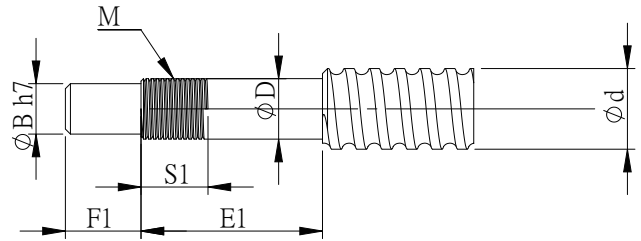

Unit : mm

Model No.	Ballscrew shaft OD	Shaft support portion OD	Ground Ballscrew					Metric screw thread			Length of Sleeve												
			B	E	E1	F	F1	M	S	S1	C	C1	C2										
MBC型	d	D																					
MBCS25W-G	30/32/36	25 ^{-0.005} -0.020	20	71	89	60	M25x1.5	26	18	C	C1	C2											
MBCS25-I						60																	
MBCS25-J						58																	
MBCS25-H						40																	
MBCK25-G						60																	
MBCK25-I						60																	
MBCK25-J						58																	
MBCK25-H						40																	
MBCS30W-G						36/40							30 ^{-0.005} -0.020	25	71	89	60	M30x1.5	26	18	C	C1	C2
MBCS30-I																	60						
MBCS30-J	58																						
MBCS30-H	40																						
MBCF30W-G	60																						
MBCF30-I	60																						
MBCF30-J	58																						
MBCF30-H	40																						
MBCK30-G	60																						
MBCK30-I	60																						
MBCK30-J	58																						
MBCK30-H	40																						
MBCS35-G	45	35 ^{-0.006} -0.025	30	74	92	57	M35x1.5	30	18	C	C1	C2											
MBCS35-I						57																	
MBCS35-J						55																	
MBCS35-H						37																	
MBCK35-G						57																	
MBCK35-I						57																	
MBCK35-J						55																	
MBCK35-H						37																	
MBCS40-G						50							40 ^{-0.006} -0.025	35	74	92	57	M40x1.5	30	18	C	C1	C2
MBCS40-I																	57						
MBCS40-J	55																						
MBCS40-H	37																						
MBCK40-G	57																						
MBCK40-I	57																						
MBCK40-J	55																						
MBCK40-H	37																						

Motor Bracket MBA (Narrow Type)

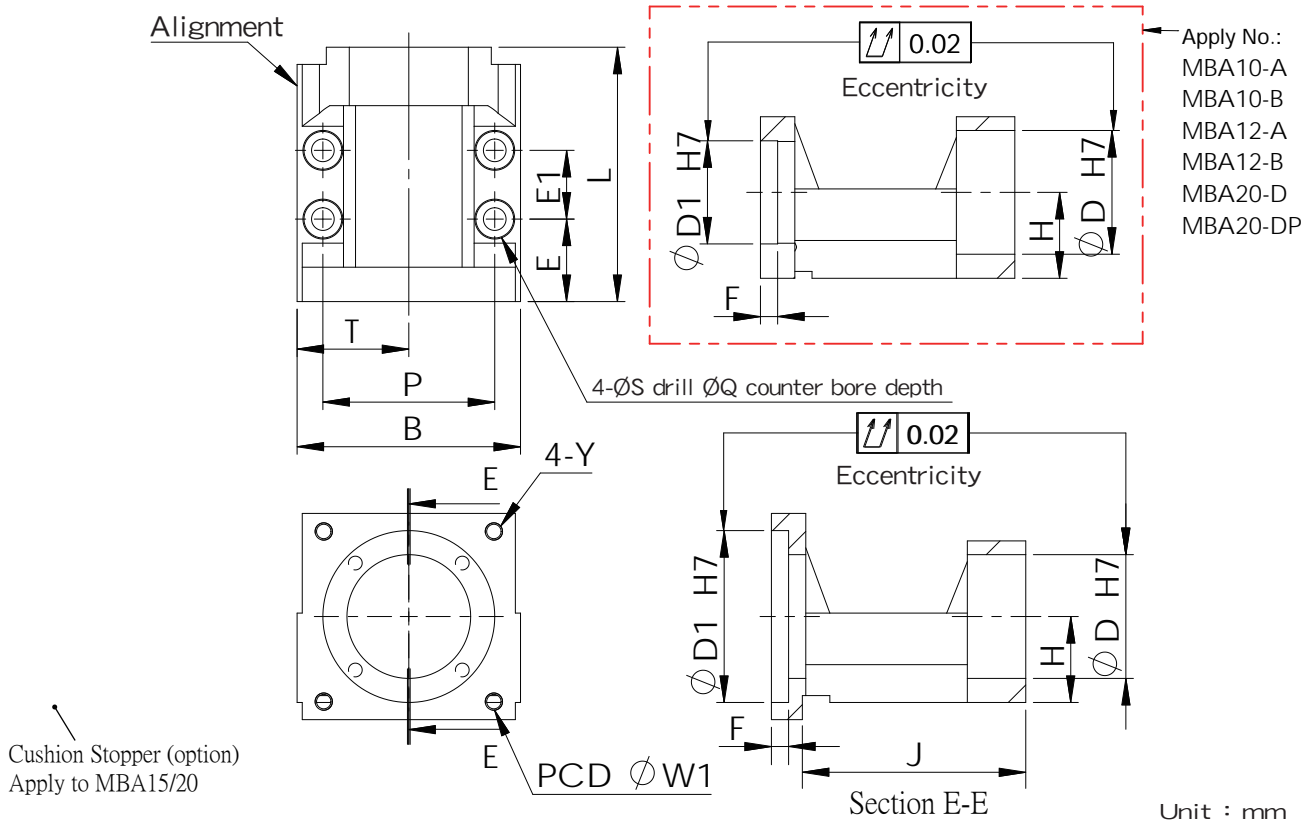

Model No.	Dimensions of Motor Bracket															Support unit		Suggest Coupling	
	D1	W1	Y	D	L	H ±0.02	B	P	T	S	Q	E	E1	F	J	Weight (Kgs)	Fixed-side		Supported-side
MBA6/8-A	30	45	M3	28	61	17	52	41	26	5.5	9.5	19	20	5	54	0.29	FKA06 FKA08	EF08	SGS 27C
MBA6/8-B		46	M4																
MBA10-A	30	45	M3	34	74	22	65	50	32.5	6.6	11	24	20	5	flat	0.62	FK10	BF10	SGL 27C
MBA10-B		46	M4																
MBA10-C	38.1	66.7	M4	34	74	22	65	50	32.5	6.6	11	24	20	5	65	0.66	FK10	BF10	SGL 34C
MBA10-D	50	70																	
MBA10-DP			M4	0.63															
MBA12-A	30	45	M3		36	74	25	65	50	32.5	6.6	11	24	20	5	flat	0.67	FK12	BF12
MBA12-B		46	M4	0.68															
MBA12-BF	36	70.7	M4		36	74	25	65	50	32.5	6.6	11	24	20	Thru hole	65	0.67	FK12	BF12
MBA12-C	38.1	66.7		0.69															
MBA12-D	50	70	M5		36	74	25	65	50	32.5	6.6	11	24	20	5	65	0.67	FK12	BF12
MBA12-DP			M4	0.66															
MBA15-C	38.1	66.7	M4		40	84	28	70	55	35	6.6	11	25	28	5	75	0.81	FK15	BF15
MBA15-D	50	70	M5	0.81															
MBA15-DP			M4		0.79														
MBA15-F	73	98.4	M6	40		94	28	88	70	44	8.5	14	30	6	83	1.3	FK15	BF15	SGS 40C
MBA15-E	70	90			1.3														
MBA15-EP			M5	1.32															
MBA20-D	50	70	M5		57	113	34	88	70	44	8.5	14	29	42	5	flat	1.54	FKA20	BF20
MBA20-DP			M4	1.56															
MBA20-F	73	98.4	M6		57	113	34	88	70	44	8.5	14	29	42	6	102	1.57	FKA20	BF20
MBA20-E	70	90		1.59															
MBA20-EP			M5		1.6														
MBA20-X	80	100	M6	57		113	34	88	70	44	8.5	14	29	42	6	102	1.54	FKA20	BF20

Note : 1.Can choose B angle bearings when use support unit with FKA20

Motor Bracket MBB (Hidden Type)

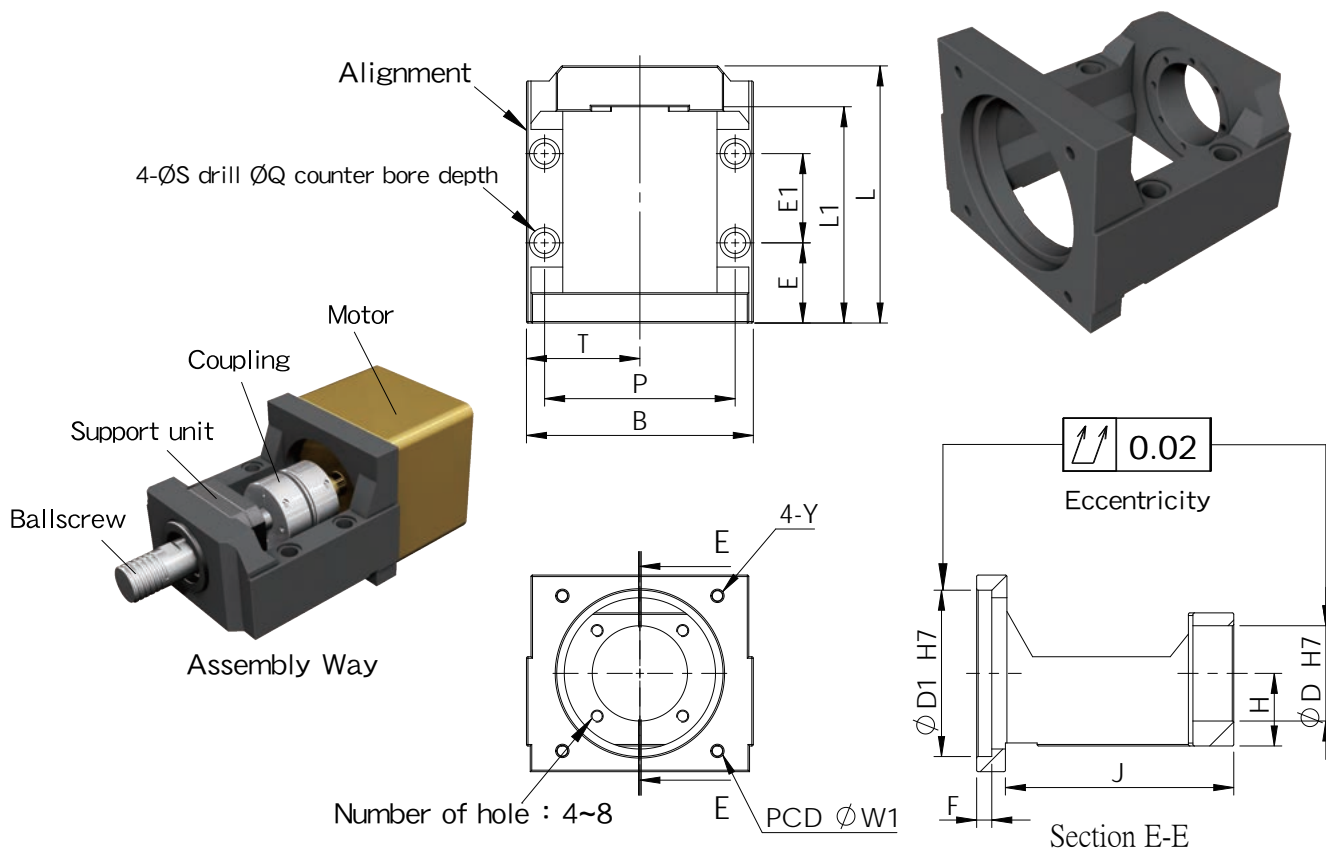

Unit : mm

Model No.	Dimensions of Motor Bracket															Support unit		Suggest Coupling			
	D1	W1	Y	D	L	L1	H ±0.02	B	P	T	S	Q	E	E1	F	J	Weight (Kgs)		Fixed-side	Supported-side	
MBB20L-G				57														FK20B	BF20H	SGL 65C	
MBB20-G	110	145	M8	58	170	143	48	150	126	75	14	20	53	59	10	151	5.61	MBK15DF MBK17DF MBK20DF	BF15+20mm BF17+9mm BF20H		
MBB25L-S		130			168	141							51	59	8	146	5.94	FK25	BF25		SGL 65C SGS 65C
MBB25L-G	110	145	M8	63	170	143	48	150	126	75	14	20	53	70	10	151	5.47				
MBB25L-G-M													55	70	10	151	6.05				
MBB30-H	114.3	200	M12	85	230	189	51	200	170	100	18	26	75	75	Thru hole	201	11.02	WBK25DF WBK25DFD WBK30DF WBK30DFD	SF25 SBK25 BF30 SBK30	SAP-82C SAP-94C	
※ MBB30-I	130	165	M10	85	230	189	51	200	170	100	18	26	75	75		10	201	11.15	WBK25DF WBK25DFD	SF25 SBK25	SAP-82C SAP-94C
※ MBB30-J	150	185													11.1			WBK30DF WBK30DFD	BF30 SBK30		

※Customized ◦

Note : 1.Can choose B angle bearings when use support unit with FK20/FK25

Motor Bracket MBL (Low Narrow Type)

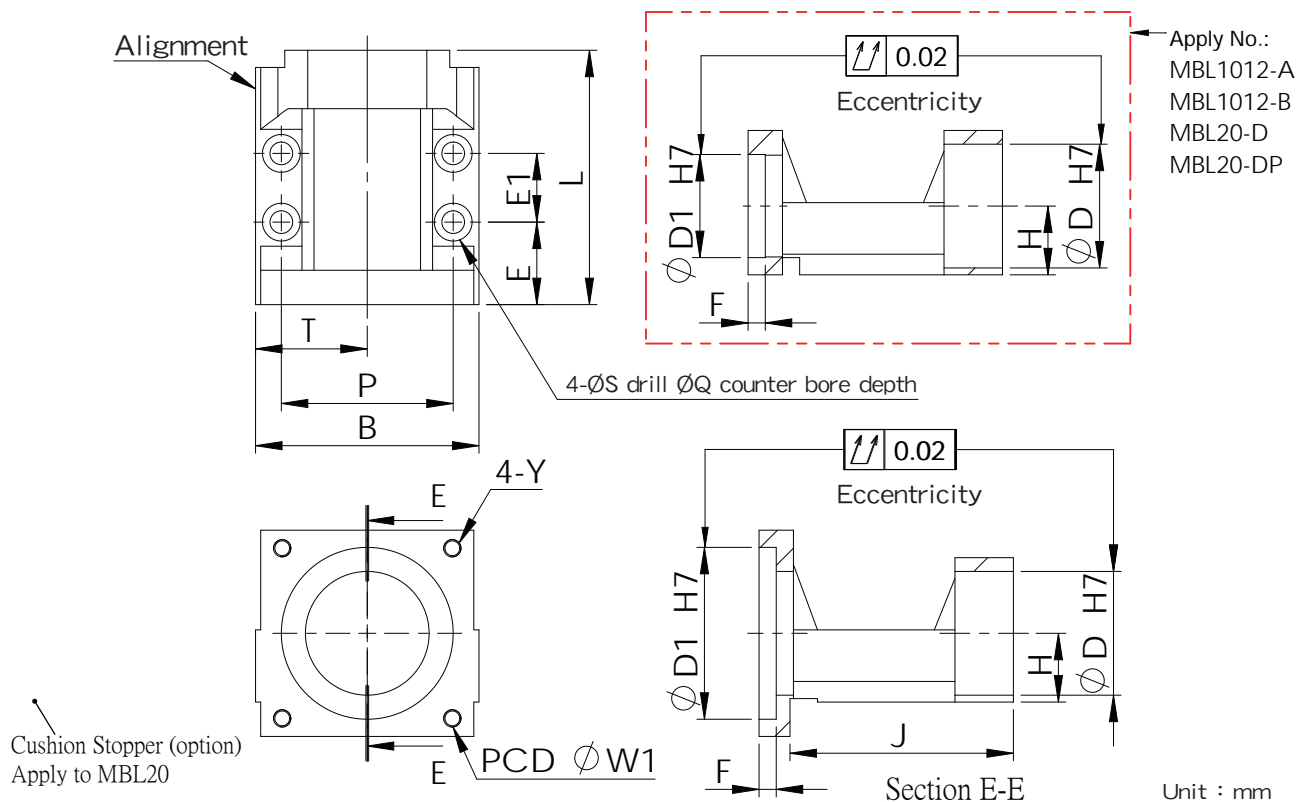

Model No.	Dimensions of Motor Bracket																Support unit		Suggest Coupling
	D1	W1	Y	D	L	H ±0.02	B	P	T	S	Q	E	E1	F	J	Weight (Kgs)	Fixed-side	Supported-side	
MBL6/8-A	30	45	M3	28	61	15.5	52	41	26	5.5	9.5	19	20	5	54	0.27	FKA06	LF08	SGS 27C
MBL6/8-B		46	M4														FKA08	LFA12	
MBL10/12-A	30	45	M3	36	74	20	65	50	32.5	6.6	11	24	20	5	flat	0.57	FKA10	LF12	SGS 27C
MBL10/12-B		46	M4																
MBL10/12-C	38.1	66.7	M4	40	74	22	65	50	32.5	6.6	11	24	20	5	65	0.62	FKA10	LF12	SGS 34C
MBL10/12-D	50	70	M5																
MBL10/12-DP			50	70	M4	40	74	22	65	50	32.5	6.6	11	24	20	5	65	0.59	FKA10
MBL15-C	38.1	66.7			M4														
MBL15-D	50	70	M5	40	84	22	70	55	35	6.6	11	25	28	5	75	0.69	FKA15	LF15	SGS 34C
MBL15-DP			M4																
MBL15-F	73	98.4	M6	40	92	22	88	70	44	8.5	14	30	28	6	82	1.22	FKA15	LF15	SGS 40C
MBL15-E	70	90	M5																
MBL15-EP			70	90	M5	40	92	22	88	70	44	8.5	14	30	28	6	81	1.17	FKA15
MBL20-D	50	70			M5														
MBL20-DP	50	70	M4	40	84	22	70	55	35	6.6	11	25	28	5	75	0.69	FKA15	LF15	SGS 34C
MBL20-F			73																
MBL20-E	70	90	M5	40	92	22	88	70	44	8.5	14	30	28	6	82	1.22	FKA15	LF15	SGS 40C
MBL20-EP			M5																
MBL20-X	80	100	M6	40	92	22	88	70	44	8.5	14	30	28	6	102	1.49	FKA20	LFA25	SGS 45C
MBL20-D	50	70	M5																
MBL20-DP	50	70	M4	40	84	22	70	55	35	6.6	11	25	28	5	75	0.69	FKA15	LF15	SGS 34C
MBL20-F			73																
MBL20-E	70	90	M5	40	92	22	88	70	44	8.5	14	30	28	6	82	1.22	FKA15	LF15	SGS 40C
MBL20-EP			M5																
MBL20-X	80	100	M6	40	92	22	88	70	44	8.5	14	30	28	6	102	1.49	FKA20	LFA25	SGS 45C
MBL20-D	50	70	M5																
MBL20-DP	50	70	M4	40	84	22	70	55	35	6.6	11	25	28	5	75	0.69	FKA15	LF15	SGS 34C
MBL20-F			73																
MBL20-E	70	90	M5	40	92	22	88	70	44	8.5	14	30	28	6	82	1.22	FKA15	LF15	SGS 40C
MBL20-EP			M5																
MBL20-X	80	100	M6	40	92	22	88	70	44	8.5	14	30	28	6	102	1.49	FKA20	LFA25	SGS 45C
MBL20-D	50	70	M5																
MBL20-DP	50	70	M4	40	84	22	70	55	35	6.6	11	25	28	5	75	0.69	FKA15	LF15	SGS 34C
MBL20-F			73																
MBL20-E	70	90	M5	40	92	22	88	70	44	8.5	14	30	28	6	82	1.22	FKA15	LF15	SGS 40C
MBL20-EP			M5																
MBL20-X	80	100	M6	40	92	22	88	70	44	8.5	14	30	28	6	102	1.49	FKA20	LFA25	SGS 45C
MBL20-D	50	70	M5																
MBL20-DP	50	70	M4	40	84	22	70	55	35	6.6	11	25	28	5	75	0.69	FKA15	LF15	SGS 34C
MBL20-F			73																
MBL20-E	70	90	M5	40	92	22	88	70	44	8.5	14	30	28	6	82	1.22	FKA15	LF15	SGS 40C
MBL20-EP			M5																
MBL20-X	80	100	M6	40	92	22	88	70	44	8.5	14	30	28	6	102	1.49	FKA20	LFA25	SGS 45C
MBL20-D	50	70	M5																
MBL20-DP	50	70	M4	40	84	22	70	55	35	6.6	11	25	28	5	75	0.69	FKA15	LF15	SGS 34C
MBL20-F			73																
MBL20-E	70	90	M5	40	92	22	88	70	44	8.5	14	30	28	6	82	1.22	FKA15	LF15	SGS 40C
MBL20-EP			M5																
MBL20-X	80	100	M6	40	92	22	88	70	44	8.5	14	30	28	6	102	1.49	FKA20	LFA25	SGS 45C
MBL20-D	50	70	M5																
MBL20-DP	50	70	M4	40	84	22	70	55	35	6.6	11	25	28	5	75	0.69	FKA15	LF15	SGS 34C
MBL20-F			73																
MBL20-E	70	90	M5	40	92	22	88	70	44	8.5	14	30	28	6	82	1.22	FKA15	LF15	SGS 40C
MBL20-EP			M5																
MBL20-X	80	100	M6	40	92	22	88	70	44	8.5	14	30	28	6	102	1.49	FKA20	LFA25	SGS 45C
MBL20-D	50	70	M5																
MBL20-DP	50	70	M4	40	84	22	70	55	35	6.6	11	25	28	5	75	0.69	FKA15	LF15	SGS 34C
MBL20-F			73																
MBL20-E	70	90	M5	40	92	22	88	70	44	8.5	14	30	28	6	82	1.22	FKA15	LF15	SGS 40C
MBL20-EP			M5																
MBL20-X	80	100	M6	40	92	22	88	70	44	8.5	14	30	28	6	102	1.49	FKA20	LFA25	SGS 45C
MBL20-D	50	70	M5																
MBL20-DP	50	70	M4	40	84	22	70	55	35	6.6	11	25	28	5	75	0.69	FKA15	LF15	SGS 34C
MBL20-F			73																
MBL20-E	70	90	M5	40	92	22	88	70	44	8.5	14	30	28	6	82	1.22	FKA15	LF15	SGS 40C
MBL20-EP			M5																
MBL20-X	80	100	M6	40	92	22	88	70	44	8.5	14	30	28	6	102	1.49	FKA20	LFA25	SGS 45C
MBL20-D	50	70	M5																
MBL20-DP	50	70	M4	40	84	22	70	55	35	6.6	11	25	28	5	75	0.69	FKA15	LF15	SGS 34C
MBL20-F			73																
MBL20-E	70	90	M5	40	92	22	88	70	44	8.5	14	30	28	6	82	1.22			

Motor Bracket MBH

Pattern:MBH15-EP

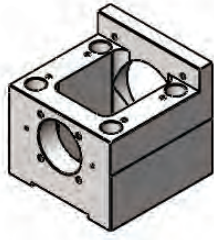

Pattern:MBH15-D

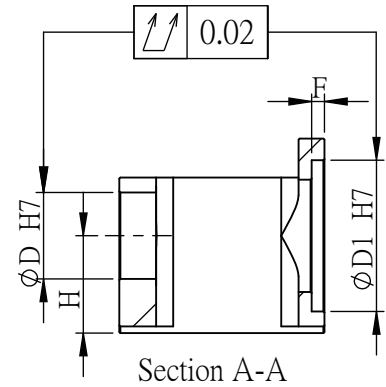
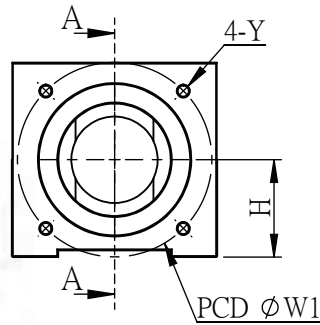
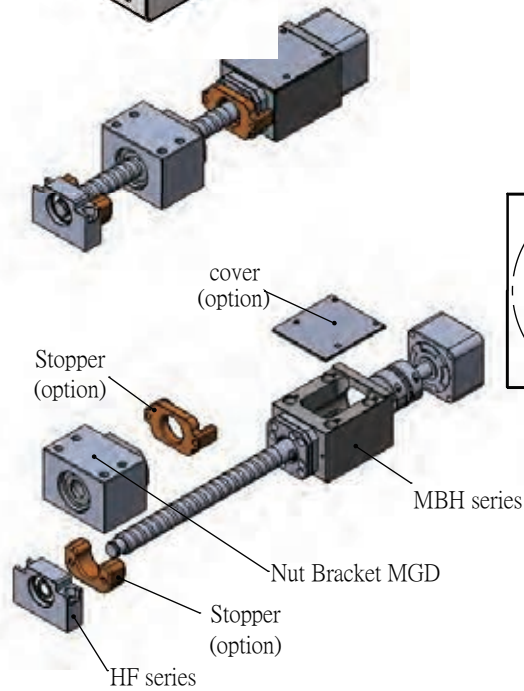
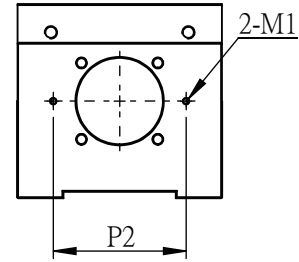
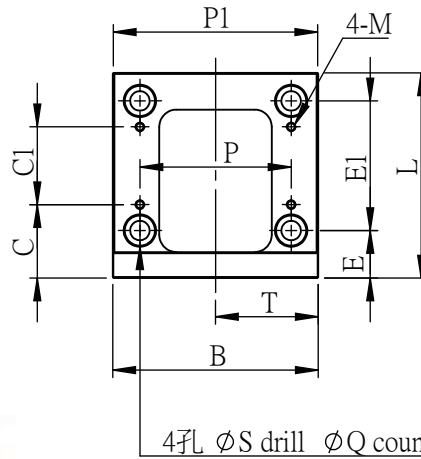
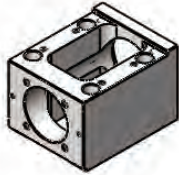

Unit : mm

Model No.	D1	W1	Y	L	D	H ± 0.02	B	T	P	S	Q	E
MBH15-D	50	70	M5	88	40	30	70	35	54	6.6	11	23
MBH15-DP			M4									
MBH15-E	70	90	M6	95	40	45	95	47.5	70	9	14	22
MBH15-EP			M5									
MBH15H-EP			50									

Model No.	E1	P1	M	C	C1	M1	P2	F	Weight (Kgs)	Support unit		Suggest Coupling							
										Fixed-side	Supported-side								
MBH15-D	50	-	M4	33	30	M3	61.5	5	1.14	FK 15	HF 15	SGS 34C SGS 40C							
MBH15-DP													1.13						
MBH15-E	60	94.6	M4	34	36	M3	61.5	6	2.4	FK 15	HF 15H	SGS 45C SGS 50C							
MBH15-EP									2.42										
MBH15H-EP									-	-		-	-	-	-	-	-	FKA15H FKA 20L	SGS 50C

Motor Bracket MB and Corresponding motor reference table

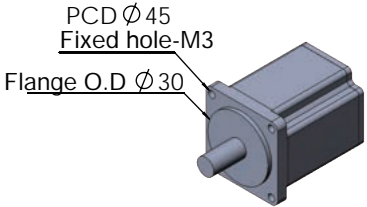
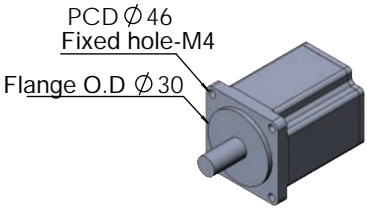
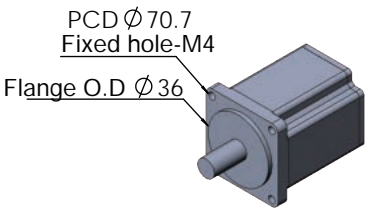
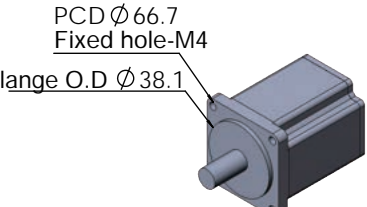
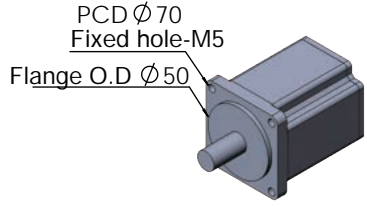
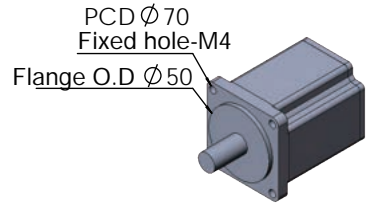
Motor Bracket	Servo Motor Brand Specification		
	Manufacturer	Model No.	Flange Width
MB*-A 	Panasonic	MSMA3A MSMA5A MSMA01	38
	HIWIN	FRLS50W/100W	
MB*-B 	Yaskawa electric	SGMAH-A3 SGMAH-A5	40
	Mitsubishi electric	HF-KP053 / 13 HF-MP053 /13	
	OMRON	R88M-W03030 R88M-W05030 R88M-W10030	
	SANYO	P30B04003 P30B04005 P30B04010	
MB*-BF 	Oriental motor	ARM69AC	60
MB*-C 	Yaskawa electric	02SGMAH-21 04SGMAH-21	60
MB*-D 	Yaskawa electric	SGMAH-02 / 04A SGMAH-03D	60
	Mitsubishi electric	HF-KP23 / 43 HF-MP23 /43	
	OMRON	R88M-W20030 R88M-W40030	
	SANYO	P30B06020 P30B06040	
	DELTA	C10602 C10604	
	HIWIN	FRLS200W FRLS400W	
MB*-DP 	Panasonic	MSMA021 MSMA041	60

Note :

1.Please notice the length of motor shaft.

2.Specifications are subject to change without prior notice if required to improve performance °

Motor Bracket MB and Corresponding motor reference table

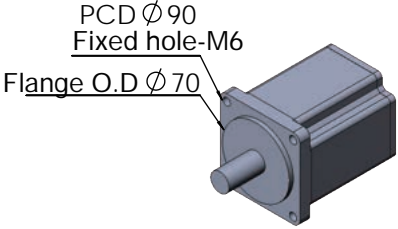
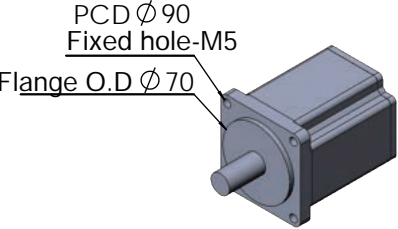
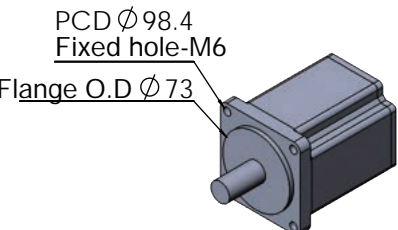
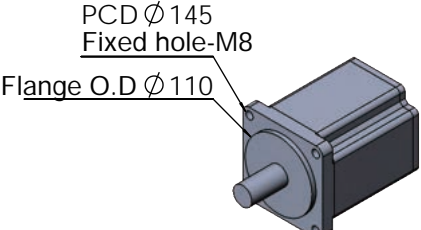
Motor Bracket	Servo Motor Brand Specification		
	Manufacturer	Model No.	Flange Width
MB*-E 	Yaskawa electric	SGMAH-08A	80
	Mitsubishi electric	HF-KP73 HF-MP73	
	SANYO	P30B08075	
	DELTA	C10807	
	HIWIN	FRMS750W	
MB*-EP 	Panasonic	MSMA082	80
MB*-F 	Yaskawa electric	SGMAH-N21	85
MB*-G 	Yaskawa electric	SGMGH-05 SGMGH-09 SGMGH-13	120~130
	Mitsubishi electric	HF-SP51~81 HF-SP52~152 HF-SP524~1524 HC-LP52~152	
	DELTA	E11305 · G11303 E11310 · G11306 E11315 · G11309 E11320	
	Panasonic	MDMA102 MDMA152 MDMA202 MDMA252 MDMA302	130
	FANUC	B8 · B12	
	HIWIN	FRMM1KW	

Note :

1. Please notice the length of motor shaft.
2. Specifications are subject to change without prior notice if required to improve performance ◦

Motor Bracket MB and Corresponding motor reference table

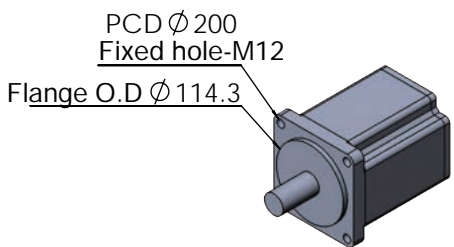
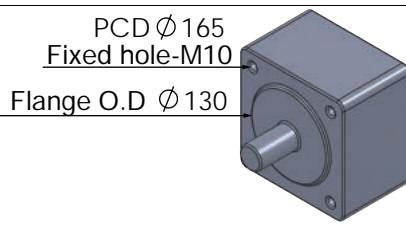
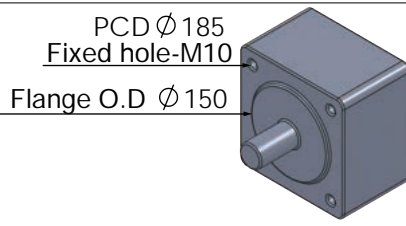
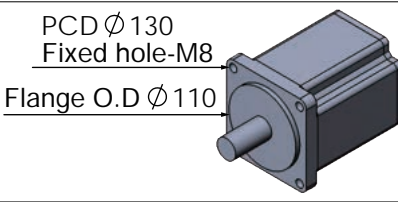
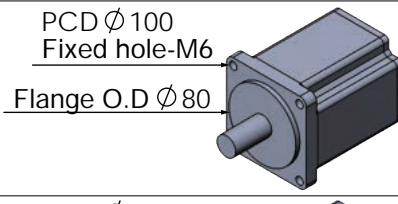
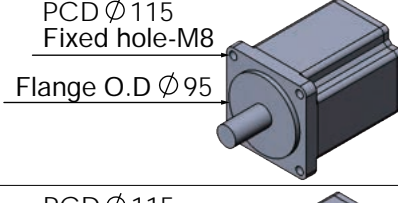
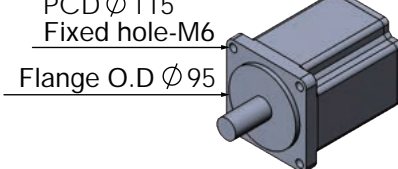
Motor Bracket	Servo Motor Brand Specification		
	Manufacturer	Model No.	Flange Width
MB*-H 	Yaskawa electric	SGMGH-20 SGMGH-30 SGMGH-44	180
	DELTA	E11820 E11830 F11830	
	Mitsubishi electric	HF-SP121~421 HF-SP202~702 HF-SP2024 HF-SP3524 HF-SP5024 HF-SP7024 HC-LP202 HC-LP302	176
	Panasonic	MDMA452 MDMA502	
MB*-I 	SIEMENS	1FT708 1FK708	155
	HEIDENHAIN	QSY155	
MB*-J 	SYNTEC	SP-L5.5-12 SP-L5.5-18 SP-L11-18 SP-M5.5-12	178
MB*-S 	SIEMENS	1FK7060 1FT6062	126 116
MB*-X 	FANUC	β 2/4000is β 4/4000is	90
	SIEMENS	1FT6044 1FK7042-5	96
MB*-Y 	DELTA	C11010 C11020	100
	Mitsubishi electric	HC-RP103 /153 HC-RP203	
MB*-YP 	Yaskawa electric	SGMSH-10 SGMSH-15 SGMSH-20	100

Note :

1. Please notice the length of motor shaft.
2. Specifications are subject to change without prior notice if required to improve performance.

Characteristic Values of (Fixed-side) Support Units and Bearing

Applicable Ball screw OD	Fixed-side				Supported-side								
	Basic dynamic load rating Ca (N)	Load limit (N)	Stiffness (N/ μ m)	Bearing code	Applicable model		Applicable model		Bearing code	Radial direction Basic dynamic load rating Cr (N)			
φ 8	2670	1040	32.8	706 A	FK06	EK06	FF06	EF06	606 ZZ	2260			
					FK08	EK08	FF06	EF08	606 ZZ	2260			
φ 10 ~ φ 12	4400	1450	48.9	708 A	LK08		LFA12		6801 ZZ	1920			
					BK10	FK10	BF10	FF10	EF10	AF10	608 ZZ	3300	
φ 10 ~ φ 15	6600	2730	94	7000 A	EK10	AK10	LFA15		6902 ZZ	4350			
					LK10		LF12		6000 ZZ	4550			
φ 14 ~ φ 18	7100	3040	104	7001 A	BK12	FK12	BF12	FF12	LF12	EF12	AF12	6000 ZZ	4550
					EK12	AK12	LFA15		6902 ZZ	4350			
φ 20	7600	3380	113	7002 A	BK15	FK15	BF15	FF15	LF15	EF15	AF15	6002 ZZ	5600
					EK15	AK15	LFA20		6804 ZZ	4000			
φ 25 ~ φ 28	17200	6900	120	7302 A	MBCA15		AF15		6002 ZZ	5600			
					BK17	FK17	BF17	FF17	6203 ZZ	9550			
φ 30 ~ φ 36	12000	5800	139	7203 A	BK20		BF20		6004 ZZ	9400			
					MBCA20		AF20		6204 ZZ	12800			
φ 40	12700	6400	155	7004 A	BK20	FK20	BF20	AF20	6204 ZZ	12800			
					MBCA20		EF20	AF20	FF20				
φ 45	17900	8240	193	7204 A	AK20	FK20	BF20	AF20	6204 ZZ	12800			
					MBCF20		LFA25 (with AK20)		6005 ZZ	10100			
φ 50	20000	7400	210	7204 B	AK20B	FK20B							
					BK25	FK25	BF25	FF25	AF25				
φ 30 ~ φ 36	20200	10000	8900	7205 A	MBC25		BF25	FF25	6205 ZZ	14000			
					BK25B	FK25B	AK25B						
φ 40	23300	8900	210	7206 A	BK30	FK30	BF30	FF30	6206 ZZ	19500			
					BK30B	FK30B							
φ 45	28000	13700	16500	7206 B	BK30	FK30	BF30	FF30	6207 ZZ	25700			
					BK30B	FK30B							
φ 50	30700	12500	7207 B	BK35		BF35		6208 ZZ	29100				
				BK40									

NOTE:

1. IF THE MOUNTING METHOD IS "FIXED SIDE + FIXED SIDE", THE VALUE OF BASIC DYNAMIC LOAD RATE SHOULD BE DOUBLED.

(The value is for reference only. Please refer the catalogue from each bearing company for actual value)

2. ABOVE TABLE IS FOR NSK BEARING.

Characteristic Values of (Heavy-load) Support Units and Bearing

Applicable Ballscrew OD	Fixed-side							Supported-side			
	Basic dynamic load rating C_a (N)	limiting axial load (N)	preload (N)	axial rigidity (N/ μ m)	starting torque (N \cdot cm)	permissible rotational speed (min^{-1})	Bearing code	Applicable mode	Bearing code	Radial Basic dynamic load rating C_r (N)	
φ 20	21900	26600	1000	555	19	7600	15TAC 47C	MBK15DF MBCS15	AF15	6002 ZZ	5600
φ 20~φ 25	23000	26600	1450	630	19	6900	17TAC 47C	WBK17 DF MBK17 DF MBCS17			
	47500	53500	2010	920	32			MBK17 DFF			
φ 25~φ 28	23000	26600	1450	630	19	6900	20TAC 47C	WBK20 DF MBCS20 MBK20 DF	EF20	AF20	12800
	47500	53500	2010	920	32			MBK20 DFF	MBK20 DFF	FF20	
φ 30~φ 36	29900	40500	2280	850	28	5200	25TAC 62C	WBK25 DF SBK25 DF MBCS25	FF25	SF25	14000
	48500	81500	3100	1250	39			WBK25 DFD SBK25 DFD MBCK25			
	48500	81500	4500	1680	49			WBK25 DFF			
	30500	43000	2400	890	29			WBK30 DF SBK30 DF MBCS30	BF30	FF30	
φ 40	50000	86000	3260	1310	39	4900	30TAC 62C	WBK30 DFD SBK30 DFD MBCK30			19500
	50000	86000	4750	1760	51			WBK30 DFF			
	32500	50000	2750	1030	33			WBK35 DF SBK35 DF MBCS35			
φ 45	53000	100000	3740	1500	41	4100	35TAC 72C	WBK35 DFD SBK35 DFD MBCK35			25700
	53000	100000	5490	2060	52			WBK35 DFF			
	33500	52000	2860	1080	34			WBK40 DF SBK40 DF MBCS40			
φ 50	54000	104000	3900	1590	43	4100	40TAC 72C	WBK40 DFD SBK40 DFD MBCK40			29100
	54000	104000	5730	2150	55			WBK40 DFF			

NOTE: 1. THE MAXIMUM STARTING TORQUE VALUE INCLUDES PRE-LOAD OF BEARINGS. (Torque of seals is not included)

2. ALLOWANCE AXIAL LOAD IS 0.7 TIMES OF LOAD LIMIT.

3. ABOVE TABLE IS FOR NSK BEARING.

Support Unit AK
(fixed-side rectangular type)

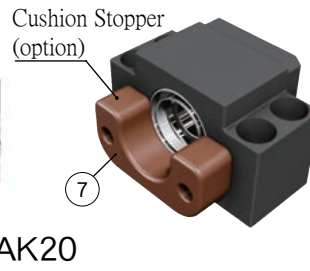

AK

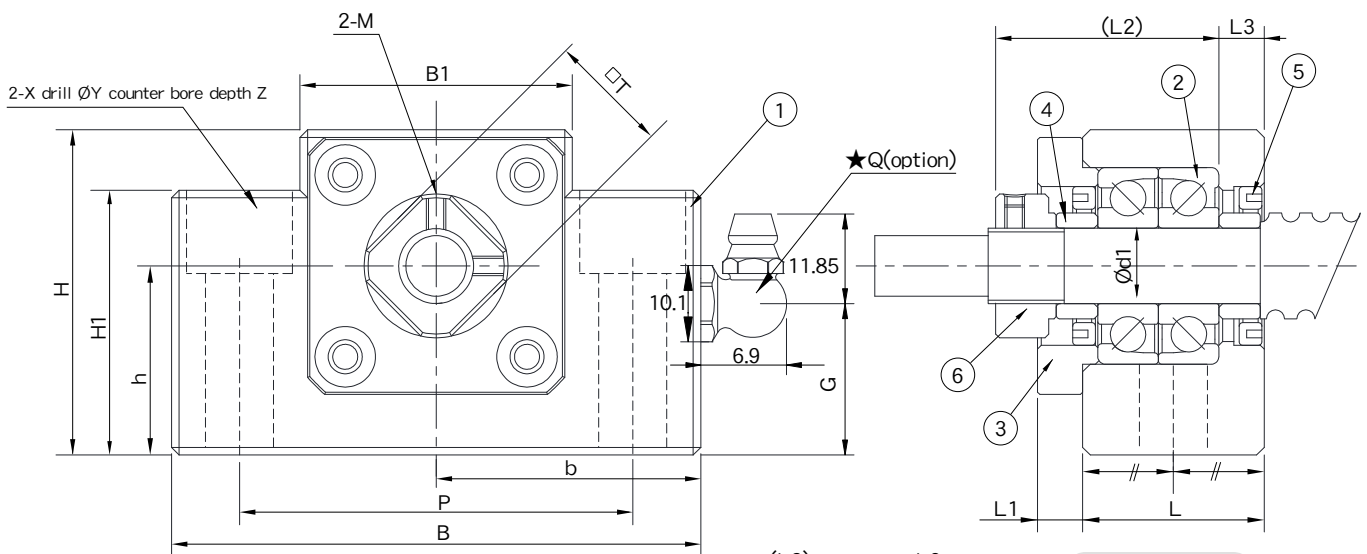

AK10~AK25

AK10~AK15

No.	Part name	Qty
1	Housing	1
2	Bearing	1 set
3	Holding lid	1
4	Collar	2
5	Seal	2
6	Lock nut	1set
7	Cushion Stopper (option)	1

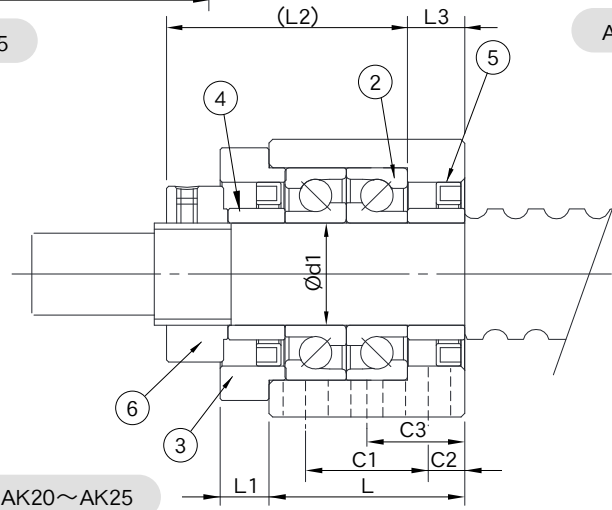

AK20~AK25

Unit : mm

Model No.	Shaft diameter d1	L	L1	L2	L3	B	H	b ± 0.02	h ± 0.02	B1	H1	P	X	Y	Z	M	T	C1	C2	C3	G	Q	Weight (Kgs)
AK10	10	24	6	29.5	6	70	43	35	25	36	35	52	9	14	11	M3	16	-	-	-	20	M6	0.5
AK12	12	24	6	29.5	6	70	43	35	25	36	35	52	9	14	11	M4	19	-	-	-	20	M6	0.49
AK15	15	25	6	36	5	80	50	40	30	41	40	60	11	17	15	M4	22	-	-	-	21	M6	0.64
AK20	20	42	10	50	10	95	58	47.5	30	56	45	75	11	17	15	M4	30	22	10	-	24	M6	1.45
AK25	25	48	12	59	14	105	68	52.5	35	66	25	85	11	-	-	M5	35	30	9	24	58	-	1.94

Support Unit AK (fixed-side rectangular type)

Order Code	Model No.	Surface treatment	Applicable ballscrew accuracy grade	Bearing		Delivery date 	
				Model No.	Max. Starting torque (gf-cm)		
AK10	AK10	Black Oxide	C3 ~ C10	7000A P5	190	EX-STOCK	 <p>★Q option</p> <p>Black Oxide (Application : General case)</p>
AK10_C5			C5 ~ C10	7000A P0	190	EX-STOCK	
AK10_C3			C3	7000A P5	190	EX-STOCK	
AK10_N		Electroless Nickel Plating	C3 ~ C10	7000A P5	190	3 days	
AK10_C5N			C5 ~ C10	7000A P0	190	3 days	
AK10_C3N			C3	7000A P5	190	3 days	
AK12	AK12	Black Oxide	C3 ~ C10	7001A P5	210	EX-STOCK	 <p>★Q option</p> <p>Electroless Nickel Plating (Application : Clean room)</p>
AK12_C5			C5 ~ C10	7001A P0	210	EX-STOCK	
AK12_C3			C3	7001A P5	210	EX-STOCK	
AK12_N		Electroless Nickel Plating	C3 ~ C10	7001A P5	210	EX-STOCK	
AK12_C5N			C5 ~ C10	7001A P0	210	3 days	
AK12_C3N			C3	7001A P5	210	3 days	
AK15	AK15	Black Oxide	C3 ~ C10	7002A P5	230	EX-STOCK	 <p>★Q option</p> <p>Electroless Nickel Plating (Application : Clean room)</p>
AK15_C5			C5 ~ C10	7002A P0	230	EX-STOCK	
AK15_C3			C3	7002A P5	230	EX-STOCK	
AK15_N		Electroless Nickel Plating	C3 ~ C10	7002A P5	230	EX-STOCK	
AK15_C5N			C5 ~ C10	7002A P0	230	3 days	
AK15_C3N			C3	7002A P5	230	3 days	
AK20	AK20	Black Oxide	C3 ~ C10	7204 P5	550	EX-STOCK	 <p>★Q option</p> <p>Black Oxide (Application : General case)</p>
AK20_C5			C5 ~ C10	7204 P0	550	EX-STOCK	
AK20B_C5			C5 ~ C10	7204B P0	550	EX-STOCK	
AK20_C3			C3	7204 P5	550	3 days	
AK20_N		Electroless Nickel Plating	C3~10	7204 P5	550	3 days	 <p>★Q option</p> <p>Electroless Nickel Plating (Application : Clean room)</p>
AK20_C5N			C5 ~ C10	7204 P0	550	3 days	
AK20B_C5N			C5 ~ C10	7204B P0	550	3 days	
AK20_C3N			C3	7204 P5	550	3 days	
AK25	AK25	Black Oxide	C3~10	7205 P5	730	EX-STOCK	 <p>★Q option</p> <p>Black Oxide (Application : General case)</p>
AK25_C5			C5 ~ C10	7205 P0	730	EX-STOCK	
AK25B_C5			C5 ~ C10	7205B P0	730	3 days	
AK25_C3			C3	7205 P5	730	3 days	
AK25_N		Electroless Nickel Plating	C3~10	7205 P5	730	EX-STOCK	 <p>★Q option</p> <p>Electroless Nickel Plating (Application : Clean room)</p>
AK25_C5N			C5 ~ C10	7205 P0	730	3 days	
AK25B_C5N			C5 ~ C10	7205B P0	730	3 days	
AK25_C3N			C3	7205 P5	730	3 days	

Note :

1. All types make Preload.
2. All of bearings use Japanese & Taiwanese brand bearings (Model No. in blue), Assembly by DF way. The most suitable way for ballscrew use.
3. The standard type is without Q, if required, please advise in advance.

Support Unit AF
(supported-side rectangular type)

No.	Part name	Qty
1	Housing	1
2	Bearing	1 set
3	Snap ring	1
4	Cushion Stopper (option)	1

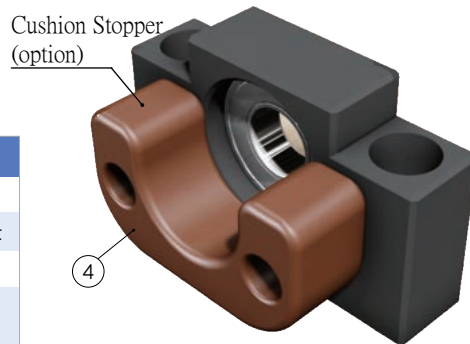

AF10~AF20

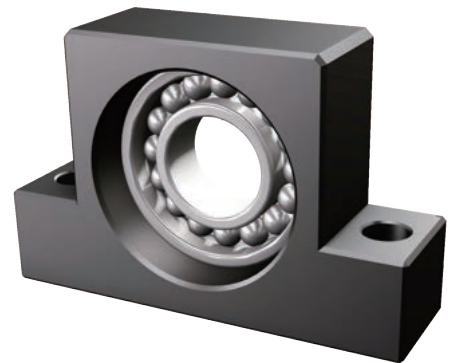

AF25

AF

2X drill $\varnothing Y$ counter bore depth Z

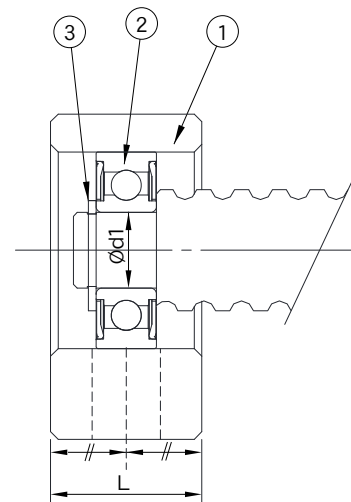
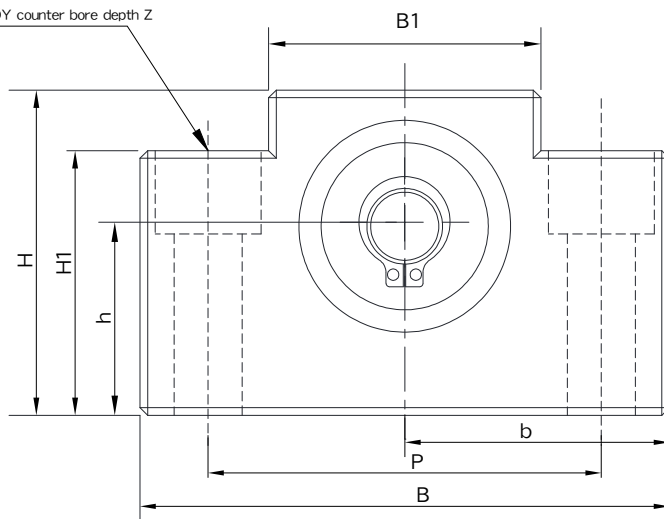

Unit : mm

Model No.	Shaft diameter d1	L	B	H	b	h	B1	H1	P	X	Y	Z	Bearing	Snap ring	Weight (Kgs)
					± 0.02	± 0.02									
AF10	8	20	70	43	35	25	36	35	52	9	14	11	608ZZ	S 08	0.37
AF12	10	20	70	43	35	25	36	35	52	9	14	11	6000ZZ	S 10	0.35
AF15	15	20	80	50	40	30	41	40	60	9	14	11	6002ZZ	S 15	0.45
AF20	20	26	95	58	47.5	30	56	45	75	11	17	15	6204ZZ	S 20	0.74
AF25	25	30	105	68	52.5	35	66	25	85	11	-	-	6205ZZ	S 25	0.93

Support Unit AF (Supported-side rectangular type)

Order Coding	Model No.	Surface treatment	Applicable ballscrew accuracy grade	Bearing	Delivery date 	
AF10_C3	AF10	Black Oxide	C3 ~ C7	608ZZ	EX-STOCK	 Black Oxide (Application : General case)
AF10_C3N		Electroless Nickel Plating	C3 ~ C7	608VV	3 days	
AF12_C3	AF12	Black Oxide	C3 ~ C7	6000ZZ	EX-STOCK	 Electroless Nickel Plating (Application : Clean room)
AF12_C3N		Electroless Nickel Plating	C3 ~ C7	6000VV	3 days	
AF15_C3	AF15	Black Oxide	C3 ~ C7	6002ZZ	EX-STOCK	 Electroless Nickel Plating (Application : Clean room)
AF15_C3N		Electroless Nickel Plating	C3 ~ C7	6002VV	EX-STOCK	
AF20_C3	AF20	Black Oxide	C3 ~ C7	6204ZZ	EX-STOCK	 Black Oxide (Application : General case)
AF20_C3N		Electroless Nickel Plating	C3 ~ C7	6204VV	3 days	
AF25_C3	AF25	Black Oxide	C3 ~ C7	6205ZZ	EX-STOCK	 Electroless Nickel Plating (Application : Clean room)
AF25_C3N		Electroless Nickel Plating	C3 ~ C7	6205VV	3 days	

Note :

1. It is used double pressed steel cages for Black Oxide type support units .
2. It is used double plastic cages for Electroless Nickel Plating type support units .
3. All of bearings use Japanese & Taiwanese brand bearings.

Support Unit BK (fixed-side rectangular type)

No.	Part name	Qty
1	Housing	1
2	Bearing	1 set
3	Holding lid	1
4	Collar	2
5	Seal	2
6	Lock nut	1set
7	Cushion Stopper (option)	1

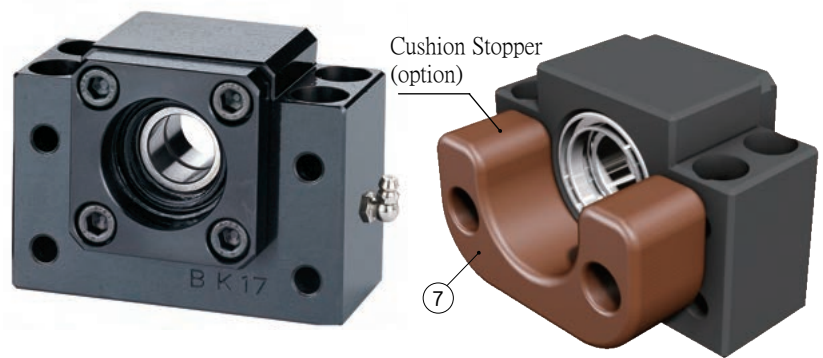

BK10~BK20

BK

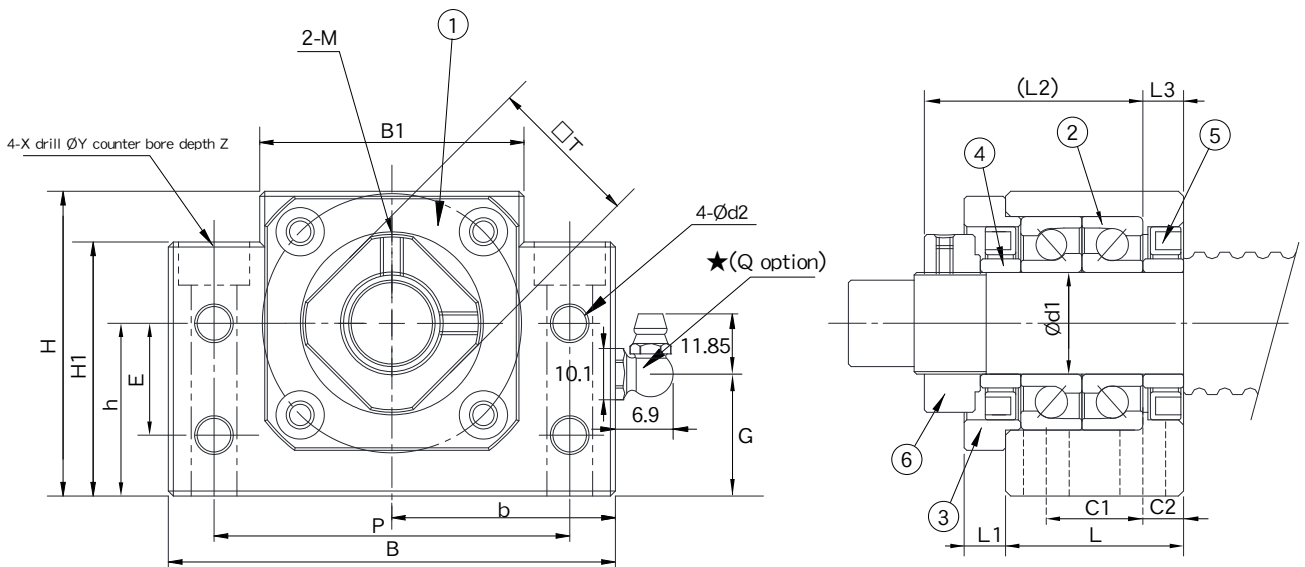

Unit : mm

Model No.	Shaft diameter d1	L	L1	L2	L3	B	H	b		B1	H1	E	P	C1	C2	d2	X	Y	Z	M	T	G	Q	Weight (Kgs)
								±0.02	±0.02															
BK10	10	25	5	29.5	5	60	39	30	22	34	32.5	15	46	13	6	5.5	6.6	10.8	5	M3	16	15	M6	0.4
BK12	12	25	5	29.5	5	60	43	30	25	34	32.5	18	46	13	6	5.5	6.6	10.8	1.5	M4	19	18	M6	0.42
BK15	15	27	6	32	6	70	48	35	28	40	38	18	54	15	6	5.5	6.6	11	6.5	M4	22	18	M6	0.59
BK17	17	35	9	44	7	86	64	43	39	50	55	28	68	19	8	6.6	9	14	8.5	M4	24	30	M6	1.34
BK20	20	35	8	43	8	88	60	44	34	52	50	22	70	19	8	6.6	9	14	8.5	M4	30	24	M6	1.2
BK25	25	42	12	54	9	106	80	53	48	64	70	33	85	22	10	9	11	17	11	M6	35	37	M6	2.37
BK30	30	45	14	61	9	128	89	64	51	76	78	33	102	23	11	11	14	20	13	M6	40	37	M6	3.37
BK35	35	50	14	67	12	140	96	70	52	88	79	35	114	26	12	11	14	20	13	M6	50	37	M6	4.43
BK40	40	61	18	76	15	160	110	80	60	100	90	37	130	33	14	14	18	26	17.5	M6	50	43	M6	6.84

Support Unit BK (fixed-side rectangular type)

Order Coding	Model No.	Surface treatment	Applicable ballscrew accuracy grade	Bearing		Delivery date
				Model No.	Max. Starting torque (gf-cm)	
BK10	BK10	Black Oxide	C3 ~ C10	7000A P5	190	EX-STOCK
BK10_C5			C5 ~ C10	7000A P0	190	EX-STOCK
BK10_C3			C3	7000A P5	190	EX-STOCK
BK10_N		Electroless Nickel Plating	C3 ~ C10	7000A P5	190	EX-STOCK
BK10_C5N			C5 ~ C10	7000A P0	190	3 days
BK10_C3N			C3	7000A P5	190	3 days
BK12	BK12	Black Oxide	C3 ~ C10	7001A P5	210	EX-STOCK
BK12_C5			C5 ~ C10	7001A P0	210	EX-STOCK
BK12_C3			C3	7001A P5	210	EX-STOCK
BK12_N		Electroless Nickel Plating	C3 ~ C10	7001A P5	210	EX-STOCK
BK12_C5N			C5 ~ C10	7001A P0	210	EX-STOCK
BK12_C3N			C3	7001A P5	210	3 days
BK15	BK15	Black Oxide	C3 ~ C10	7002A P5	230	EX-STOCK
BK15_C5			C5 ~ C10	7002A P0	230	EX-STOCK
BK15_C3			C3	7002A P5	230	EX-STOCK
BK15_N		Electroless Nickel Plating	C3 ~ C10	7002A P5	230	EX-STOCK
BK15_C5N			C5 ~ C10	7002A P0	230	EX-STOCK
BK15_C3N			C3	7002A P5	230	3 days
BK17	BK17	Black Oxide	C3 ~ C10	7203A P5	370	EX-STOCK
BK17_C3			C3	7203A P5	370	3 days
BK17_N		Electroless Nickel Plating	C3 ~ C10	7203A P5	370	EX-STOCK
BK17_C3N			C3	7203A P5	370	3 days
BK20	BK20	Black Oxide	C3 ~ C10	7004A P5	380	EX-STOCK
BK20_C5			C5 ~ C10	7004A P0	380	3 days
BK20_C3			C3	7004A P5	380	3 days
BK20_N		Electroless Nickel Plating	C3 ~ C10	7004A P5	380	EX-STOCK
BK20_C5N			C5 ~ C10	7004A P0	380	3 days
BK20_C3N			C3	7004A P5	380	3 days



Black Oxide
(Application : General case)



Electroless Nickel Plating
(Application : Clean room)

Note :

1. All types make Preload.
2. All of bearings use Japanese & Taiwanese brand bearings (Model No. in blue), Assembly by DF way. The most suitable way for ballscrew use.
3. The standard type is without Q, if required, please advise in advance.

Support Unit BK (fixed-side rectangular type)

Order Coding	Model No.	Surface treatment	Applicable ballscrew accuracy grade	Bearing		Delivery date 
				Model No.	Max. Starting torque (gf-cm)	
BK25	BK25	Black Oxide	C3 ~ C10	7205 P5	730	EX-STOCK
BK25_C5			C5 ~ C10	7205 P0	730	EX-STOCK
BK25B_C5			C5 ~ C10	7205B P0	730	EX-STOCK
BK25_C3			C3	7205 P5	730	EX-STOCK
BK25_N		Electroless Nickel Plating	C3 ~ C10	7205 P5	730	EX-STOCK
BK25_C5N			C5 ~ C10	7205 P0	730	3 days
BK25B_C5N			C5 ~ C10	7205B P0	730	3 days
BK25_C3N			C3	7205 P5	730	3 days
BK30_C5	BK30	Black Oxide	C5 ~ C10	7206 P0	1050	EX-STOCK
BK30B_C5			C5 ~ C10	7206B P0	1050	EX-STOCK
BK30_C5N		Electroless Nickel Plating	C5 ~ C10	7206 P0	1050	EX-STOCK
BK30B_C5N			C5 ~ C10	7206B P0	1050	3 days
BK35_C5	BK35	Black Oxide	C5 ~ C10	7207B P0	1320	EX-STOCK
BK35_C5N		Electroless Nickel Plating	C5 ~ C10	7207B P0	1320	3 days
BK40_C5	BK40	Black Oxide	C5 ~ C10	7208B P0	2050	EX-STOCK
BK40_C5N		Electroless Nickel Plating	C5 ~ C10	7208B P0	2050	EX-STOCK



Note :

1. All types make Preload.
2. All of bearings use Japanese & Taiwanese brand bearings(Model No. in blue), Assembly by DF way. The most suitable way for ballscrew use.
3. The standard type is without Q , if required, please advise in advance.

Support Unit BF (Supported-side rectangular type)

No.	Part name	Qty
1	Housing	1
2	Bearing	1 set
3	Snap ring	1
4	Cushion Stopper (option)	1

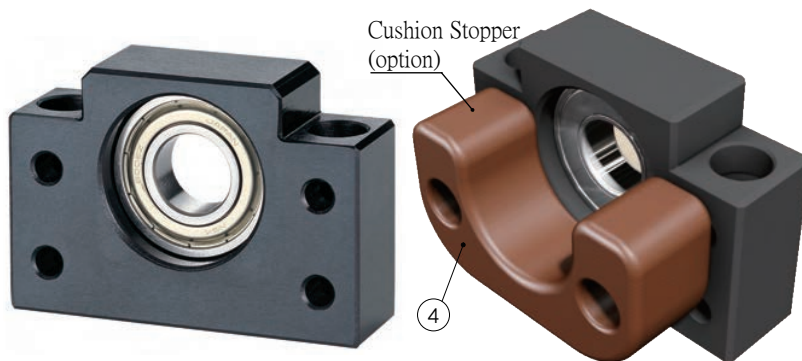

BF10~BF30

BF

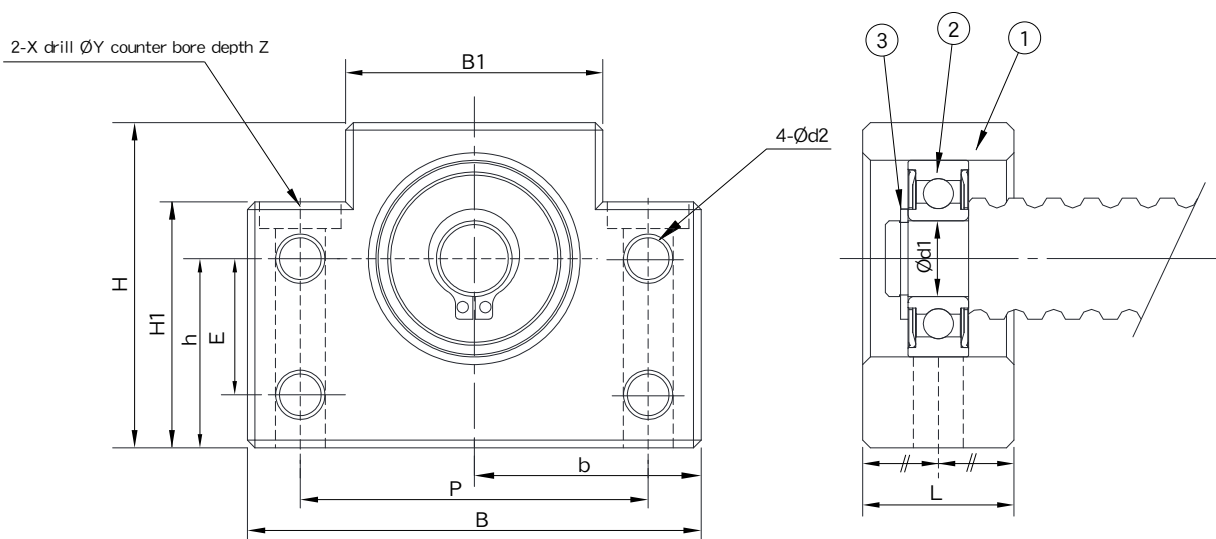

Unit : mm

Model No.	Shaft diameter d1	L	B	H	b ±0.02	h ±0.02	B1	H1	E	P	d2	X	Y	Z	Bearing	Snap ring	Weight (Kgs)
BF10	8	20	60	39	30	22	34	32.5	15	46	5.5	6.6	10.8	5	608ZZ	S 08	0.3
BF12	10	20	60	43	30	25	34	32.5	18	46	5.5	6.6	10.8	1.5	6000ZZ	S 10	0.3
BF15	15	20	70	48	35	28	40	38	18	54	5.5	6.6	11	6.5	6002ZZ	S 15	0.38
BF17	17	23	86	64	43	39	50	55	28	68	6.6	9	14	8.5	6203ZZ	S 17	0.75
BF20	20	26	88	60	44	34	52	50	22	70	6.6	9	14	8.5	6004ZZ	S 20	0.77
BF20H	20	26	88	74	44	48	52	64	-	70	-	9	14	8.5	6004ZZ	S20	1.03
SF20	20	30	106	80	53	48	64	70	-	85	-	11	17	11	6204ZZ	S20	-
BF25	25	30	106	80	53	48	64	70	33	85	9	11	17	11	6205ZZ	S 25	1.44
SF25	25	32	128	89	64	51	76	78	-	102	-	14	20	13	6205ZZ	S 25	2.17
BF30	30	32	128	89	64	51	76	78	33	102	11	14	20	13	6206ZZ	S 30	1.97
BF35	35	32	140	96	70	52	88	79	35	114	11	14	20	13	6207ZZ	S 35	2.27
SF40	40	32	140	96	70	52	88	79	-	114	-	14	20	13	6208ZZ	S 40	2.18
BF40	40	37	160	110	80	60	100	90	37	130	14	18	26	17.5	6208ZZ	S 40	3.28



Support Unit BF (Supported-side rectangular type)

Order Coding	Model No.	Surface treatment	Applicable ballscrew accuracy grade	Bearing	Delivery date
BF10_C3	BF10	Black Oxide	C3 ~ C7	608ZZ	EX-STOCK
BF10_C3N		Electroless Nickel Plating	C3 ~ C7	608VV	EX-STOCK
BF12_C3	BF12	Black Oxide	C3 ~ C7	6000ZZ	EX-STOCK
BF12_C3N		Electroless Nickel Plating	C3 ~ C7	6000VV	EX-STOCK
BF15_C3	BF15	Black Oxide	C3 ~ C7	6002ZZ	EX-STOCK
BF15_C3N		Electroless Nickel Plating	C3 ~ C7	6002VV	EX-STOCK
BF17_C3	BF17	Black Oxide	C3 ~ C7	6203ZZ	EX-STOCK
BF17_C3N		Electroless Nickel Plating	C3 ~ C7	6203VV	EX-STOCK
BF20_C3	BF20	Black Oxide	C3 ~ C7	6004ZZ	EX-STOCK
BF20_C3N		Electroless Nickel Plating	C3 ~ C7	6004VV	EX-STOCK
BF25_C3	BF25	Black Oxide	C3 ~ C7	6205ZZ	EX-STOCK
BF25_C3N		Electroless Nickel Plating	C3 ~ C7	6205VV	EX-STOCK
BF30_C3	BF30	Black Oxide	C3 ~ C7	6206ZZ	EX-STOCK
BF30_C3N		Electroless Nickel Plating	C3 ~ C7	6206VV	EX-STOCK
BF35_C3	BF35	Black Oxide	C3 ~ C7	6207ZZ	EX-STOCK
BF35_C3N		Electroless Nickel Plating	C3 ~ C7	6207VV	EX-STOCK
BF40_C3	BF40	Black Oxide	C3 ~ C7	6208ZZ	EX-STOCK
BF40_C3N		Electroless Nickel Plating	C3 ~ C7	6208VV	EX-STOCK



Black Oxide
(Application : General case)



Electroless Nickel Plating
(Application : Clean room)

Note :

1. It is used double pressed steel cages for Black Oxide type support units .
2. It is used double plastic cages for Electroless Nickel Plating type support units .
3. All of bearings use Japanese & Taiwanese brand bearings.

Support Unit HF

Pattern : HF15H

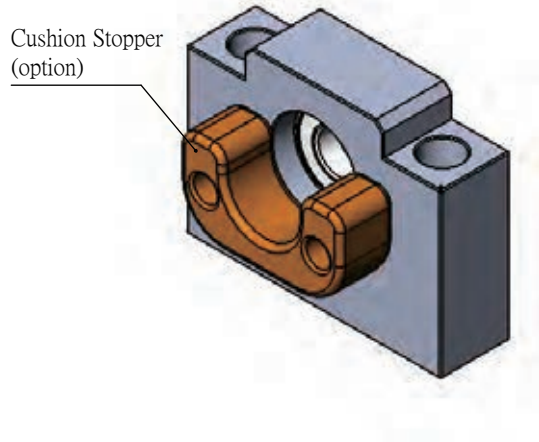

No.	Part name	Qty
1	Housing	1
2	Bearing	1 set
3	Snap ring	1
4	Cushion Stopper (option)	1

HF

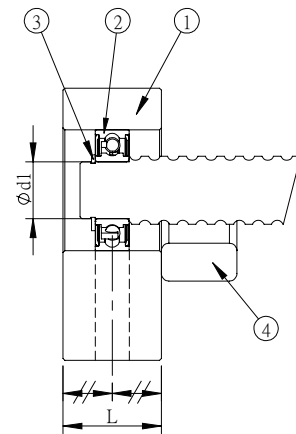
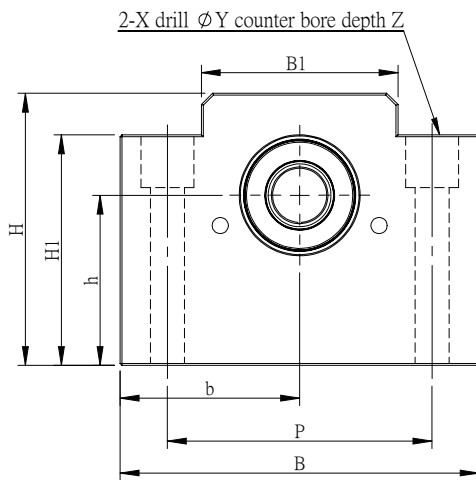

Unit : mm

Model No.	Shaft diameter d1	L	B	H	b	h	B1	H1	P	X	Y	Z	Bearing	Snap ring	Weight (Kgs)
					±0.02	±0.02									
HF15	15	20	70	50	35	30	41	40	60	6.6	12	10	6002ZZ	S 15	0.41
HF15H	15	26	95	72	47.5	45	52	61	70	9	14	14	6002ZZ	S 15	1.13

Support Unit EK
(fixed-side rectangular type)

EK05

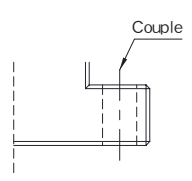

No.	Part name	Qty
1	Housing	1
2	Bearing	1 set
3	Holding lid	1
4	Collar	2
5	Seal	1 (2)
6	Lock nut	1
7	Cushion Stopper (option)	1
8	Cushion Stopper (option)	2

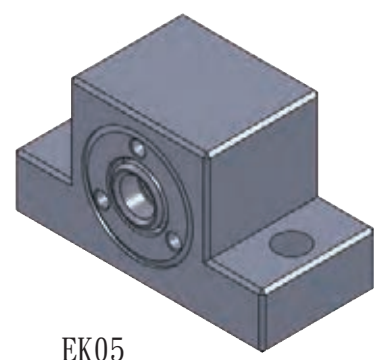

EK05

EK06, EK08

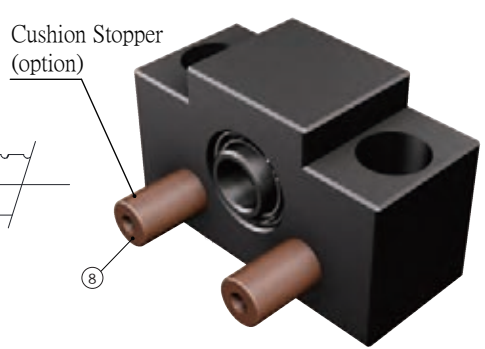
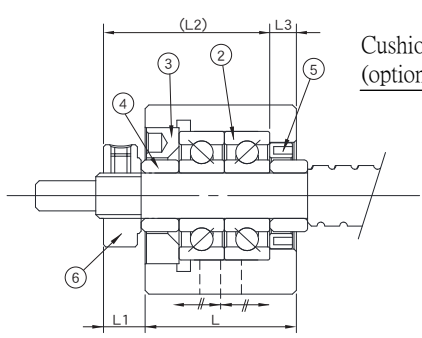
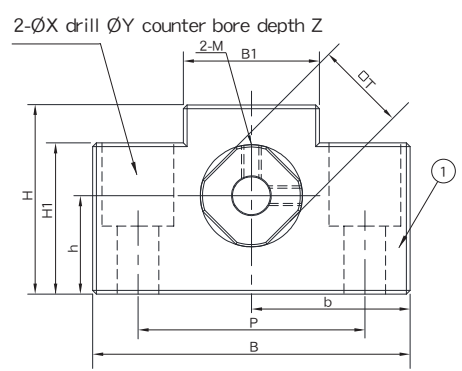

(EK06~08)

EK10~EK20

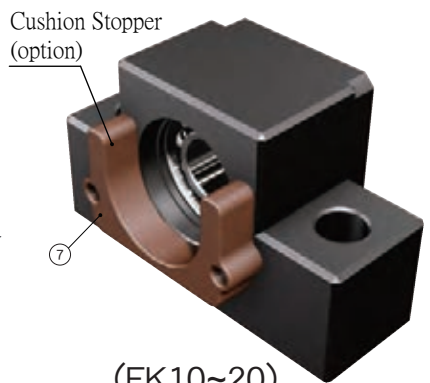
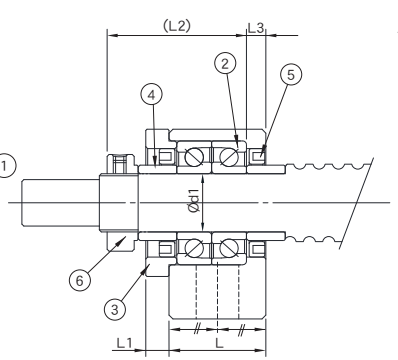
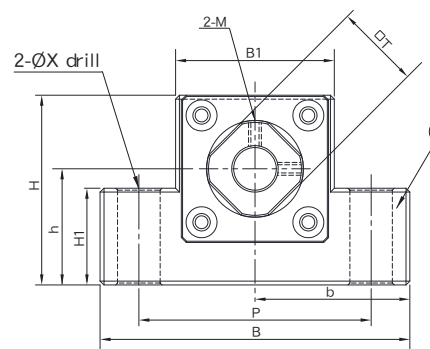

(EK10~20)

Unit : mm

Model No.	Shaft diameter d1	L	L1	L2	L3	B	H	b	h	B1	H1	P	X	Y	Z	M	T	Weight (Kgs)
								±0.02	±0.02									
EK05	5	16.5	5.5	18.5	3.5	36	21	18	11	20	8	28	4.5	-	-	M3	11	0.1
EK06	6	20	5.5	22	3.5	42	25	21	13	18	20	30	5.5	9.5	11	M3	12	0.16
EK08	8	23	7	26	4	52	32	26	17	25	26	38	6.6	11	12	M3	14	0.26
EK10-1	10	24	6	29.5	6	65	43	32.5	21	36	20	52	6.6	-	-	M3	16	0.45
EK10	10	24	6	29.5	6	70	43	35	25	36	24	52	9	-	-	M3	16	0.46
EK12	12	24	6	29.5	6	70	43	35	25	36	24	52	9	-	-	M4	19	0.44
EK15	15	25	6	36	5	80	50	40	30	41	25	60	11	-	-	M4	22	0.58
EK20	20	42	10	50	10	95	58	47.5	30	56	25	75	11	-	-	M4	30	1.35
SK20	20	42	10	50	10	106	80	53	48	64	70	85	11	17	11	M4	30	-



Support Unit EK (fixed-side rectangular type)

Order Coding	Model No.	Surface treatment	Applicable ballscrew accuracy grade	Bearing		Delivery date
				Model No.	Max. Starting torque (gf-cm)	
EK06	EK06	Black Oxide	C3~C10	706A P5	50	EX-STOCK
EK06_C5			C5 ~ C10	706A P0	50	EX-STOCK
EK06_C3			C3	706A P5	50	3 days
EK06_N		Electroless Nickel Plating	C3~C10	706A P5	50	3 days
EK06_C5N			C5 ~ C10	706A P0	50	3 days
EK06_C3N			C3	706A P5	50	3 days
 <p>Black Oxide (Application : General case)</p>						
EK08	EK08	Black Oxide	C3 ~ C10	708A P5	90	EX-STOCK
EK08_C5			C5 ~ C10	708A P0	90	EX-STOCK
EK08_C3			C3	708A P5	90	EX-STOCK
EK08_N		Electroless Nickel Plating	C3 ~ C10	708A P5	90	EX-STOCK
EK08_C5N			C5 ~ C10	708A P0	90	3 days
EK08_C3N			C3	708A P5	90	3 days
 <p>Electroless Nickel Plating (Application : Clean room)</p>						
EK10	EK10	Black Oxide	C3 ~ C10	7000A P5	190	EX-STOCK
EK10_C5			C5 ~ C10	7000A P0	190	EX-STOCK
EK10_C3			C3	7000A P5	190	EX-STOCK
EK10_N		Electroless Nickel Plating	C3 ~ C10	7000A P5	190	EX-STOCK
EK10_C5N			C5 ~ C10	7000A P0	190	3 days
EK10_C3N			C3	7000A P5	190	3 days
 <p>Black Oxide (Application : General case)</p>						
EK12	EK12	Black Oxide	C3 ~ C10	7001A P5	210	EX-STOCK
EK12_C5			C5 ~ C10	7001A P0	210	EX-STOCK
EK12_C3			C3	7001A P5	210	EX-STOCK
EK12_N		Electroless Nickel Plating	C3 ~ C10	7001A P5	210	EX-STOCK
EK12_C5N			C5 ~ C10	7001A P0	210	3 days
EK12_C3N			C3	7001A P5	210	3 days
 <p>Electroless Nickel Plating (Application : Clean room)</p>						

Note :

1. All types make Preload.
2. All of bearings use Japanese & Taiwanese brand bearings (Model No. in blue), Assembly by DF way. The most suitable way for ballscrew use.

Support Unit EK (fixed-side rectangular type)

Order Coding	Model No.	Surface treatment	Applicable ballscrew accuracy grade	Bearing		Delivery date 
				Model No.	Max. Starting torque (gf·cm)	
EK15	EK15	Black Oxide	C3 ~ C10	7002A P5	230	EX-STOCK
EK15_C5			C5 ~ C10	7002A P0	230	EX-STOCK
EK15_C3			C3	7002A P5	230	EX-STOCK
EK15_N		Electroless Nickel Plating	C3 ~ C10	7002A P5	230	EX-STOCK
EK15_C5N			C5 ~ C10	7002A P0	230	3 days
EK15_C3N			C3	7002A P5	230	3 days
EK20	EK20	Black Oxide	C3 ~ C10	7204 P5	550	EX-STOCK
EK20_C5			C5 ~ C10	7204 P0	550	3 days
EK20B_C5			C5 ~ C10	7204B P0	550	EX-STOCK
EK20_C3			C3	7204 P5	550	3 days
EK20_N		Electroless Nickel Plating	C3 ~ C10	7204 P5	550	EX-STOCK
EK20_C5N			C5 ~ C10	7204 P0	550	3 days
EK20B_C5N			C5 ~ C10	7204B P0	550	3 days
EK20_C3N			C3	7204 P5	550	3 days
SK20			SK20	Black Oxide	C3 ~ C10	7204 P5
SK20_C3	C3	7204 P5			550	3 days
SK20_N	Electroless Nickel Plating	C3 ~ C10		7204 P5	550	Customized
SK20_C3N		C3		7204 P5	550	Customized



Black Oxide (Application : General case)



Electroless Nickel Plating (Application : Clean room)

Note :

1. All types make Preload.
2. All of bearings use Japanese & Taiwanese brand bearings (Model No. in blue), Assembly by DF way. The most suitable way for ballscrew use.

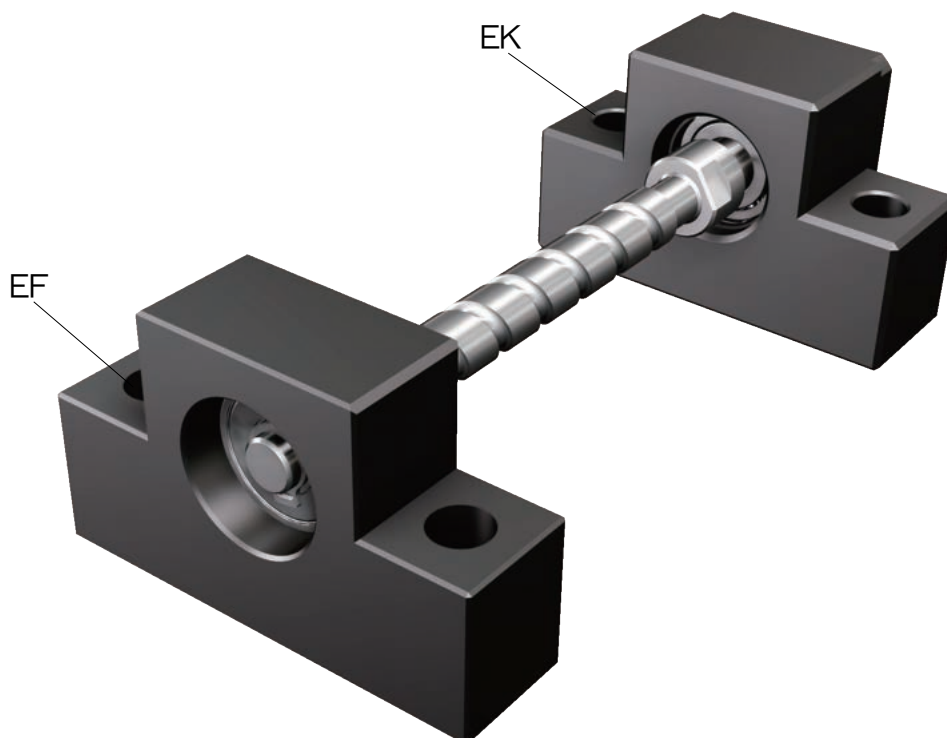

Support Unit EF (supported-side rectangular type)

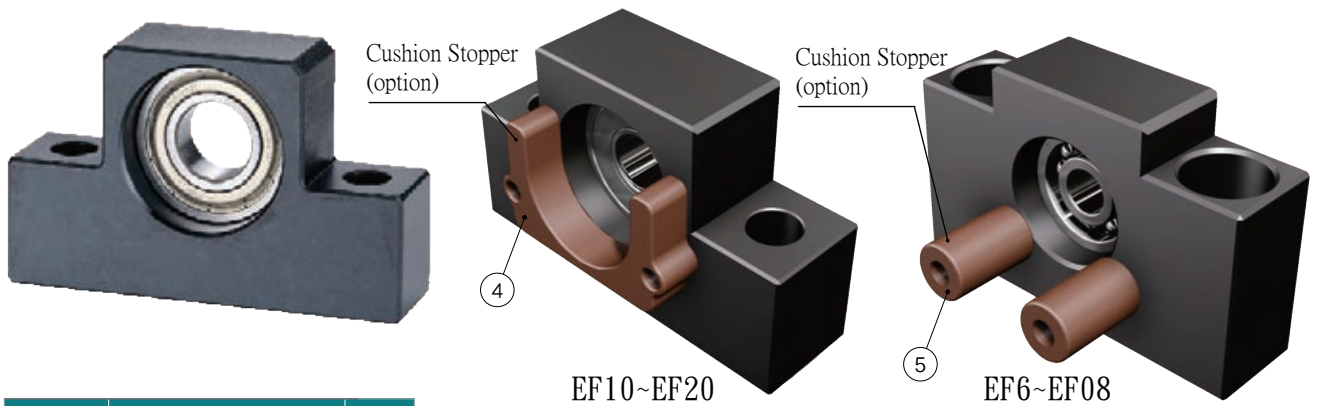

No.	Part name	Qty
1	Housing	1
2	Bearing	1 set
3	Snap ring	1
4	Cushion Stopper (option)	1
5	Cushion Stopper (option)	2

EF

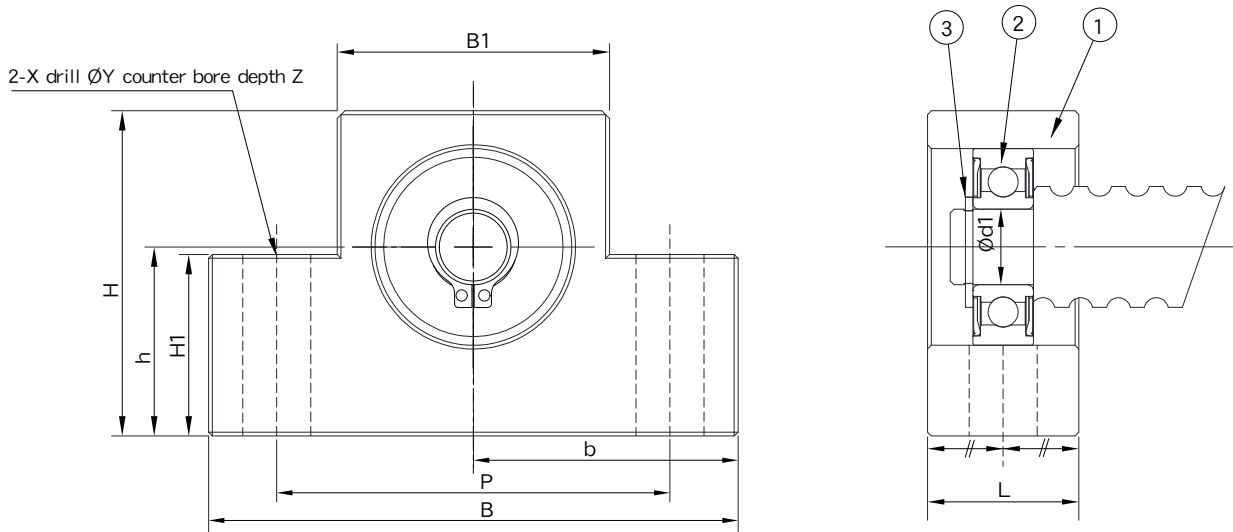

Model No.	Shaft diameter d1	L	B	H	b		B1	H1	P	X	Y	Z	Bearing	Snap ring	Weight (Kgs)
					±0.02	±0.02									
EF06	6	12	42	25	21	13	18	20	30	5.5	9.5	11	606ZZ	S 06	0.09
EF08	6	14	52	32	26	17	25	26	38	6.6	11	12	606ZZ	S 06	0.16
EF10	8	20	70	43	35	25	36	24	52	9	-	-	608ZZ	S 08	0.34
EF12	10	20	70	43	35	25	36	24	52	9	-	-	6000ZZ	S 10	0.32
EF15	15	20	80	50	40	30	41	25	60	9	-	-	6002ZZ	S 15	0.39
EF20	20	26	95	58	47.5	30	56	25	75	11	-	-	6204ZZ	S 20	0.64

Unit : mm

Support Unit EF (Supported-side rectangular type)

Order Coding	Model No.	Surface treatment	Applicable ballscrew accuracy grade	Bearing	Delivery date	
EF06_C3	EF06	Black Oxide	C3 ~ C7	606ZZ	EX-STOCK	 Black Oxide (Application : General case)
EF06_C3N		Electroless Nickel Plating	C3 ~ C7	606VV	3 days	
EF08_C3	EF08	Black Oxide	C3 ~ C7	606ZZ	EX-STOCK	
EF08_C3N		Electroless Nickel Plating	C3 ~ C7	606VV	EX-STOCK	
EF10_C3	EF10	Black Oxide	C3 ~ C7	608ZZ	EX-STOCK	 Electroless Nickel Plating (Application : Clean room)
EF10_C3N		Electroless Nickel Plating	C3 ~ C7	608VV	EX-STOCK	
EF12_C3	EF12	Black Oxide	C3 ~ C7	6000ZZ	EX-STOCK	
EF12_C3N		Electroless Nickel Plating	C3 ~ C7	6000VV	EX-STOCK	
EF15_C3	EF15	Black Oxide	C3 ~ C7	6002ZZ	EX-STOCK	
EF15_C3N		Electroless Nickel Plating	C3 ~ C7	6002VV	EX-STOCK	
EF20_C3	EF20	Black Oxide	C3 ~ C7	6204ZZ	EX-STOCK	
EF20_C3N		Electroless Nickel Plating	C3 ~ C7	6204VV	EX-STOCK	

Note :

1. It is used double pressed steel cages for Black Oxide type support units .
2. It is used double plastic cages for Electroless Nickel Plating type support units .
3. All of bearings use Japanese & Taiwanese brand bearings.

Support Unit FK
(fixed-side round type)

No.	Part name	Qty
1	Housing	1
2	Bearing	1 set
3	Holding lid	1
4	Collar	2
5	Seal	2
6	Lock nut	1set



FK05~FK08

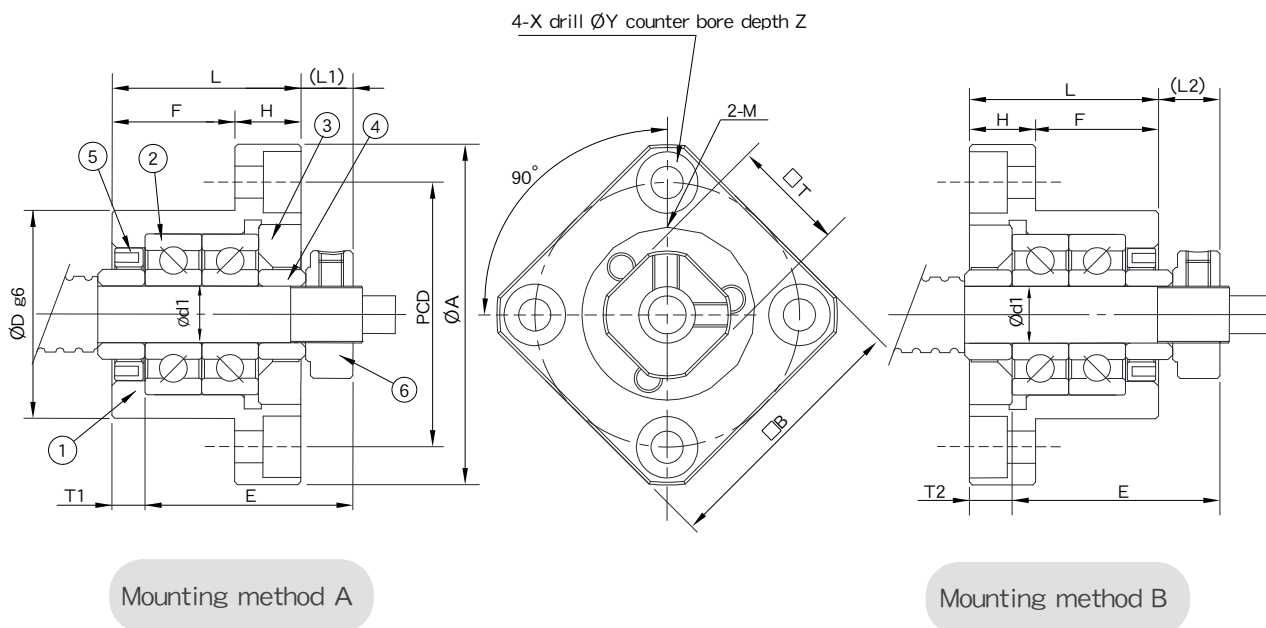

Mounting method A

Mounting method B

Unit : mm

Model No.	Shaft diameter d1	L	H	F	E	Dg6	A	PCD	B	Mounting method A		Mounting method B		X	Y	Z	M	T	Weight (Kgs)
										L1	T1	L2	T2						
FK05	5	16.5	6	10.5	18.5	20 ^{-0.007/-0.02}	34	26	26	5.5	3.5	5	3	3.4	6.5	3.5	M3	11	0.09
FK06	6	20	7	13	22	22 ^{-0.007/-0.02}	36	28	28	5.5	3.5	6.5	4.5	3.4	6.5	4	M3	12	0.1
FK08	8	23	9	14	26	28 ^{-0.007/-0.02}	43	35	35	7	4	8	5	3.4	6.5	4	M3	14	0.16

Support Unit FK (fixed-side round type)

No.	Part name	Qty
1	Housing	1
2	Bearing	1 set
3	Holding lid	1
4	Collar	2
5	Seal	1
6	Lock nut	1set



The position of oil grease is for reference only, please visit our website to get more information on it.

FK10~FK30

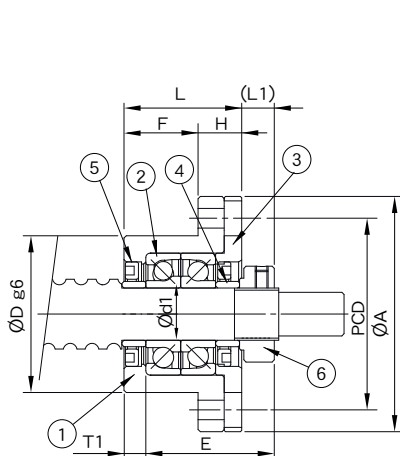

Mounting method A

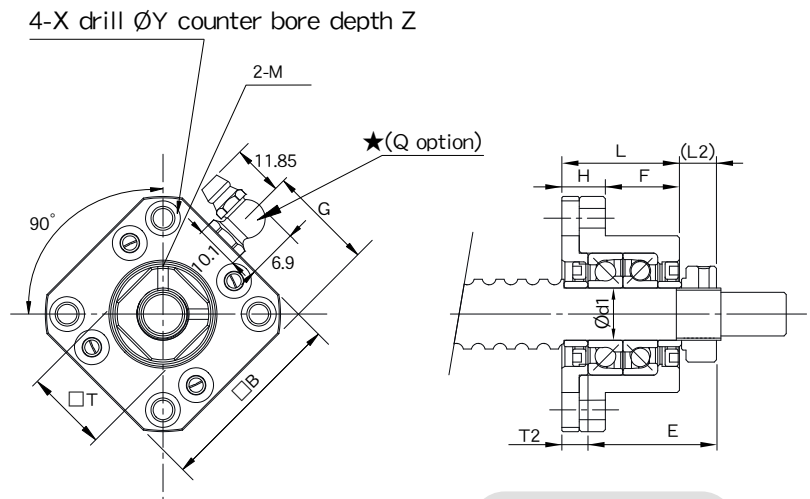

Mounting method B

Unit : mm

Model No.	Shaft diameter d1	L	H	F	E	Dg6	A	PCD	B	Mounting method A		Mounting method B		X	Y	Z	M	T	G	Q	Weight (Kgs)
										L1	T1	L2	T2								
FK10	10	27	10	17	29.5	34 -0.009 -0.025	52	42	42	7.5	5	8.5	6	4.5	8	4	M3	16	-	-	0.24
FK12	12	27	10	17	29.5	36 -0.009 -0.025	54	44	44	7.5	5	8.5	6	4.5	8	4	M4	19	-	-	0.26
FK15	15	32	15	17	36	40 -0.009 -0.025	63	50	52	10	6	12	8	5.5	9.5	6	M4	22	26	M6	0.41
FK17	17	45	22	23	47	50 -0.009 -0.025	77	62	61	11	9	14	12	6.6	11	10	M4	24	30.5	M6	0.81
FK20	20	52	22	30	50	57 -0.010 -0.029	85	70	68	8	10	12	14	6.6	11	10	M4	30	34	M6	1.05
FK25	25	57	27	30	59	63 -0.010 -0.029	98	80	79	13	10	20	17	9	15	13	M5	35	39.5	M6	1.52
FK30	30	62	30	32	61	75 -0.010 -0.029	117	95	93	11	12	17	18	11	17.5	15	M6	40	46.5	M6	2.21

Support Unit FK (fixed-side round type)

Order Coding	Model No.	Surface treatment	Applicable ballscrew accuracy grade	Bearing		Delivery date
				Model No.	Max. Starting torque (gf-cm)	
FK06	FK06	Black Oxide	C3~C10	706A P5	50	EX-STOCK
FK06_C5			C5 ~ C10	706A P0	50	EX-STOCK
FK06_C3			C3	706A P5	50	EX-STOCK
FK06_N		Electroless Nickel Plating	C3~C10	706A P5	50	3 days
FK06_C5N			C5 ~ C10	706A P0	50	3 days
FK06_C3N			C3	706A P5	50	3 days
 <p>Black Oxide (Application : General case)</p>						
FK08	FK08	Black Oxide	C3 ~ C10	708A P5	90	EX-STOCK
FK08_C5			C5 ~ C10	708A P0	90	EX-STOCK
FK08_C3			C3	708A P5	90	EX-STOCK
FK08_N		Electroless Nickel Plating	C3 ~ C10	708A P5	90	EX-STOCK
FK08_C5N			C5 ~ C10	708A P0	90	3 days
FK08_C3N			C3	708A P5	90	3 days
 <p>Electroless Nickel Plating (Application : Clean room)</p>						
FK10	FK10	Black Oxide	C3 ~ C10	7000A P5	190	EX-STOCK
FK10_C5			C5 ~ C10	7000A P0	190	EX-STOCK
FK10_C3			C3	7000A P5	190	EX-STOCK
FK10_N		Electroless Nickel Plating	C3 ~ C10	7000A P5	190	EX-STOCK
FK10_C5N			C5 ~ C10	7000A P0	190	3 days
FK10_C3N			C3	7000A P5	190	3 days
 <p>Black Oxide (Application : General case)</p>						
FK12	FK12	Black Oxide	C3 ~ C10	7001A P5	210	EX-STOCK
FK12_C5			C5 ~ C10	7001A P0	210	EX-STOCK
FK12_C3			C3	7001A P5	210	EX-STOCK
FK12_N		Electroless Nickel Plating	C3 ~ C10	7001A P5	210	EX-STOCK
FK12_C5N			C5 ~ C10	7001A P0	210	EX-STOCK
FK12_C3N			C3	7001A P5	210	EX-STOCK
 <p>Black Oxide (Application : General case)</p>						
FK15	FK15	Black Oxide	C3 ~ C10	7002A P5	230	EX-STOCK
FK15_C5			C5 ~ C10	7002A P0	230	EX-STOCK
FK15_C3			C3	7002A P5	230	EX-STOCK
FK15_N		Electroless Nickel Plating	C3 ~ C10	7002A P5	230	EX-STOCK
FK15_C5N			C5 ~ C10	7002A P0	230	EX-STOCK
FK15_C3N			C3	7002A P5	230	3 days
 <p>Electroless Nickel Plating (Application : Clean room)</p>						

Note :

1. All types make Preload.
2. All of bearings use Japanese & Taiwanese brand bearings (Model No. in blue), Assembly by DF way. The most suitable way for ballscrew use.

Support Unit FK (fixed-side round type)

Order Coding	Model No.	Surface treatment	Applicable ballscrew accuracy grade	Bearing		Delivery date
				Model No.	Max. Starting torque (gf-cm)	
FK17	FK17	Black Oxide	C3 ~ C10	7203A P5	370	EX-STOCK
FK17_C3			C3	7203A P5	370	3 days
FK17_N		Electroless Nickel Plating	C3 ~ C10	7203A P5	370	EX-STOCK
FK17_C3N			C3	7203A P5	370	3 days
FK20	FK20	Black Oxide	C3 ~ C10	7204 P5	550	EX-STOCK
FK20_C5			C5 ~ C10	7204 P0	550	EX-STOCK
FK20B_C5			C5 ~ C10	7204B P0	550	EX-STOCK
FK20_C3			C3	7204 P5	550	EX-STOCK
FK20_N		Electroless Nickel Plating	C3 ~ C10	7204 P5	550	EX-STOCK
FK20_C5N			C5 ~ C10	7204 P0	550	3 days
FK20B_C5N			C5 ~ C10	7204B P0	550	3 days
FK20_C3N			C3	7204 P5	550	3 days
FK25			FK25	Black Oxide	C3 ~ C10	7205 P5
FK25_C5	C5 ~ C10	7205 P0			730	EX-STOCK
FK25B_C5	C5 ~ C10	7205B P0			730	EX-STOCK
FK25_C3	C3	7205 P5			730	3 days
FK25_N	Electroless Nickel Plating	C3 ~ C10		7205 P5	730	EX-STOCK
FK25_C5N		C5 ~ C10		7205 P0	730	3 days
FK25B_C5N		C5 ~ C10		7205B P0	730	3 days
FK25_C3N		C3		7205 P5	730	3 days
FK30_C5		FK30		Black Oxide	C5 ~ C10	7206 P0
FK30B_C5	C5 ~ C10		7206B P0		1050	EX-STOCK
FK30_C5N	Electroless Nickel Plating		C5 ~ C10	7206 P0	1050	EX-STOCK
FK30B_C5N			C5 ~ C10	7206B P0	1050	3 days



Note :

- 1.All types make Preload.
2. All of bearings use Japanese & Taiwanese brand bearings(Model No. in blue), Assembly by DF way. The most suitable way for ballscrew use.
3. The standard type is without Q , if required, please advise in advance.

Support Unit FF
(Supported-side round type)



No.	Part name	Qty
1	Housing	1
2	Bearing	1 set
3	Snap ring	1

FF

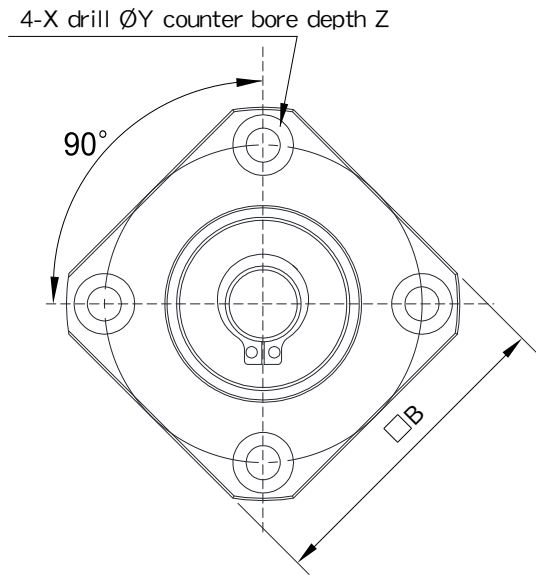
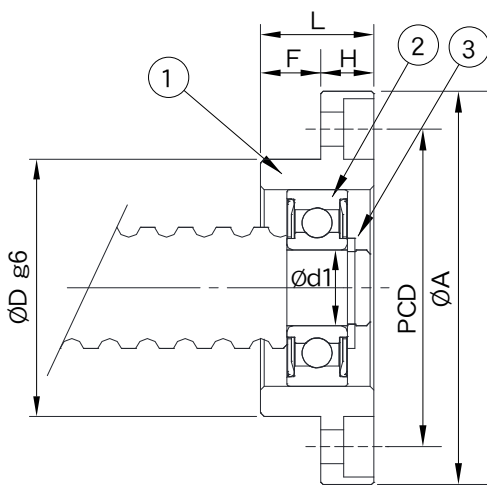

Unit : mm

Model No.	Shaft diameter d1	L	H	F	Dg6	A	PCD	B	X	Y	Z	Bearing	Snap ring	Weight (KGS)
FF06	6	10	6	4	22 $\begin{smallmatrix} -0.007 \\ -0.02 \end{smallmatrix}$	36	28	28	3.4	6.5	3.5	606ZZ	S 06	0.07
FF10	8	12	7	5	28 $\begin{smallmatrix} -0.007 \\ -0.02 \end{smallmatrix}$	43	35	35	3.4	6.5	4	608ZZ	S 08	0.09
FF12	10	15	7	8	34 $\begin{smallmatrix} -0.009 \\ -0.025 \end{smallmatrix}$	52	42	42	4.5	8	4	6000ZZ	S 10	0.14
FF15	15	17	9	8	40 $\begin{smallmatrix} -0.009 \\ -0.025 \end{smallmatrix}$	63	50	52	5.5	9.5	5.5	6002ZZ	S 15	0.21
FF17	17	20	11	9	50 $\begin{smallmatrix} -0.009 \\ -0.025 \end{smallmatrix}$	77	62	61	6.6	11	6.5	6203ZZ	S17	0.33
FF20	20	20	11	9	57 $\begin{smallmatrix} -0.010 \\ -0.029 \end{smallmatrix}$	85	70	68	6.6	11	6.5	6204ZZ	S 20	0.44
FF25	25	24	14	10	63 $\begin{smallmatrix} -0.010 \\ -0.029 \end{smallmatrix}$	98	80	79	9	14	8.5	6205ZZ	S 25	0.68
FF30	30	27	18	9	75 $\begin{smallmatrix} -0.010 \\ -0.029 \end{smallmatrix}$	117	95	93	11	17	11	6206ZZ	S 30	1.06

Support Unit FF (Supported-side round type)

Order Coding	Model No.	Surface treatment	Applicable ballscrew accuracy grade	Bearing	Delivery date
FF06_C3	FF06	Black Oxide	C3 ~ C7	606ZZ	EX-STOCK
FF06_C3N		Electroless Nickel Plating	C3 ~ C7	606VV	3 days
FF10_C3	FF10	Black Oxide	C3 ~ C7	608ZZ	EX-STOCK
FF10_C3N		Electroless Nickel Plating	C3 ~ C7	608VV	EX-STOCK
FF12_C3	FF12	Black Oxide	C3 ~ C7	6000ZZ	EX-STOCK
FF12_C3N		Electroless Nickel Plating	C3 ~ C7	6000VV	EX-STOCK
FF15_C3	FF15	Black Oxide	C3 ~ C7	6002ZZ	EX-STOCK
FF15_C3N		Electroless Nickel Plating	C3 ~ C7	6002VV	EX-STOCK
FF17_C3	FF17	Black Oxide	C3 ~ C7	6203ZZ	EX-STOCK
FF17_C3N		Electroless Nickel Plating	C3 ~ C7	6203VV	EX-STOCK
FF20_C3	FF20	Black Oxide	C3 ~ C7	6204ZZ	EX-STOCK
FF20_C3N		Electroless Nickel Plating	C3 ~ C7	6204VV	EX-STOCK
FF25_C3	FF25	Black Oxide	C3 ~ C7	6205ZZ	EX-STOCK
FF25_C3N		Electroless Nickel Plating	C3 ~ C7	6205VV	EX-STOCK
FF30_C3	FF30	Black Oxide	C3 ~ C7	6206ZZ	EX-STOCK
FF30_C3N		Electroless Nickel Plating	C3 ~ C7	6206VV	EX-STOCK



Black Oxide
(Application : General case)



Electroless Nickel Plating
(Application : Clean room)

Note :

1. It is used double pressed steel cages for Black Oxide type support units .
2. It is used double plastic cages for Electroless Nickel Plating type support units .
3. All of bearings use Japanese & Taiwanese brand bearings.

Support Unit FKA (fixed-side round type)

No.	Part name	Qty
1	Housing	1
2	Bearing	1 set
3	Holding lid	1
4	Collar	2
5	Seal	1~2
6	Lock nut	1set



(FKA06~08)

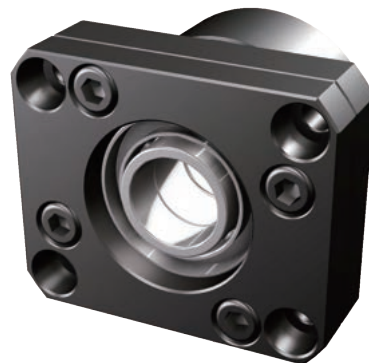

(FKA10~20)

FKA06~FKA20

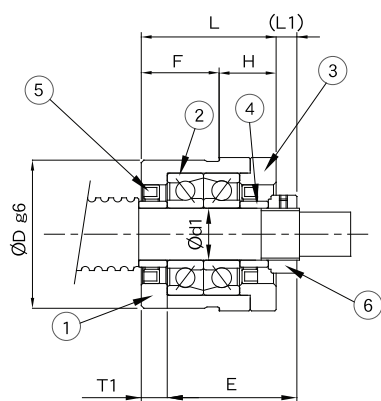

Mounting method A
FKA15H is not applicable

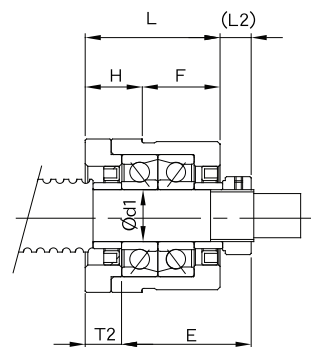
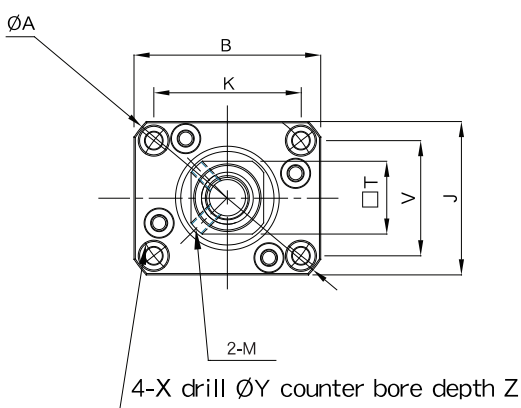

Mounting method B

Unit : mm

Model No.	Shaft diameter d1	L	H	F	E	Dg6	A	B	J	K	V	Mounting method A		Mounting method B		X	Y	Z	M	T	Weight (Kgs)
												L1	T1	L2	T2						
FKA06	6	20	7	13	22	28 -0.007 -0.02	44	36	30	26.79	20.93	5.5	3.5	6.5	4.5	3.4	6.5	4	M3	12	0.14
FKA08	8	23	9	14	26	28 -0.007 -0.02	44	36	30	26.79	20.93	7	4	8	5	3.4	6.5	4	M3	14	0.16
FKA10	10	27	10	17	29.5	36 -0.009 -0.025	56	48	39	35.7	27.39	7.5	5	8.5	6	4.5	8	4	M3	16	0.27
FKA12	12	27	10	17	29.5	36 -0.009 -0.025	56	48	39	35.7	27.39	7.5	5	8.5	6	4.5	8	4	M4	19	0.25
FKA15	15	32	15	17	36	40 -0.009 -0.025	65	56	43	39.4	30.78	10	6	12	8	5.5	9.5	6	M4	22	0.38
FKA15H	15	43	17	26	40	50 -0.009 -0.025	77	63	52	49.64	38.79	4	7	7	10	5.5	9.5	8	M4	22	0.62
FKA20L	20	41	17	24	43	50 -0.009 -0.025	77	63	52	49.64	38.79	9	7	12	10	5.5	9.5	8	M4	30	0.63
FKA20	20	52	22	30	50	57 -0.010 -0.029	86	72	59	56.74	44.33	8	10	12	14	6.6	11	10	M4	30	0.99

Support Unit FKA (fixed-side round type)

Order Code	Model No.	Surface treatment	Applicable ballscrew accuracy grade	Bearing		Delivery date
				Model No.	Max. Starting torque (gf-cm)	
FKA06	FKA06	Black Oxide	C3~C10	706A P5	50	EX-STOCK
FKA06_C5			C5 ~ C10	706A P0	50	3 days
FKA06_C3			C3	706A P5	50	3 days
FKA06_N		Electroless Nickel Plating	C3~C10	706A P5	50	3 days
FKA06_C5N			C5 ~ C10	706A P0	50	3 days
FKA06_C3N			C3	706A P5	50	3 days
FKA08	FKA08	Black Oxide	C3 ~ C10	708A P5	90	EX-STOCK
FKA08_C5			C5 ~ C10	708A P0	90	3 days
FKA08_C3			C3	708A P5	90	3 days
FKA08_N		Electroless Nickel Plating	C3 ~ C10	708A P5	90	EX-STOCK
FKA08_C5N			C5 ~ C10	708A P0	90	3 days
FKA08_C3N			C3	708A P5	90	3 days
FKA10	FKA10	Black Oxide	C3 ~ C10	7000A P5	190	EX-STOCK
FKA10_C5			C5 ~ C10	7000A P0	190	3 days
FKA10_C3			C3	7000A P5	190	3 days
FKA10_N		Electroless Nickel Plating	C3 ~ C10	7000A P5	190	3 days
FKA10_C5N			C5 ~ C10	7000A P0	190	3 days
FKA10_C3N			C3	7000A P5	190	3 days
FKA12	FKA12	Black Oxide	C3 ~ C10	7001A P5	210	EX-STOCK
FKA12_C5			C5 ~ C10	7001A P0	210	EX-STOCK
FKA12_C3			C3	7001A P5	210	3 days
FKA12_N		Electroless Nickel Plating	C3 ~ C10	7001A P5	210	EX-STOCK
FKA12_C5N			C5 ~ C10	7001A P0	210	3 days
FKA12_C3N			C3	7001A P5	210	3 days



(FKA06~FKA08)
Black Oxide
(Application : General case)



(FKA06~FKA08)
Electroless Nickel Plating
(Application : Clean room)

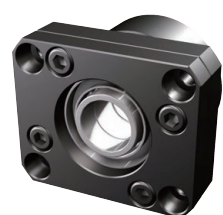

(FKA10~FKA20)
Black Oxide
(Application : General case)

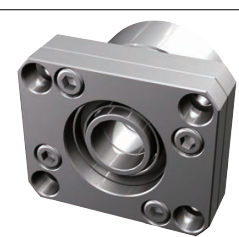

(FKA10~FKA20)
Electroless Nickel Plating
(Application : Clean room)

Note :

1. All types make Preload.
2. All of bearings use Japanese & Taiwanese brand bearings(Model No. in blue), Assembly by DF way. The most suitable way for ballscrew use.

Support Unit FKA (fixed-side round type)

Order Code	Model No.	Surface treatment	Applicable ballscrew accuracy grade	Bearing		Delivery date
				Model No.	Max. Starting torque (gf-cm)	
FKA15	FKA15	Black Oxide	C3 ~ C10	7002A P5	230	EX-STOCK
FKA15_C5			C5 ~ C10	7002A P0	230	3 days
FKA15_C3			C3	7002A P5	230	3 days
FKA15_N		Electroless Nickel Plating	C3 ~ C10	7002A P5	230	EX-STOCK
FKA15_C5N			C5 ~ C10	7002A P0	230	3 days
FKA15_C3N			C3	7002A P5	230	3 days
FKA15H	FKA15H	Black Oxide	C3 ~ C10	7302A P5	380	EX-STOCK
FKA20L	FKA20L	Black Oxide	C3 ~ C10	7004A P5	380	EX-STOCK
FKA20L_C3			C3	7004A P5	380	3 days
FKA20	FKA20	Black Oxide	C3 ~ C10	7204 P5	550	EX-STOCK
FKA20_C5			C5 ~ C10	7204 P0	550	EX-STOCK
FKA20B_C5			C5 ~ C10	7204B P0	550	3 days
FKA20_C3			C3	7204 P5	550	3 days
FKA20_N		Electroless Nickel Plating	C3 ~ C10	7204 P5	550	EX-STOCK
FKA20_C5N			C5 ~ C10	7204 P0	550	3 days
FKA20B_C5N			C5 ~ C10	7204B P0	550	3 days
FKA20_C3N			C3	7204 P5	550	3 days

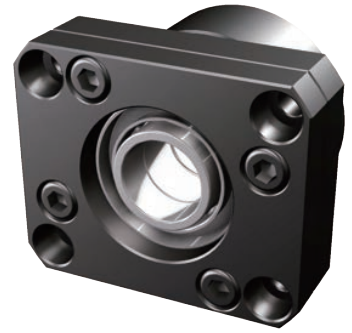

(FKA10~FKA20)
Black Oxide
(Application : General case)



(FKA10~FKA20)
Electroless Nickel Plating
(Application : Clean room)

Note :

1. All types make Preload.
2. All of bearings use Japanese & Taiwanese brand bearings (Model No. in blue), Assembly by DF way. The most suitable way for ballscrew use.

Low profile Support Unit LK
(fixed-side rectangular type)

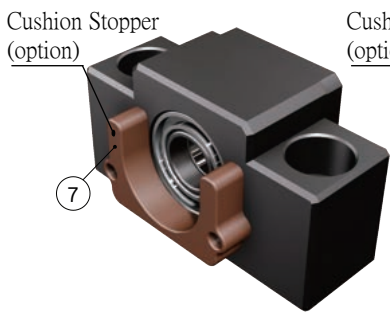
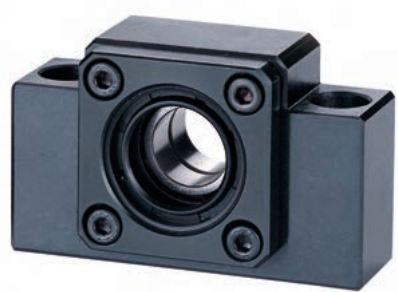
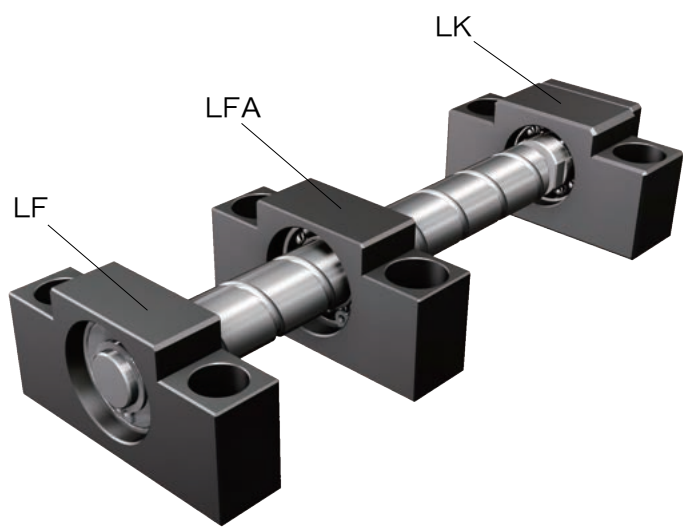

LK10~LK15

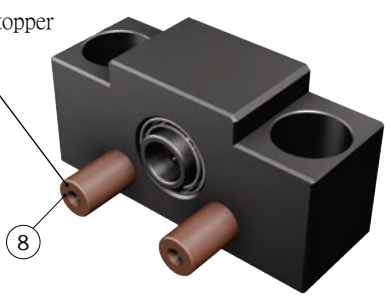

LK08

No.	Part name	Qty
1	Housing	1
2	Bearing	1set
3	Holding lid	1
4	Collar	2
5	Seal	2
6	Lock nut	1set
7	Cushion Stopper (option)	1
8	Cushion Stopper (option)	2

LK

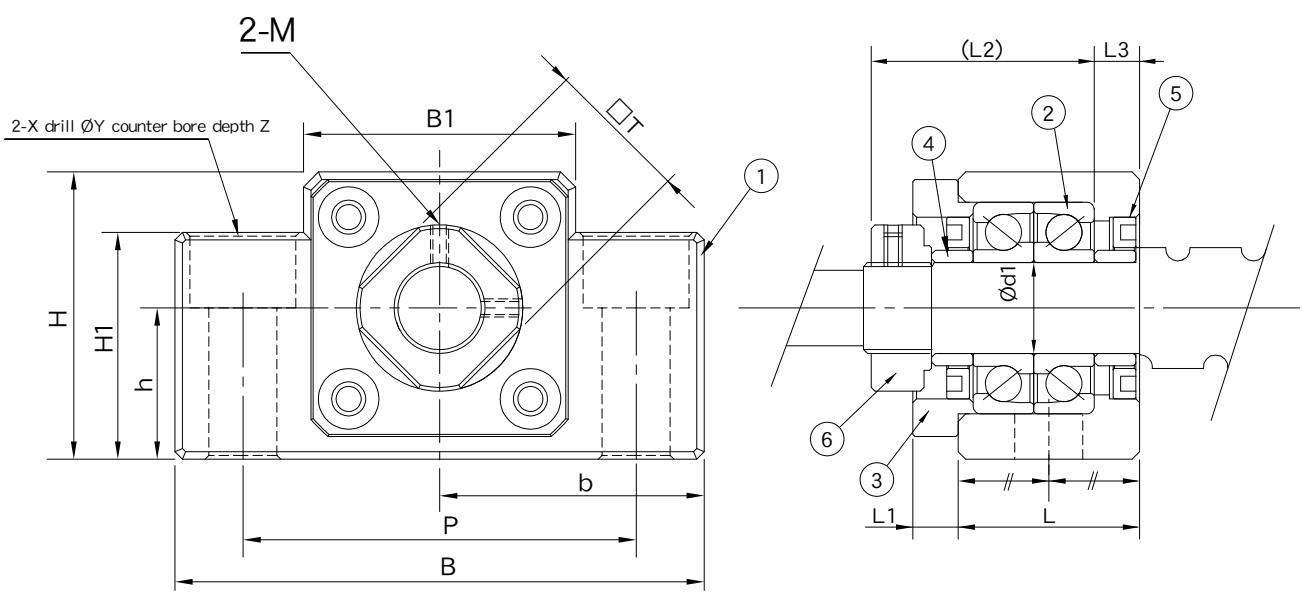

Unit : mm

Model No.	Shaft diameter d1	L	L1	L2	L3	B	H	b		h	B1	H1	P	X	Y	Z	M	T	Weight (Kgs)
								± 0.02	± 0.02										
LK08	8	22.5	-	26	3.5	62	31	31	15.5	30	25.5	46	9	14	12.5	M3	14	0.28	
LK10	10	24	6	29.5	6	70	38	35	20	36	30	52	9	14	10	M3	16	0.44	
LK12	12	24	6	29.5	6	70	38	35	20	36	30	52	9	14	10	M4	19	0.43	
LK15	15	25	6	36	5	80	42	40	22	41	32	60	11	17	13	M4	22	0.53	

Low profile Support Unit LK (fixed-side rectangular type)

Order Coding	Model No.	Surface treatment	Applicable ballscrew accuracy grade	Bearing		Delivery date 
				Model No.	Max.Starting torque (gf-cm)	
LK08	LK08	Black Oxide	C3 ~ C10	708A P5	90	EX-STOCK
LK08_C5			C5 ~ C10	708A P0	90	3 days
LK08_C3			C3	708A P5	90	3 days
LK08_N		Electroless Nickel Plating	C3 ~ C10	708A P5	90	3 days
LK08_C5N			C5 ~ C10	708A P0	90	3 days
LK08_C3N			C3	708A P5	90	3 days
LK10	LK10	Black Oxide	C3 ~ C10	7000A P5	190	EX-STOCK
LK10_C5			C5 ~ C10	7000A P0	190	3 days
LK10_C3			C3	7000A P5	190	3 days
LK10_N		Electroless Nickel Plating	C3 ~ C10	7000A P5	190	3 days
LK10_C5N			C5 ~ C10	7000A P0	190	3 days
LK10_C3N			C3	7000A P5	190	3 days
LK12	LK12	Black Oxide	C3 ~ C10	7001A P5	210	EX-STOCK
LK12_C5			C5 ~ C10	7001A P0	210	3 days
LK12_C3			C3	7001A P5	210	3 days
LK12_N		Electroless Nickel Plating	C3 ~ C10	7001A P5	210	3 days
LK12_C5N			C5 ~ C10	7001A P0	210	3 days
LK12_C3N			C3	7001A P5	210	3 days
LK15	LK15	Black Oxide	C3 ~ C10	7002A P5	230	EX-STOCK
LK15_C5			C5 ~ C10	7002A P0	230	3 days
LK15_C3			C3	7002A P5	230	3 days
LK15_N		Electroless Nickel Plating	C3 ~ C10	7002A P5	230	3 days
LK15_C5N			C5 ~ C10	7002A P0	230	3 days
LK15_C3N			C3	7002A P5	230	3 days



Black Oxide
(Application : General case)



Electroless Nickel Plating
(Application : Clean room)

Note :

1. All types make Preload.
2. All of bearings use Japanese & Taiwanese brand bearings(Model No. in blue), Assembly by DF way. The most suitable way for ballscrew use.

LF

Cushion Stopper
(option)

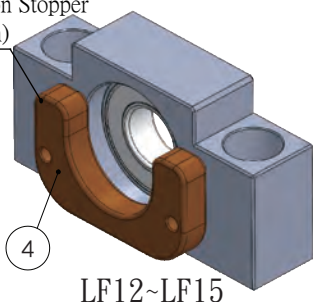

LF12~LF15

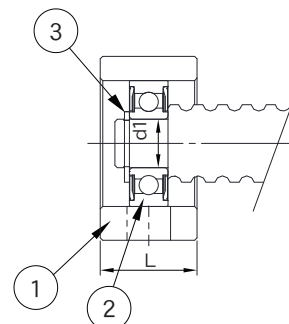
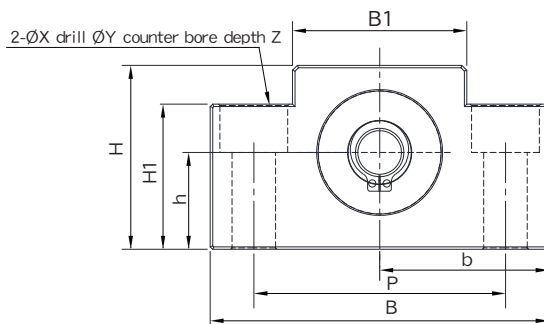

Cushion Stopper
(option)

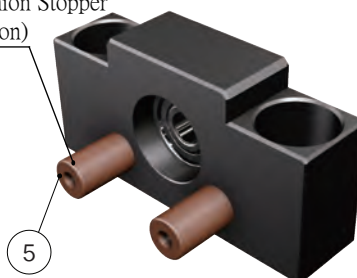

LF08

No.	Part name	Qty
1	Housing	1
2	Bearing	1 set
3	Snap ring	1
4	Cushion Stopper (option)	1
5	Cushion Stopper (option)	2

Unit : mm

Model No.	Shaft diameter d1	L	B	H	b ±0.02	h ±0.02	B1	H1	P	X	Y	Z	Bearing	Snap ring	Weight (Kgs)
LF08	6	16	62	31	31	15.5	30	25.5	46	9	14	12.5	606ZZ	S 06	0.19
LF12	10	20	70	38	35	20	36	30	52	9	14	10	6000ZZ	S 10	0.3
LF15	15	20	80	42	40	22	41	32	60	9	14	11	6002ZZ	S 15	0.36

LFA

Cushion Stopper
(option)

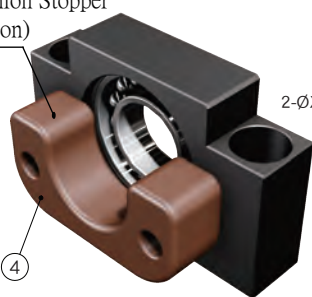

LFA25

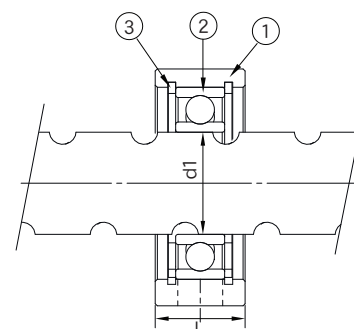
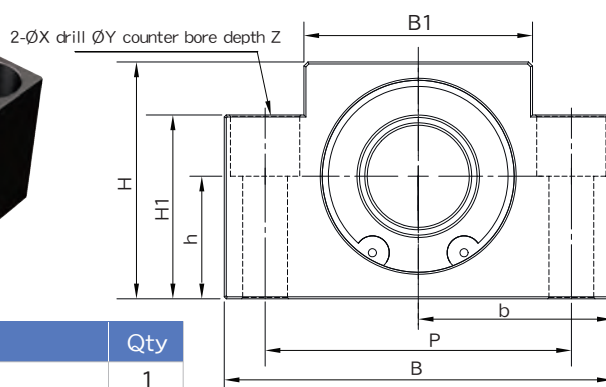

No.	Part name	Qty
1	Housing	1
2	Bearing	1 set
3	Snap ring	2
4	Cushion Stopper (option)	1

Unit : mm

Model No.	Shaft diameter d1	L	B	H	b ±0.02	h ±0.02	B1	H1	P	X	Y	Z	Bearing	Snap ring	Weight (Kgs)
LFA12	12	18	62	31	31	15.5	30	25.5	46	9	14	12.5	6801ZZ	R21	0.2
LFA15	15	18	70	38	35	20	36	30	52	9	14	10	6902ZZ	R28	0.26
LFA20	20	22	80	42	40	22	41	32	60	11	17	13	6804ZZ	R32	0.35
LFA25	25	22	95	58	47.5	30	56	45	75	11	17	15	6005ZZ	R47	0.62

Low profile Support Unit LF/LFA (Supported-side rectangular type)

Order Coding	Model No.	Surface treatment	Applicable ballscrew accuracy grade	Bearing	Delivery date 
LF08_C3	LF08	Black Oxide	C3 ~ C7	606ZZ	EX-STOCK
LF08_C3N		Electroless Nickel Plating	C3 ~ C7	606VV	3 days
LF12_C3	LF12	Black Oxide	C3 ~ C7	6000ZZ	EX-STOCK
LF12_C3N		Electroless Nickel Plating	C3 ~ C7	6000VV	EX-STOCK
LF15_C3	LF15	Black Oxide	C3 ~ C7	6002ZZ	EX-STOCK
LF15_C3N		Electroless Nickel Plating	C3 ~ C7	6002VV	3 days
LFA12_C3	LFA12	Black Oxide	C3 ~ C7	6801ZZ	EX-STOCK
LFA12_C3N		Electroless Nickel Plating	C3 ~ C7	6801ZZ	3 days
LFA15_C3	LFA15	Black Oxide	C3 ~ C7	6902ZZ	EX-STOCK
LFA15_C3N		Electroless Nickel Plating	C3 ~ C7	6902ZZ	3 days
LFA20_C3	LFA20	Black Oxide	C3 ~ C7	6804ZZ	EX-STOCK
LFA20_C3N		Electroless Nickel Plating	C3 ~ C7	6804ZZ	3 days
LFA25_C3	LFA25	Black Oxide	C3 ~ C7	6005ZZ	EX-STOCK
LFA25_C3N		Electroless Nickel Plating	C3 ~ C7	6005ZZ	3 days

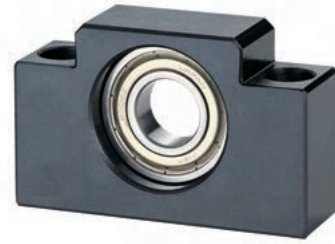

Black Oxide (Application : General case)

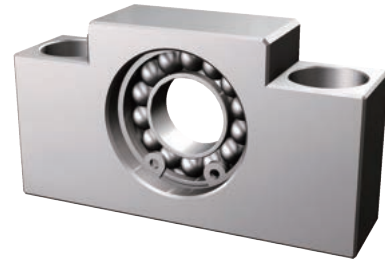

Electroless Nickel Plating
(Application : Clean room)

Note:

1.All of bearings use Japanese & Taiwanese brand bearings.

WBK type support Unit
(heavy-load)



No.	Part name	Qty
1	Housing	1
2	Bearing	1 set
3	Holding lid	1
4	Collar	2
5	Seal	2
6	Lock nut	1 set

WBK

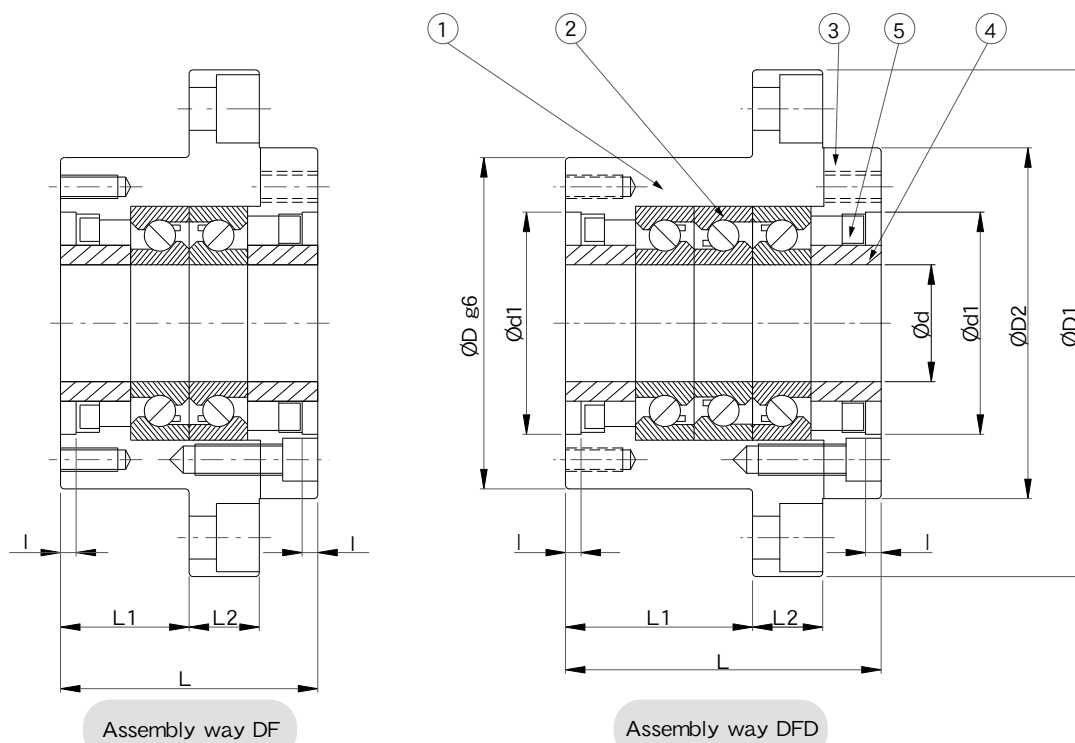

Unit : mm

Model No.	Dimensions of support unit																	
	d	D	D1	D2	L	L1	L2	A	W	X	Y	Z	d1	I	V	P	Q	H
WBK 17DF	17	70	106	72	60	32	15	80	88	9	14	8.5	45	3	58	M5	10	M6
WBK 20DF	20	70	106	72	60	32	15	80	88	9	14	8.5	45	3	58	M5	10	M6
WBK 25DF	25	85	130	90	66	33	18	100	110	11	17	11	57	4	70	M6	12	M6
WBK 25DFD					81	48												
WBK 25DFF					96	48												
WBK 30DF	30	85	130	90	66	33	18	100	110	11	17	11	57	4	70	M6	12	M6
WBK 30DFD					81	48												
WBK 30DFF					96	48												
WBK 35DF	35	95	142	102	66	33	18	106	121	11	17	11	69	4	80	M6	12	M6
WBK 35DFD					81	48												
WBK 35DFF					96	48												
WBK 40DF	40	95	142	102	66	33	18	106	121	11	17	11	69	4	80	M6	12	M6
WBK 40DFD					81	48												
WBK 40DFF					96	48												

Note :

1. Inside bearings use Japanese & Taiwanese P4 grade TAC 60 degree contact ball bearing.
2. The standard type is without H , if required, please advise in advance.

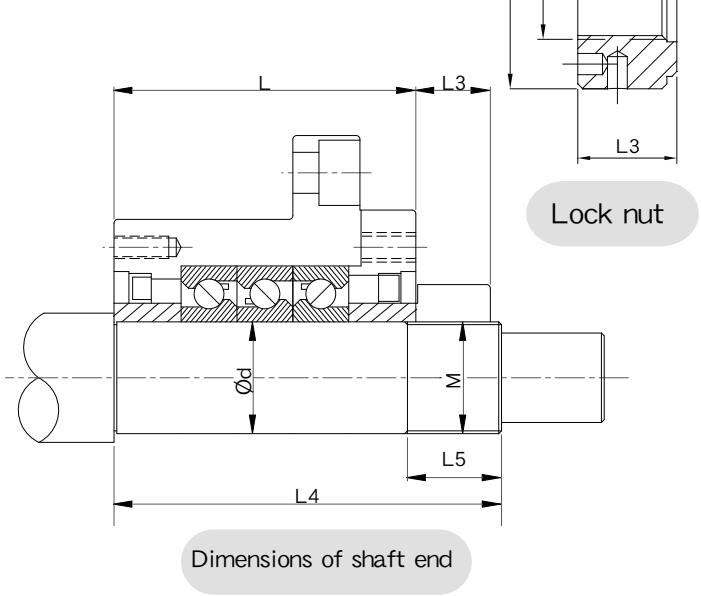
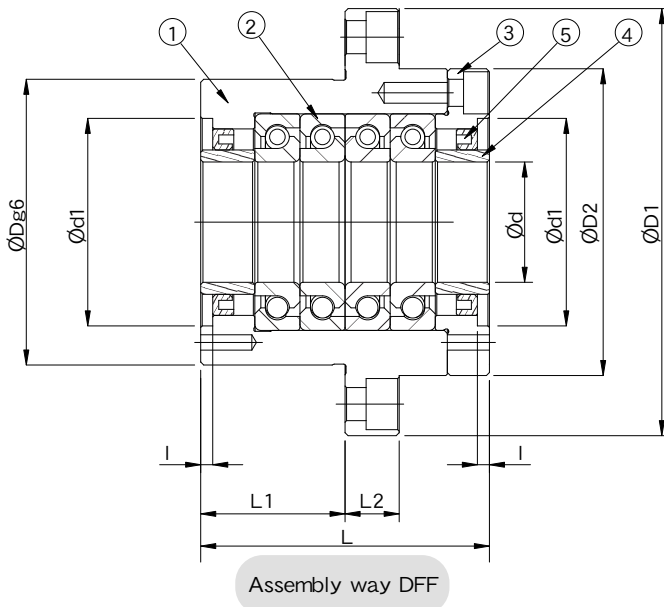
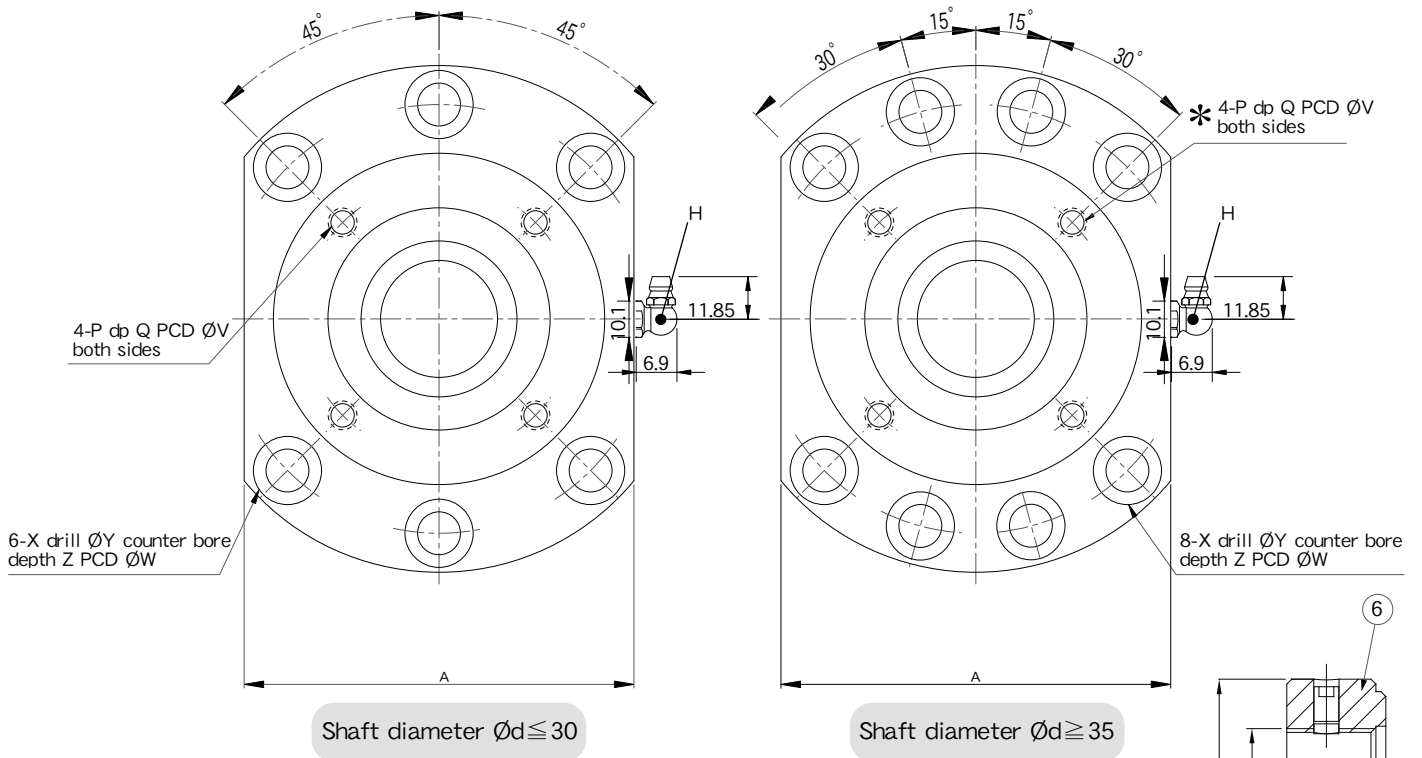

Unit : mm

Model No.	Basic dynamic load rating C_a (N)	limiting axial load (N)	preload (N)	axial rigidity (N/μm)	starting torque (N·cm)	permissible rotational speed (min ⁻¹)	Lock nut			Weight (Kgs)	Dimensions of shaft end		
							M	D3	L3		d	L4	L5
WBK 17DF	23000	26600	1450	630	19	6900	M17X1	36	18	1.99	17 ^{-0.004} _{-0.017}	81	23
WBK 20DF	23000	26600	1450	630	19	6900	M20X1	40	18	1.96	20 ^{-0.005} _{-0.020}	81	23
WBK 25DF	29900	40500	2280	850	28	5200	M25X1.5	45	20	3.28	25 ^{-0.005} _{-0.020}	89	26
WBK 25DFD	48500	81500	3100	1250	39					3.81		104	
WBK 25DFF	48500	81500	4500	1680	49	4900	M30X1.5	50	20	3.71	30 ^{-0.005} _{-0.020}	119	26
WBK 30DF	30500	43000	2400	890	29	4900	M30X1.5	50	20	3.18	30 ^{-0.005} _{-0.020}	89	26
WBK 30DFD	50000	86000	3260	1310	39					3.7		104	
WBK 30DFF	50000	86000	4750	1760	51	4100	M35X1.5	55	22	4.32	35 ^{-0.006} _{-0.025}	119	30
WBK 35DF	32500	50000	2750	1030	33	4100	M35X1.5	55	22	3.79	35 ^{-0.006} _{-0.025}	92	30
WBK 35DFD	53000	100000	3740	1500	41					4.44		107	
WBK 35DFF	53000	100000	5490	2060	52	4100	M40X1.5	60	22	5.21	40 ^{-0.006} _{-0.025}	122	30
WBK 40DF	33500	52000	2860	1080	34	4100	M40X1.5	60	22	3.68	40 ^{-0.006} _{-0.025}	92	30
WBK 40DFD	54000	104000	3900	1590	43					4.29		107	
WBK 40DFF	54000	104000	5730	2150	55	5.03	122	30					

Note :
 3. Dimensions with mark can be used for dust cover and damper installation.
 About its correct position, please contact SYK.

SBK type support Unit
(heavy-load)

No.	Part name	Qty
1	Housing	1
2	Bearing	1 set
3	Holding lid	1
4	Collar	2
5	Seal	2
6	Lock nut	1 set

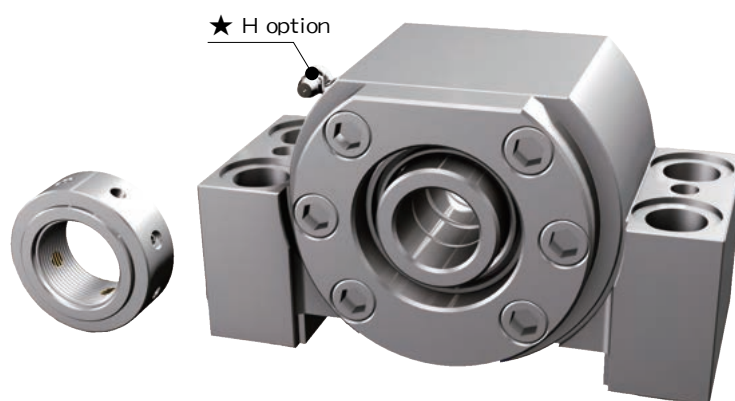

SBK

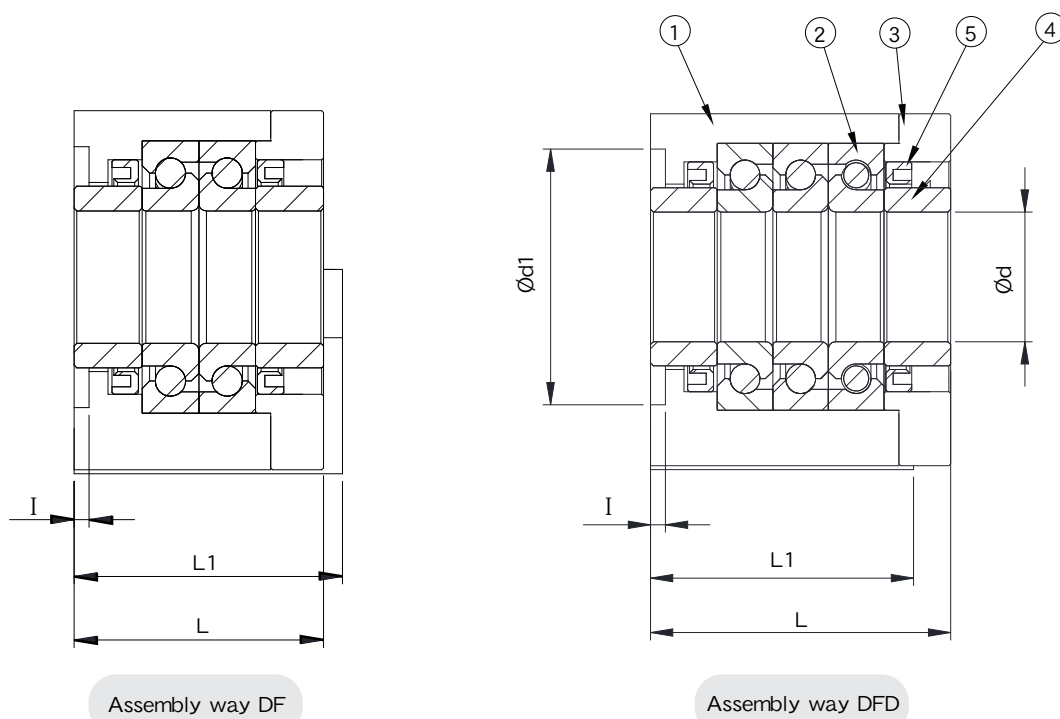

Unit : mm

Model No.	Dimensions of support unit																			Supported side	
	d	A	$\frac{h}{\pm 0.02}$	H1	L	L1	L3	B	d1	E	C2	C1	X	Y	Z	I	V	P	Q		H
SBK 25DF	25	89	51	53	66	71	18	160	57	130	15.5	40	18	26	2	4	70	M6	10	M6	SF25
SBK 25DFD					81																
SBK 30DF	30	89	51	53	66	71	18	160	57	130	15.5	40	18	26	2	4	70	M6	10	M6	BF30
SBK 30DFD					81																
SBK 35DF	35	96	52	54	66	71	18	160	69	130	15.5	40	18	26	2	4	80	M6	10	M6	BF35
SBK 35DFD					81																
SBK 40DF	40	96	52	54	66	71	18	160	69	130	15.5	40	18	26	2	4	80	M6	10	M6	SF40
SBK 40DFD					81																

Note :

1. Inside bearings use Japanese & Taiwanese P4 grade TAC 60 degree contact ball bearing.
2. The standard type is without H , if required, please advise in advance.

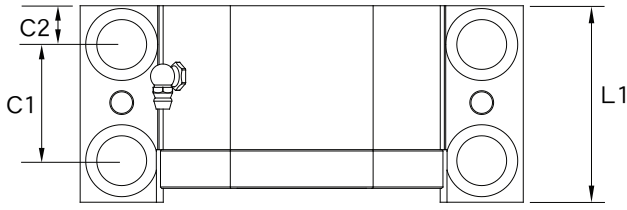

DF

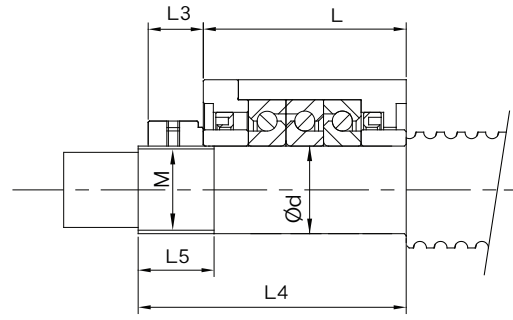

Dimensions of shaft end



DFD

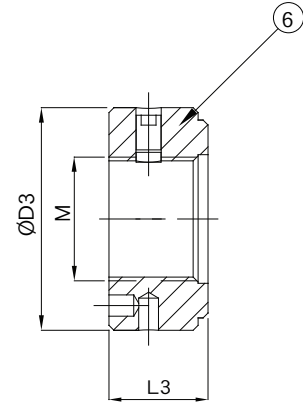

Lock nut

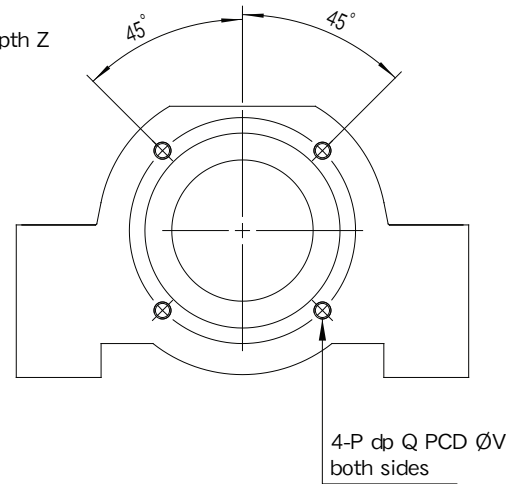
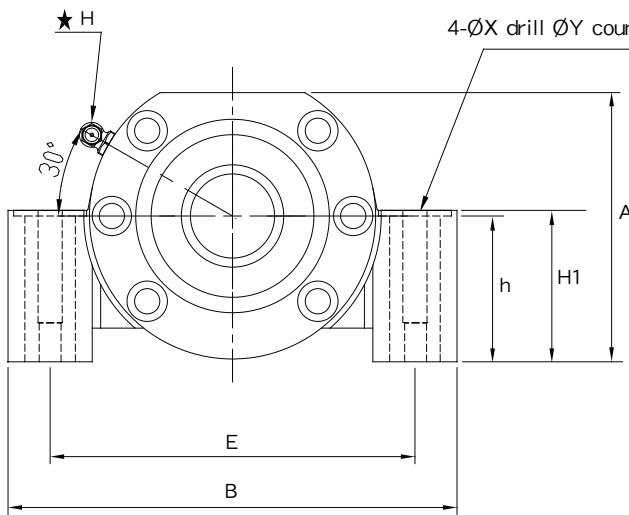

Unit : mm

Model No.	Basic dynamic load rating Ca (N)	limiting axial load (N)	preload (N)	axial rigidity (N/µm)	starting torque (N·cm)	permissible rotational speed (min ⁻¹)	Lock nut			Weight (Kgs)	Dimensions of shaft end		
							M	D3	L3		d	L4	L5
SBK 25DF	29900	40500	2280	850	28	5200	M25X1.5	45	20	4.47	25 ^{-0.005} _{-0.020}	89	26
SBK 25DFD	48500	81500	3100	1250	39					5.22		104	
SBK 30DF	30500	43000	2400	890	29	4900	M30X1.5	50	20	4.44	30 ^{-0.005} _{-0.020}	89	26
SBK 30DFD	50000	86000	3260	1310	39					5.11		104	
SBK 35DF	32500	50000	2750	1030	33	4100	M35X1.5	55	22	4.58	35 ^{-0.006} _{-0.025}	92	30
SBK 35DFD	53000	100000	3740	1500	41					5.33		107	
SBK 40DF	33500	52000	2860	1080	34	4100	M40X1.5	60	22	4.51	40 ^{-0.006} _{-0.025}	92	30
SBK 40DFD	54000	104000	3900	1590	43					5.18		107	

MBK type support Unit
(heavy-load)



No.	Part name	Qty
1	Housing	1
2	Bearing	1 set
3	Holding lid	1
4	Collar	2
5	Seal	2
6	Lock nut	1 set

MBK

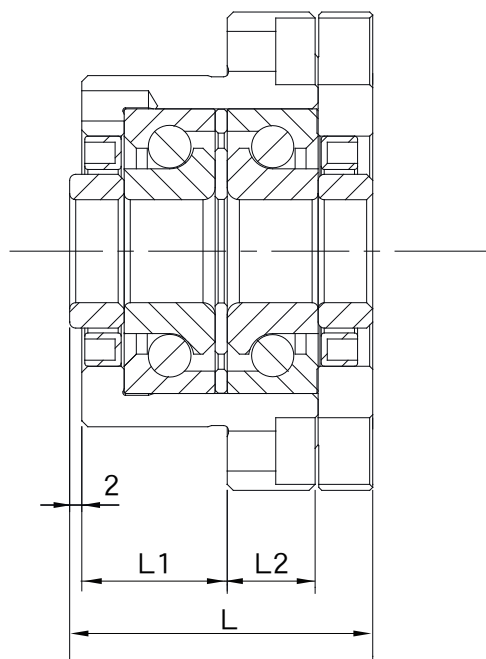

Assembly way DF

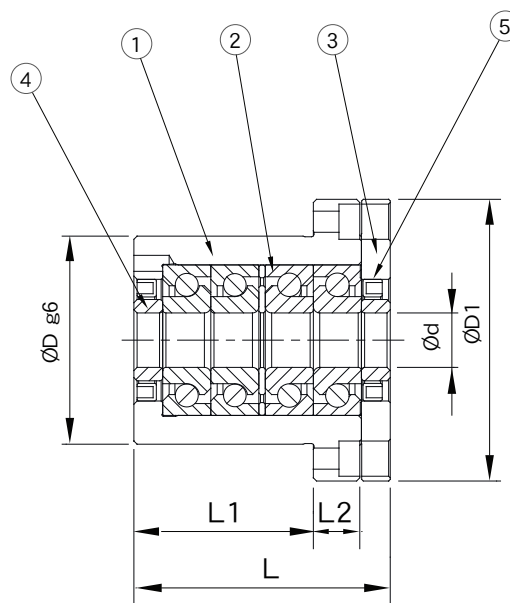

Assembly way DFF

Unit : mm

Model No.	Dimensions of support unit											
	d	D	D1	L	L1	L2	A	W	X	Y	Z	H
MBK 15DF - G	15	58	79	50	24	14.5	79	66	6.6	11	7	M6
MBK 17DF - G	17	58	79	50	24	14.5	79	66	6.6	11	7	M6
MBK 17DFF - G		65	88	80	56		88	74				
MBK 20DF - G	20	58	79	50	24	14.5	79	66	6.6	11	7	M6
MBK 20DFF - G		65	88	80	56		88	74				

Note :

1. Inside bearings use Japanese & Taiwanese P4 grade TAC 60 degree contact ball bearing.

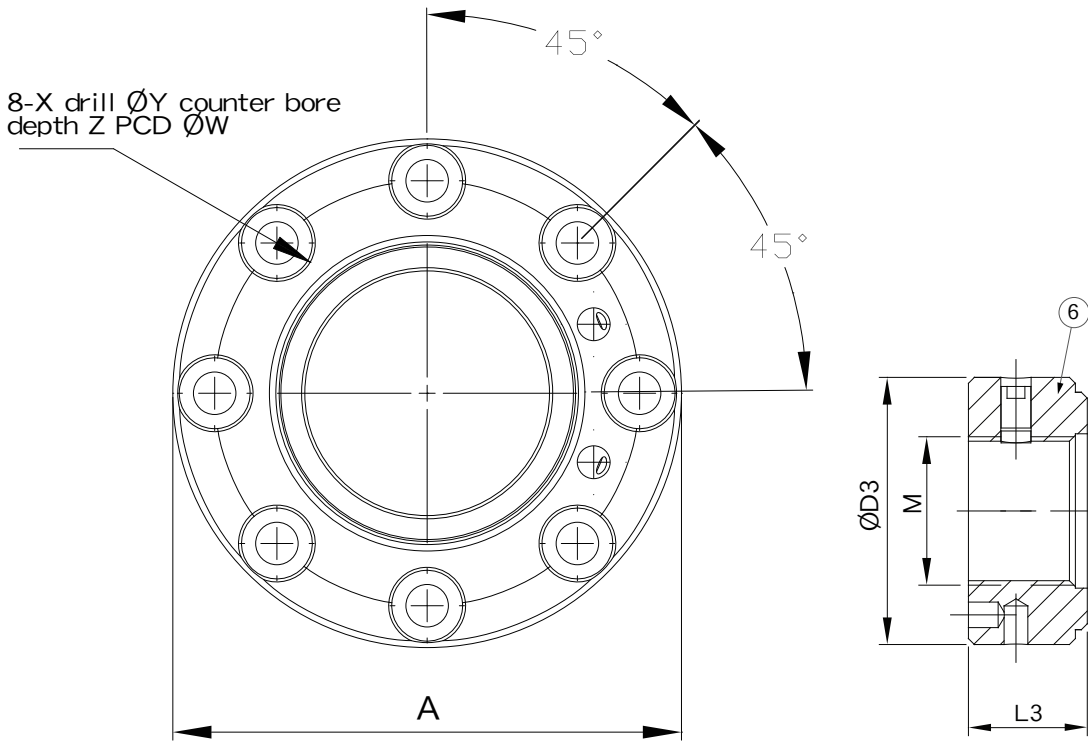

Shaft diameter $\text{Ø}d \leq 20$

Lock nut

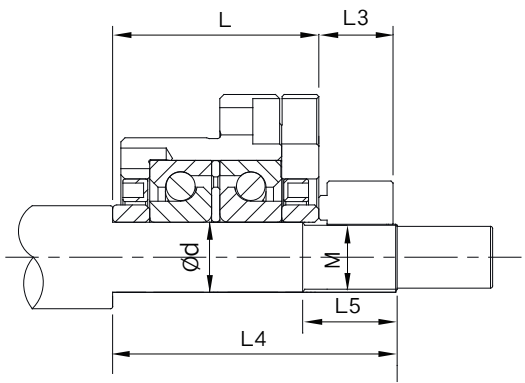

DF
Dimensions of shaft end

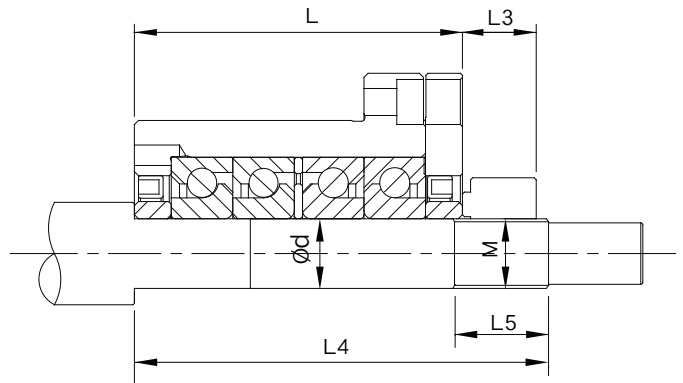

DFF
Dimensions of shaft end

Unit : mm

Model No.	Basic dynamic load rating C_a (N)	limiting axial load (N)	preload (N)	axial rigidity (N/ μ m)	starting torque (N · cm)	permissible rotational speed (min ⁻¹)	Lock nut			Weight (Kgs)	Dimensions of shaft end		
							M	D3	L3		d	L4	L5
MBK 15DF	21900	26600	1000	555	19	7600	M15X1	-	-	1.44	15 ^{-0.004} _{-0.017}	69	23
MBK 17DF	23000	26600	1450	630	19	6900	M17X1	37	18	1.44	17 ^{-0.004} _{-0.017}	69	23
MBK 17DFF	47500	53500	2010	920	32					1.7		101	
MBK 20DF	23000	26600	1450	630	19	6900	M20X1	40	18	1.22	20 ^{-0.005} _{-0.020}	69	23
MBK 20DFF	47500	53500	2010	920	32					2.22		101	

Lock Nut

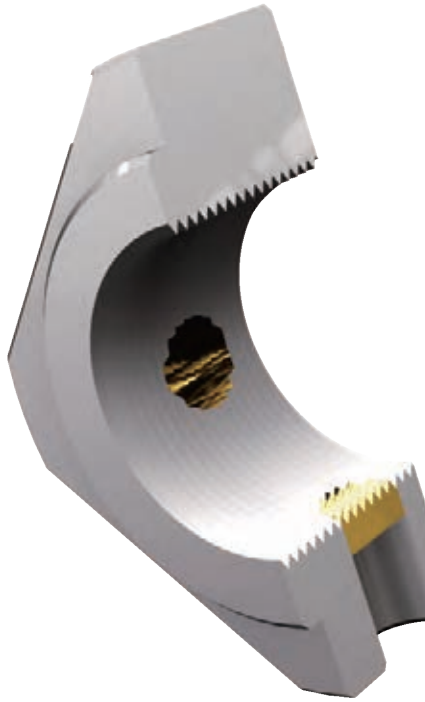

No.	Part name	Qty
1	Lock nut	1 set

Lock Nut

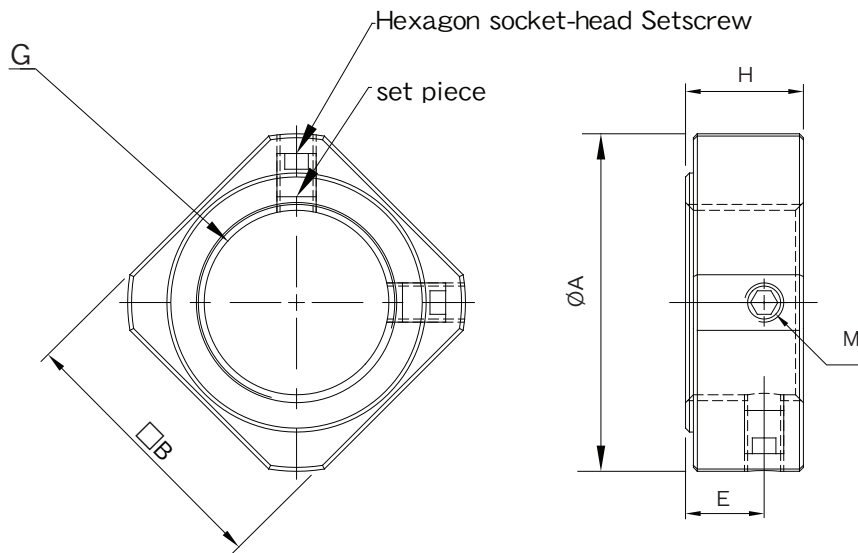

Unit : mm

Unit : mm

Model No.		A	E	H	M	B	G
RN05 RN05_N	5	12.5	2.7		M3x0.5	11	M5x0.5
RN06 RN06_N	5	13.5	2.7		M3x0.5	12	M6x0.75
RN08 RN08_N	6.5	16.4	4		M3x0.5	14	M8x1.0
RN10 RN10_N	8	19	5.5		M3x0.5	16	M10x1.0
RN12 RN12_N	8.1	22.8	5.1		M4x0.7	19	M12x1.0
RN15 RN15_N	8	25.8	4.75		M4x0.7	22	M15x1.0

Model No.		A	H	M	B	E	G
RN17 RN17_N	13	29	9	M4	24		M17x1.0
RN20 RN20_N	11	35	7	M4	30		M20x1.0
RN25 RN25_N	15	43	10	M6	35		M25x1.5
RN30 RN30_N	20	48	14	M6	40		M30x1.5
RN35 RN35_N	21	60	14	M6	50		M35x1.5
RN40 RN40_N	25	62	18	M6	50		M40x1.5

Lock Nut (Heavy-load)



No.	Part name	Qty
1	Lock nut	1 set

Lock Nut (Heavy-load)

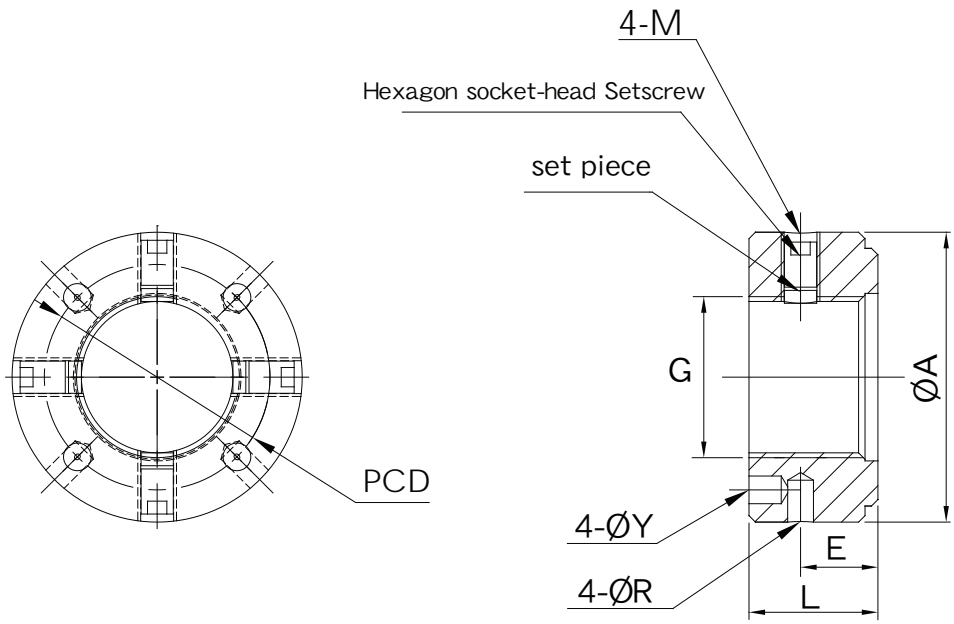

SPANNER

Unit : mm

Model No.	L	E	A	M	Y	R	PCD	G	SPANNER
RN17W RN17W_N	18	10	36	M6	4.3	4	27	M17x1.0	ZL017
RN20W RN20W_N	18	10	40	M6	4.3	4	30	M20x1.0	ZL020
RN25W RN25W_N	20	11	45	M6	4.3	5	35	M25x1.5	ZL025
RN30W RN30W_N	20	11	50	M6	4.3	5	40	M30x1.5	ZL025
RN35W RN35W_N	22	12	55	M6	4.3	5	45	M35x1.5	ZL035
RN40W RN40W_N	22	12	60	M6	4.3	5	50	M40x1.5	ZL040

Lock Nut

Order Coding	Model No.	Surface treatment	MAX.Torque (kgf-cm)	Setscrew MAX.Torque (kgf-cm)	
RN05	M5*PO.5	Black Oxide	15	6(M3)	 <p>Black Oxide (Application : General case)</p>
RN05_N		Electroless Nickel Plating			
RN06	M6*PO.75	Black Oxide	20	6(M3)	
RN06_N		Electroless Nickel Plating			
RN08	M8*P1.0	Black Oxide	25	6(M3)	
RN08_N		Electroless Nickel Plating			
RN10	M10*P1.0	Black Oxide	30	6(M3)	
RN10_N		Electroless Nickel Plating			
RN12	M12*P1.0	Black Oxide	65	15(M4)	 <p>Electroless Nickel Plating (Application : Clean room)</p>
RN12_N		Electroless Nickel Plating			
RN15	M15*P1.0	Black Oxide	80	15(M4)	
RN15_N		Electroless Nickel Plating			
RN17	M17*P1.0	Black Oxide	95	15(M4)	
RN17_N		Electroless Nickel Plating			
RN17W	M17*P1.0 (Heavy-load)	Black Oxide	420	50(M6)	
RN17W_N		Electroless Nickel Plating			
RN20	M20*P1.0	Black Oxide	170	15(M4)	<p>Heavy-load</p>  <p>Black Oxide (Application : General case)</p>
RN20_N		Electroless Nickel Plating			
RN20W	M20*P1.0 (Heavy-load)	Black Oxide	460	50(M6)	
RN20W_N		Electroless Nickel Plating			
RN25	M25*P1.5	Black Oxide	210	50(M6)	
RN25_N		Electroless Nickel Plating			
RN25W	M25*P1.5 (Heavy-load)	Black Oxide	870	50(M6)	
RN25W_N		Electroless Nickel Plating			
RN30	M30*P1.5	Black Oxide	320	50(M6)	<p>Heavy-load</p>  <p>Electroless Nickel Plating (Application : Clean room)</p>
RN30_N		Electroless Nickel Plating			
RN30W	M30*P1.5 (Heavy-load)	Black Oxide	1050	50(M6)	
RN30W_N		Electroless Nickel Plating			
RN35	M35*P1.5	Black Oxide	480	50(M6)	
RN35_N		Electroless Nickel Plating			
RN35W	M35*P1.5 (Heavy-load)	Black Oxide	1450	50(M6)	
RN35W_N		Electroless Nickel Plating			
RN40	M40*P1.5	Black Oxide	720	50(M6)	
RN40_N		Electroless Nickel Plating			
RN40W	M40*P1.5 (Heavy-load)	Black Oxide	1600	50(M6)	
RN40W_N		Electroless Nickel Plating			

Recommended shaft end shape (Fixed-side) for Support Units types BK

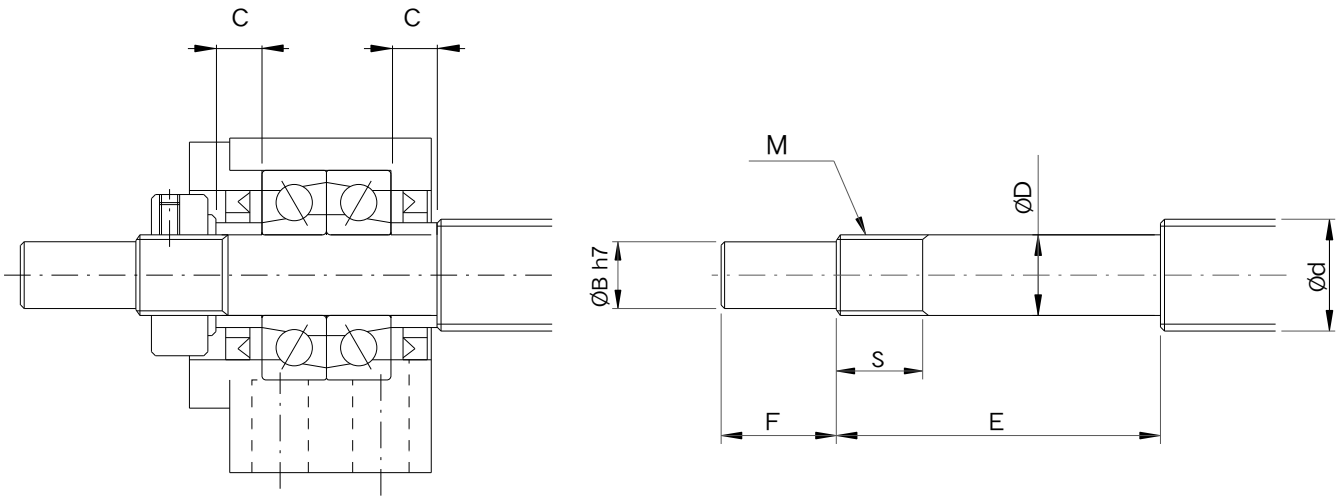

Type BK

Unit : mm

Support unit model No.	Ball screw shaft OD	Shaft support portion OD				Metric screw thread	Length of Sleeve	
Type BK	d	D	B	E	F	M	S	C
BK10	12/14/15	10 -0.008 -0.015	8	36	15	M10×1	12	5.5
BK12	14/15/16	12 -0.008 -0.017	10	36	15	M12×1	12	5.5
BK15	18/20	15 -0.008 -0.017	12	40	20	M15×1	12	6
BK17	20/25	17 -0.008 -0.017	15	53	23	M17×1	17	7
BK20	25/28	20 -0.010 -0.020	17	53	25	M20×1	15	8
BK25	32/36	25 -0.010 -0.020	20	66	30	M25×1.5	20	9
BK30	36/40	30 -0.010 -0.020	25	73	38	M30×1.5	25	9
BK35	45	35 -0.012 -0.025	30	82	45	M35×1.5	26	12
BK40	50	40 -0.012 -0.025	35	94	50	M40×1.5	30	15

Recommended shaft end shape (Fixed-side) for Support Units types FK,FKA,EK,AK,LK

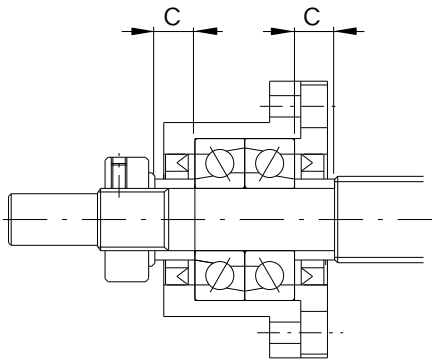
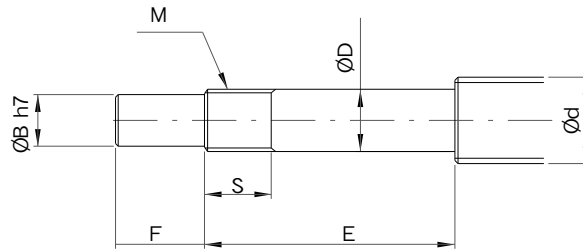

Type FK,FKA

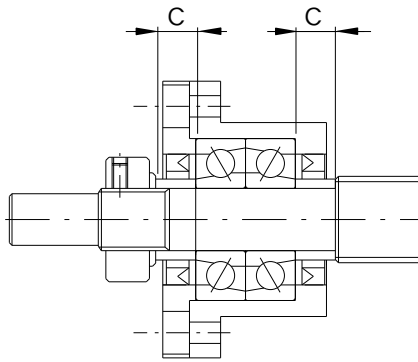

Type FK,FKA

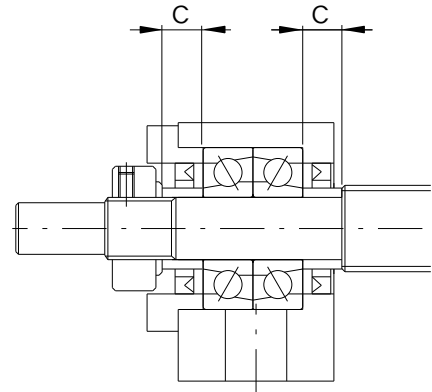

Type EK,AK,LK

Unit : mm

Support unit model No.				Ball screw shaft OD	Shaft support portion OD				Metric screw thread	Length of Sleeve	
Type FK,FKA	Type EK	Type AK	Type LK	d	D	B	E	F	M	S	C
FK05	EK05	-	-	8	5 -0.008 -0.015	4	23	6	M5x0.5	7	3.5
FK06 FKA06	EK06	-	-	8	6 -0.008 -0.015	4	28	8	M6x0.75	8	5
FK08 FKA08	EK08	-	LK08	10/12	8 -0.008 -0.015	6	32	9	M8x1	10	5.5
FK10 FKA10	EK10	AK10	LK10	12/14/15	10 -0.008 -0.015	8	36	15	M10x1	12	5.5
FK12 FKA12	EK12	AK12	LK12	14/15/16	12 -0.008 -0.017	10	36	15	M12x1	12	5.5
FK15 FKA15	EK15	AK15	LK15	18/20	15 -0.008 -0.017	12	48	20	M15x1	13	10
FKA15H											6
FK17	-	-	-	20/25	17 -0.008 -0.017	15	59	23	M17x1	17	10
FK20 FKA20	EK20 SK20	AK20	-	25/28/30	20 -0.010 -0.020	17	64	25	M20x1	16	11
FKA20L							53			15	8
FK25	-	AK25	-	30/32/36	25 -0.010 -0.020	20	76	30	M25x1.5	20	14
FK30	-	-	-	36/40	30 -0.010 -0.020	25	73	38	M30x1.5	25	9

Recommended shaft end shape (Supported-side) for Support Units types FF,EF,BF,AF,LF

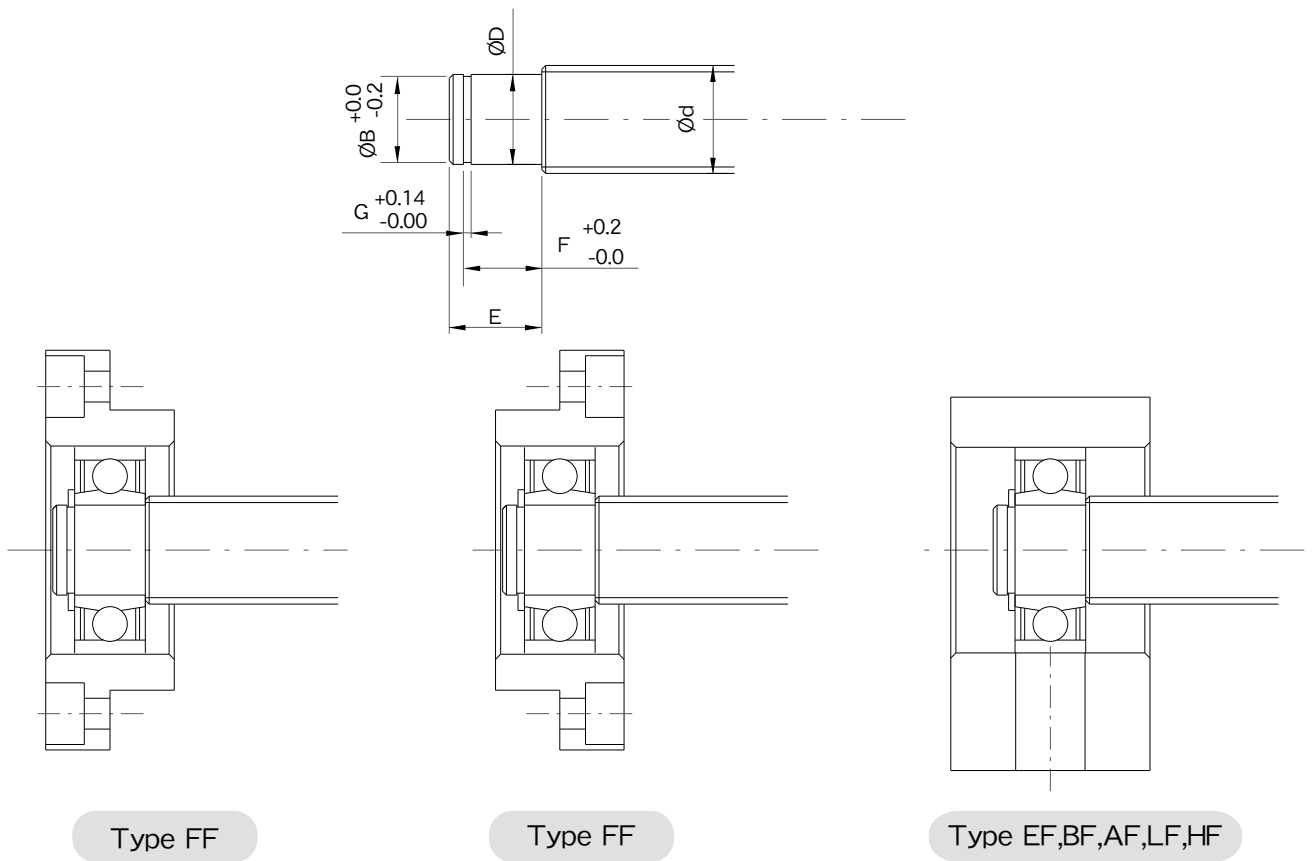

Unit : mm

Support unit model No.					Ballscrew shaft OD	Shaft support portion OD					
Type FF	Type EF	Type BF	Type AF	Type LF	d	D	E	B	F	G	
FF06	EF06	-	-	-	8	6 -0.008 -0.015	9	5.7	6.8	0.8	
-	EF08	-	-	LF08	10	6 -0.008 -0.015	9	5.7	6.8	0.8	
FF10	EF10	BF10	AF10	-	12/14/15	8 -0.008 -0.015	10	7.6	7.9	0.9	
FF12	EF12	BF12	AF12	LF12	14/15/16	10 -0.008 -0.015	11	9.6	9.15	1.15	
FF15	EF15	BF15	AF15	LF15	18/20	15 -0.008 -0.017	13	14.3	10.15	1.15	
FF17	-	BF17	-	-	20/25	17 -0.008 -0.017	16	16.2	13.15	1.15	
-	-	BF20	-	-	25/28/30	20 -0.010 -0.020	16	19	13.35	1.35	
FF20	EF20 SF20	-	AF20	-			19		15.35		
FF25	-	BF25/SF25	AF25	-	30/32/36	25 -0.010 -0.020	20	23.9	16.35	1.35	
FF30	-	BF30	-	-	36/40	30 -0.010 -0.020	21	28.6	17.75	1.75	
-	-	BF35	-	-	40/45	35 -0.012 -0.025	22	33	18.75	1.75	
-	-	BF40/SF40	-	-	50	40 -0.012 -0.025	23	38	19.95	1.95	

Note : Shaft end machining of HF same as BF.

Recommended shaft end shape (Heavy-load)

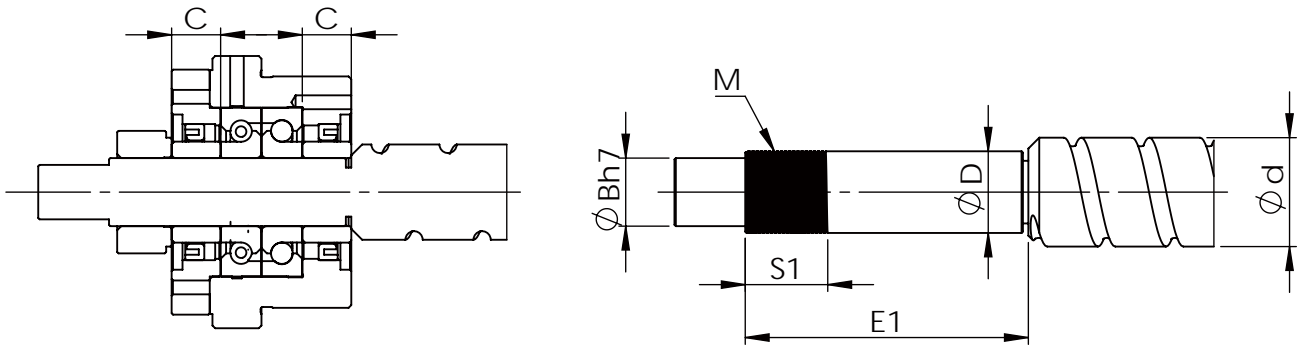

Unit : mm

model No.	Ballscrew shaft OD	Shaft support portion OD	B	E1	Metric screw thread		Length of Sleeve
	d	D			M	S1	C
WBK17 DF	20/25	17 ^{-0.004} / _{-0.017}	15	81	M17x1	23	15
WBK20 DF	25/28	20 ^{-0.005} / _{-0.020}	17		M20x1		
WBK25 DF	32/36	25 ^{-0.005} / _{-0.020}	20	89	M25x1.5	26	18
WBK25 DFD				104			
WBK25 DFF				119			
WBK30 DF	36/40	30 ^{-0.005} / _{-0.020}	25	89	M30x1.5	26	18
WBK30 DFD				104			
WBK30 DFF				119			
WBK35 DF	45	35 ^{-0.006} / _{-0.025}	30	92	M35x1.5	30	18
WBK35 DFD				107			
WBK35 DFF				122			
WBK40 DF	50	40 ^{-0.006} / _{-0.025}	35	92	M40x1.5	30	18
WBK40 DFD				107			
WBK40 DFF				122			
MBK15 DF	18/20	15 ^{-0.004} / _{-0.017}	12	69	M15x1	23	9
MBK17 DF	20/25	17 ^{-0.004} / _{-0.017}	15		M17x1		
MBK17 DFF				101			
MBK20 DF	25/28	20 ^{-0.005} / _{-0.020}	17	69	M20x1	23	9
MBK20 DFF				101			
SBK25 DF	32/36	25 ^{-0.005} / _{-0.020}	20	89	M25x1.5	26	18
SBK25 DFD				104			
SBK30 DF	36/40	30 ^{-0.005} / _{-0.020}	25	89	M30x1.5	26	18
SBK30 DFD				104			
SBK35 DF	45	35 ^{-0.006} / _{-0.025}	30	92	M35x1.5	30	18
SBK35 DFD				107			
SBK40 DF	50	40 ^{-0.006} / _{-0.025}	35	92	M40x1.5	30	18
SBK40 DFD				107			

Ballscrew support unit equivalent interchangeable for major manufacturer

SYK & THK
BK10
BK12
BK15
BK17
BK20
BK25
BK30
BK35
BK40

SYK & THK	KURODA	NSK	MISUMI
EK05	-	-	-
EK06	BUK-6	WBK06-01A	BSW06
EK08	BUK-8F	WBK08-01A	BSW08
EK10	-	-	-
EK12	-	-	-
EK15	-	-	-
EK20	-	-	-

SYK & THK	KURODA	NSK	MISUMI
FK05	-	-	-
FK06	-	WBK06-11	BRW06
FK08	BUM-8	WBK08-11	BRW08
FK10	BUM-10	WBK10-11	BRW10
FK12	BUM-12	WBK12-11	BRW12
FK15	BUM-15	WBK15-11	BRW15
FK17	-	-	-
FK20	BUM-20	WBK20-11	BRW20
FK25	BUM-25	WBK25-11	BRW25
FK30	-	-	-

BF10
BF12
BF15
BF17
BF20
BF25
BF30
BF35
BF40

EF06	-	-	BUN06
EF08	BUK-6S	WBK08S-01	BUN08
EF10	-	-	BUN10
EF12	-	-	BUN12
EF15	-	-	-
EF20	-	-	BUN20

FF06	-	-	BUR06
FF10	-	-	BUR10
FF12	-	-	BUR12
FF15	-	-	BUR15
FF17	-	-	-
FF20	-	-	BUR20
FF25	-	-	BUR25
FF30	-	-	-

SYK	KURODA	NSK	MISUMI
AK10	BUK-10F	WBK10-01A	BSW10
AK12	BUK-12F	WBK12-01A	BSW12
AK15	BUK-15F	WBK15-01A	BSW15
BK17	-	WBK17-01A	-
AK20	BUK-20F	WBK20-01	BSW20
AK25	BUK-25F	WBK25-01	BSW25

SYK	NSK
WBK 17DF	WBK 17DF-31
WBK 20DF	WBK 20DF-31
WBK 25DF	WBK 25DF-31
WBK 25DFD	WBK 25DFD-31
WBK 30DF	WBK 30DF-31
WBK 30DFD	WBK 30DFD-31
WBK 35DF	WBK 35DF-31
WBK 35DFD	WBK 35DFD-31
WBK 40DF	WBK 40DF-31
WBK 40DFD	WBK 40DFD-31

SYK	NSK	PMI
LK08	WBK08-01B	-
LK10	WBK10-01B	-
LK12	WBK12-01B	PBKN12
LK15	WBK15-01B	PBKN15
AK20	WBK20-01	PBKN20
LF08	WBK08S-01B	-
LF12	WBK12S-01B	-
LF15	WBK15S-01B	-
LFA12	WBK12SF-01	PBFN12
LFA15	WBK15SF-01	PBFN15
LFA20	WBK20SF-01	PBFN20
LFA25	WBK25SF-01	PBFN25

AF10	BUK-8S	WBK10S-01	-
AF12	BUK-10S	WBK12S-01	-
AF15	BUK-15S	WBK15S-01	-
BF17	-	WBK17S-01	-
AF20	BUK-20S	WBK20S-01	-
AF25	BUK-25S	WBK25S-01	BUN25

Nut Bracket MC



MC

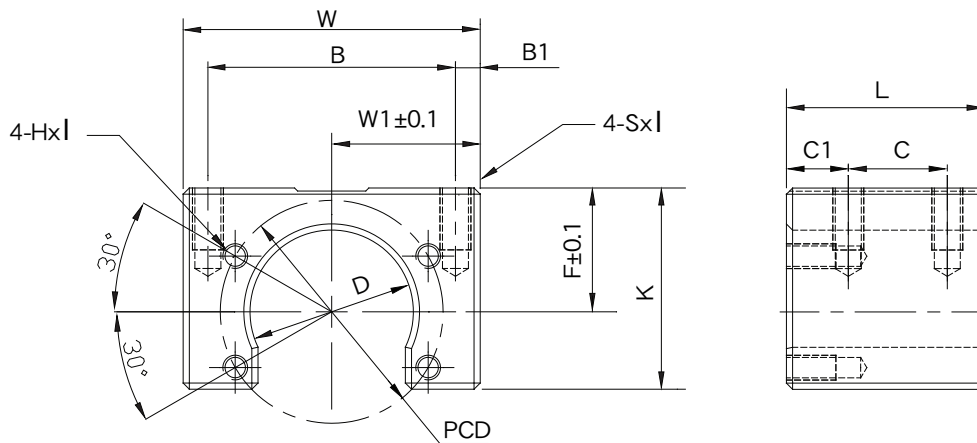

Unit : mm

Model No.	Width W	W1	B	B1	Overall Length L	C	C1	F	K	D	PCD	SxI	HxI	Far factory automation equipment Supported Ball Screw models	Weight (Kgs)
MC 1004	48	24	40	4	32	16	10	20	32.5	26.4	36	M5×10	M4×7	BNK1004、BNK1005	0.27
MC 1205	60	30	47	6.5	36	24	6	21	37	30.4	40	M6×12	M4×7	BNK1205	0.41
MC 1408	60	30	50	5	36	20	10	21.5	37	34.4	45	M6×12	M5×8	BNK1408、BNK1510 BNK1520、BNK1616	0.37
MC 2010	86	43	70	8	50	30	10	31	54	46.4	59	M10×20	M6×10	BNK2010	1.1
MC 2020	86	43	70	8	40	24	8	28	51	39.4	59	M10×20	M6×10	BNK2020	0.89

Application table of MC Nut bracket for ballscrew manufacturer.

Model NO.	Ballscrew manufacturer					
	THK	NSK	HIWIN	PMI	COMTOP	GTEN
MC 1004	BNK1004,BNK1005	W1004 FA,	R1004FSW	FSIW1404,FSIC1403 FSIC1404,FSIC1405		FSI1404,FSI1405
MC1205	BNK1205 BNK1205	W1205 FA,W1210 FA	R1205FSW,R1210FSW	FSWW1204 ,FSWC1204/05 FSWC1210,PTR1205/10/20	XSVR1210	FSC1210
MC 1408	BNK1408,BNK1510 BNK1520,BNK1616	W1405 FA,W1408 FA W1510 FA,W1520 FA W1616 FA,W1632 FA	R1405FSW,R1408FSW FSW1510,R1510DFSH R1520DFSH,R1520FSH,R1632DFSH	FSIC2005/06,FSWC1405 FSWC1510,FSKC1520 PTR1505/10/20	SFI 1610,SFI 2004 SFI 2005 XSVR1510,XSVR1520	FSI1610,FSI2005 FSC1520
MC 2010	BNK2010	W2010 FA,W2020 FA	R2010FSW,R2020FSW	FSWC2010,PTR2010	XSVR2010,XSVR2020	FSC2010
MC 2020	BNK2020		R 2020DFSH			

Nut Bracket MGD



MGD

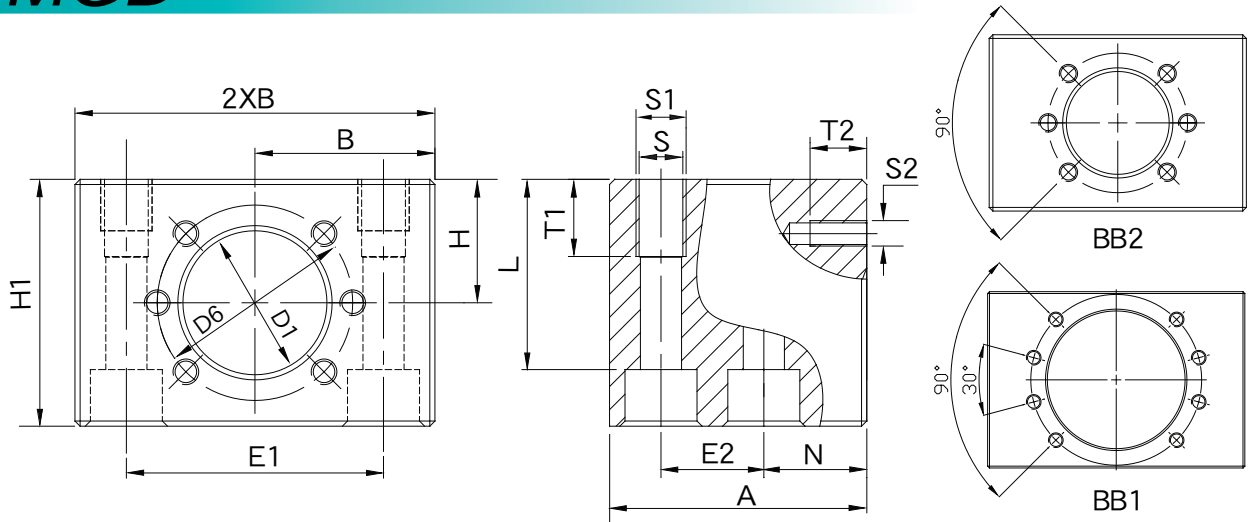

Unit : mm

Model No.	Size	$d_0 \times P$	Part number	$D1 \pm 0.1$	$D6$	A	$B \pm 0.1$	$H \pm 0.1$	H1	E1	E2	N	S	S1	T1	S2	T2	ISO4762	L	Weight (Kgs)																
MGD 16L	16x5	16x10	1506-0-0050	28.4	38	36	28	20	39	46±0.1	20±0.1	8	-	M6	12	M5	10	BB2	-	-	0.45															
MGD 16	16x16	50				35	24	48	50±0.1			20	8.4	M10	15		M8		37	0.99																
MGD 20L	20x5	20x20	1506-1-0050	36.4	47	55	37.5	23	48	55±0.1	23±0.1	22	8.4	M10	15	M6	11	BB2	-	-	1.12															
MGD 20								28	54										8.4	M10	15	M8	45	1.21												
MGD 25	25x5	25x10	1506-2-0050	40.4	51	55	40	30	58	60±0.1	23±0.1	22	8.4	M10	15	M6	11	BB2	M8	49	1.35															
MGD 32S	25x25	32x10						35	68										70±0.1	45±0.1	12.5	-	M12	20	M8	14	BB2	-	-	2.23						
MGD 32	32x5	32x10	1506-3-0050	50.4	65	70	50	35	68	75±0.1	30±0.1	27	13	M16	20	M8	14	BB2	M12	52	2.27															
MGD 40	32x20	32x32																	27	13	M16	20	M8	14	BB2	M12	52	2.27								
MGD 40	40x5	40x10	1506-4-0050	63.4	78	80	60	42	84	90±0.1	35±0.1	31	15	M18	25	M8	17	BB1	M14	66	3.8															
	40x12	40x16																																		
	40x20	40x40																																		

Application table of MGD Nut bracket for ballscrew manufacturer.

Model No.	Ballscrew manufacturer				
	STAR	HIWIN	PMI	COMTOP	GTEN
MGD 16	1502,1512-0-****	FSI-16-05	FSIN-16-05	SFU 1605	FSU 1605
MGD 20	1502,1512-1-****	FSI-20-05	FSIN-20-05	SFU 2005	FSU 2005
MGD 25	1502,1512-2-****	FSI-25-05	FSIN-25-05	SFU 2505	FSU 2505
		FSI-25-10	FSIN-25-10	SFU 2510	FSU 2510
MGD 32	1502,1512-3-****	FSI-32-05	FSIN-32-05	SFU 3205	FSU 3205
		FSI-32-10	FSIN-32-10	SFU 3210	FSU 3210
MGD 40	1502,1512-4-****	FSI-40-05	FSIN-40-05	SFU 4005	FSU 4005
		FSI-40-10	FSIN-40-10	SFU 4010	FSU 4010

SGS-C DISK/CLAMP TYPE//SHORTER FLEXIBLE COUPLING

Features :

- Suitable for servo-motor and precision transmission mechanism.
- Single disk , compact design ,low moment of inertia and zero backlash.
- Allow minor deviation in angularity and end -play.
- Fixed method: Clamp type. Material: Aluminum alloy.

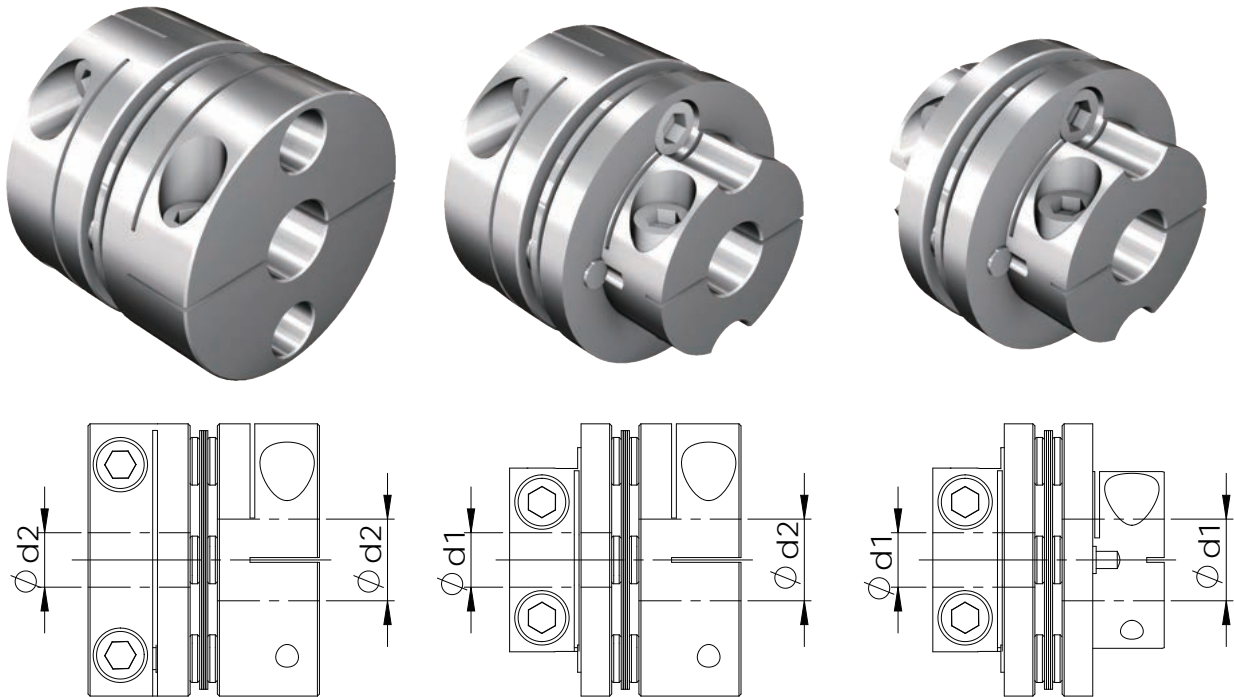

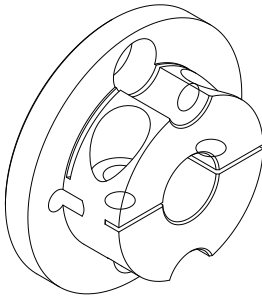
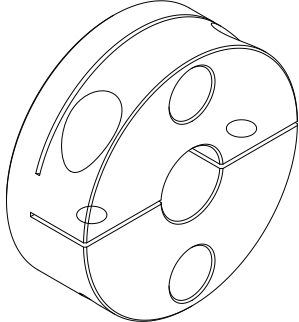
Model No.	$\phi d1$	$\phi d2$
Figure.		
SGS27C	4 ~ 6.35	7 ~ 10
SGS34C	6 ~ 9.525	10 ~ 14
SGS40C	8 ~ 10	11 ~ 16
SGS45C	10 ~ 13	14 ~ 19
SGS50C	10 ~ 16	17 ~ 22
SGS57C	12 ~ 18	19 ~ 24
SGS65C	12 ~ 21	22 ~ 28

SGS-C DISK/CLAMP TYPE// SHORTER FLEXIBLE COUPLING

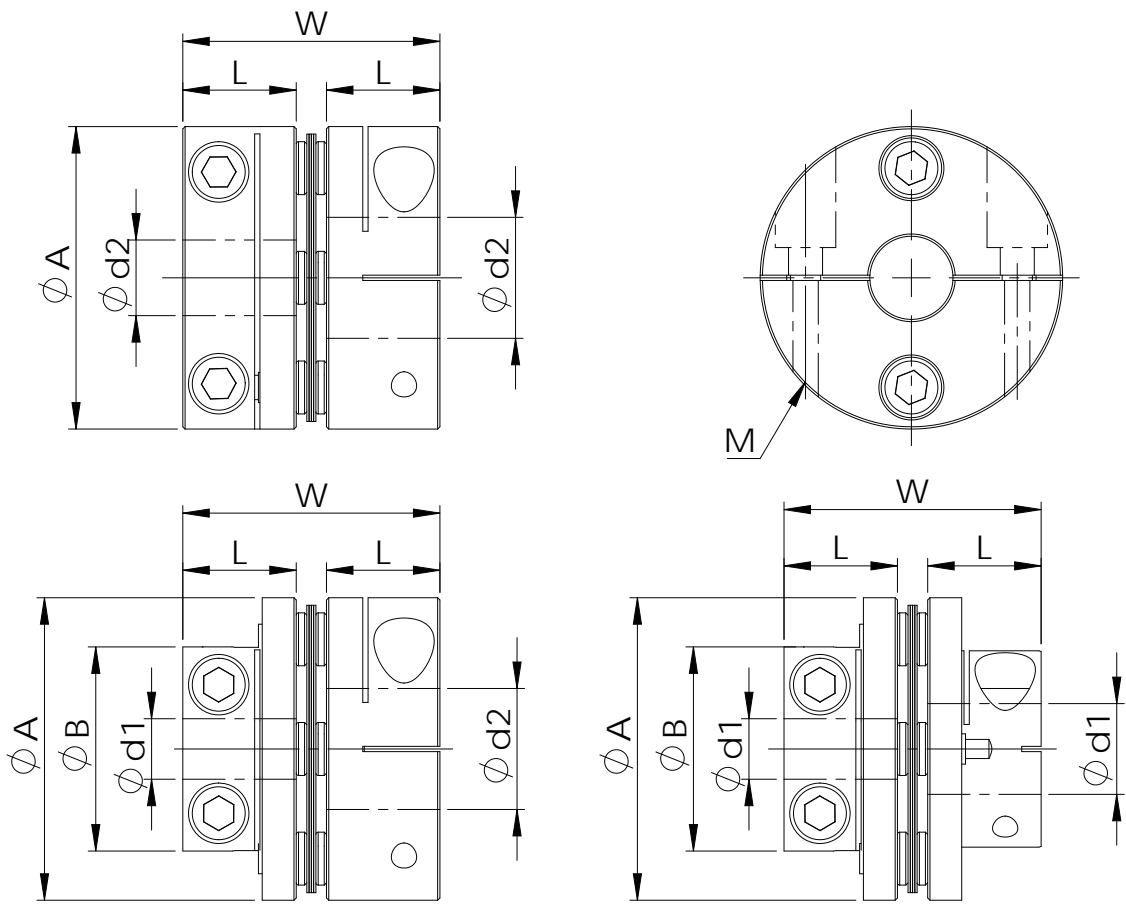

Dimension

Catalog Number	φ A	φ B	L	W	φ d1 x φ d2		Setscrew Max. torque.	
					Stock bores. (H8)		M	kgf-cm
					φ d1	φ d2		
SGS-27C	27	20	11	24.5	4 ~ 6.35	7 ~ 10	4 - M3	20
SGS-34C	34	23	12	27	6 ~ 9.525	10 ~ 14	4 - M3	20
SGS-40C	40	27	15	34	8 ~ 10	11 ~ 16	4 - M4	35
SGS-45C	45	34	15	34	10 ~ 13	14 ~ 19	4 - M4	35
SGS-50C	50	40	20	45	10 ~ 16	17 ~ 22	4 - M5	75
SGS-57C	57	45	20	45	12 ~ 18	19 ~ 24	4 - M5	75
SGS-65C	65	50	24	54	12 ~ 21	22 ~ 28	4 - M6	100

Specifications

Catalog Number	Rated Torque (N . m)	Max Torque (N . m)	Max Rotational Frequency (min-1)	Moment of Inertia (Kg.m2)	Errors of Eccentricity (mm)	Errors of Angularity (°)	Errors of Shaft End-Play (mm)	Weight (kgs)
SGS-27C	2	4	10000	3.1x10 ⁻⁶	0.02	1°	±0.15	0.05
SGS-34C	5	10		8.0x10 ⁻⁶			±0.2	0.07
SGS-40C	7	14		2.0x10 ⁻⁵			±0.25	0.12
SGS-45C	10	20		2.8x10 ⁻⁵			±0.3	0.15
SGS-50C	16	32		6.6x10 ⁻⁵			±0.35	0.24
SGS-57C	26	52		9.8x10 ⁻⁵			±0.4	0.3
SGS-65C	60	120		24.0x10 ⁻⁵			±0.45	0.46

SGL-C DISK/CLAMP TYPE//LONGER FLEXIBLE COUPLING

Features :

- Suitable for servo-motor and precision transmission mechanism.
- double disks , low moment of inertia and zero backlash.
- Allow minor deviation in eccentricity , angularity and end -play.
- Fixed method: Clamp type. Material: Aluminum alloy.

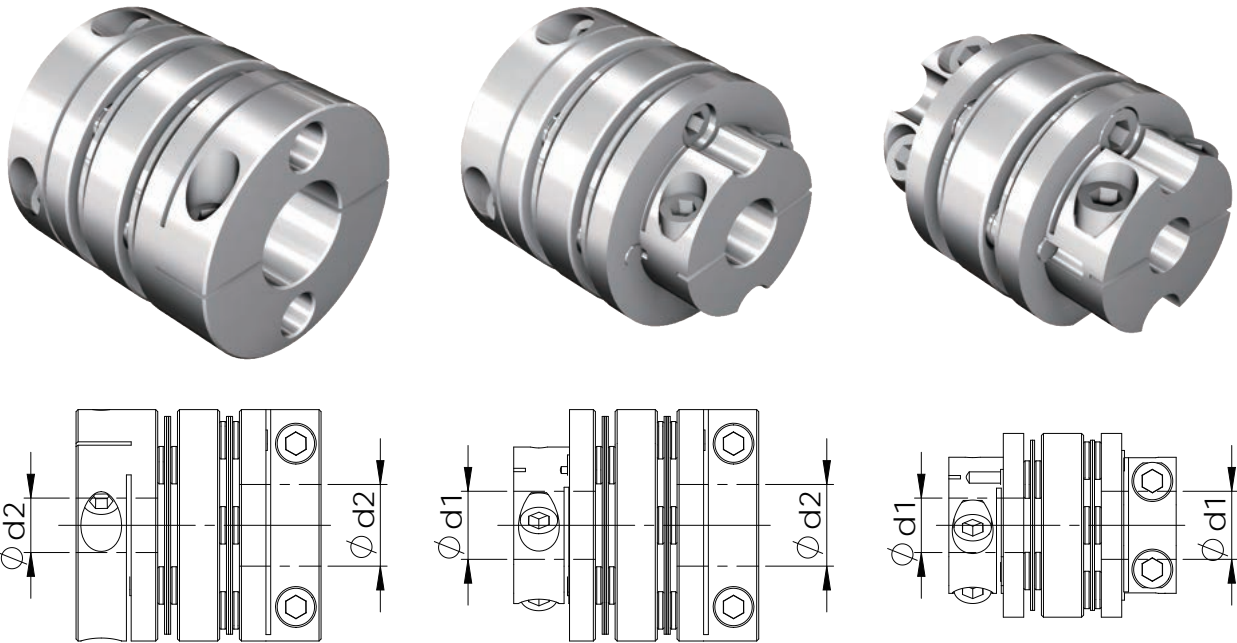

Model No.	ϕ d1	ϕ d2
Figure.		
SGL27C	4 ~ 6.35	7 ~ 10
SGL34C	6 ~ 9.525	10 ~ 14
SGL40C	8 ~ 10	11 ~ 16
SGL45C	10 ~ 13	14 ~ 19
SGL50C	10 ~ 16	17 ~ 22
SGL57C	12 ~ 18	19 ~ 24
SGL65C	12 ~ 21	22 ~ 28

SGL-C DISK/CLAMP TYPE//LONGER FLEXIBLE COUPLING

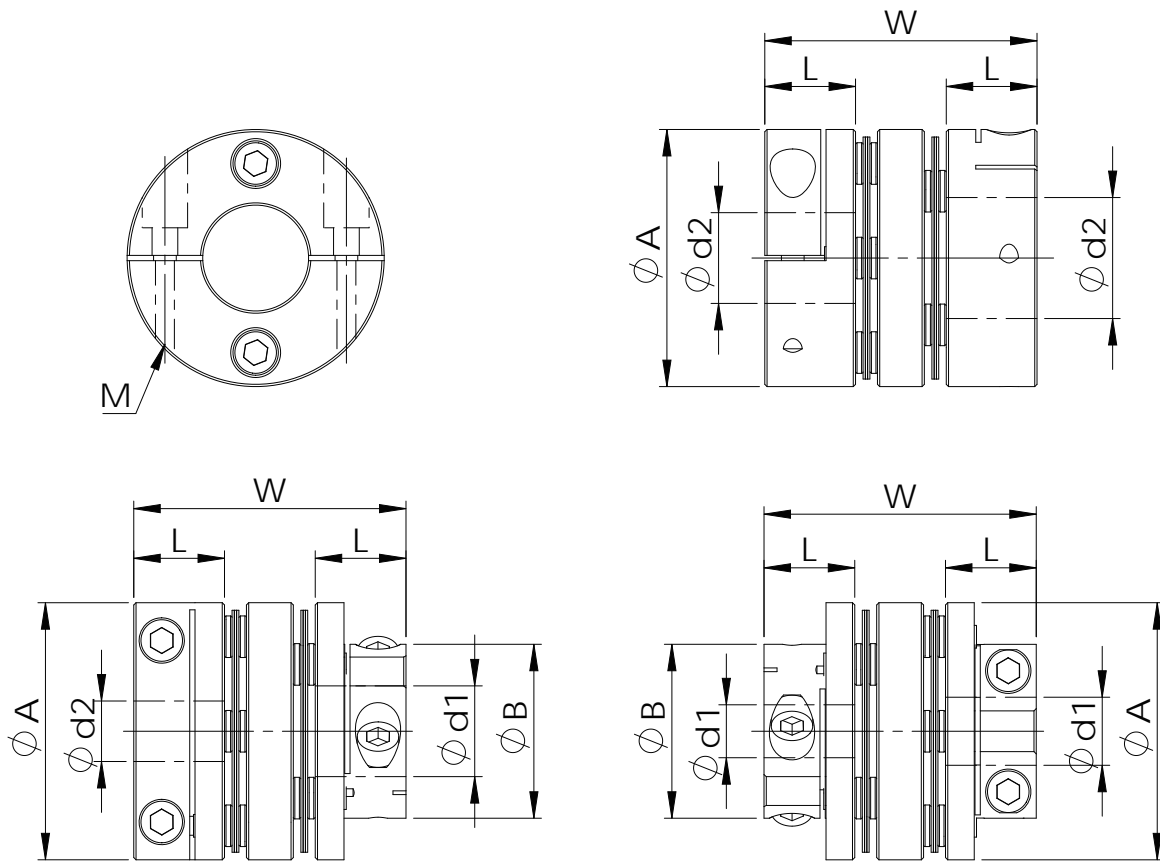

Dimension

Catalog Number	ϕA	ϕB	L	W	$\phi d1 \times \phi d2$		Setscrew Max. torque.	
					Stock bores. (H8)		M	kgf-cm
					$\phi d1$	$\phi d2$		
SGL-27C	27	20	11	33.5	4 ~ 6.35	7 ~ 10	4 - M3	20
SGL-34C	34	23	12	36	6 ~ 9.525	10 ~ 14	4 - M3	20
SGL-40C	40	27	15	46	8 ~ 10	11 ~ 16	4 - M4	35
SGL-45C	45	34	15	46	10 ~ 13	14 ~ 19	4 - M4	35
SGL-50C	50	40	20	59	10 ~ 16	17 ~ 22	4 - M5	75
SGL-57C	57	45	20	59	12 ~ 18	19 ~ 24	4 - M5	75
SGL-65C	65	50	24	71	12 ~ 21	22 ~ 28	4 - M6	100

Specifications

Catalog Number	Rated Torque (N . m)	Max Torque (N . m)	Max Rotational Frequency (min-1)	Moment of Inertia (Kg.m ²)	Errors of Eccentricity (mm)	Errors of Angularity (°)	Errors of Shaft End-Play (mm)	Weight (kgs)
SGL-27C	2	4	10000	4.7x10 ⁻⁶	0.15	2°	±0.33	0.06
SGL-34C	5	10		1.4x10 ⁻⁵	0.17		±0.4	0.09
SGL-40C	7	14		3.1x10 ⁻⁵	0.22		±0.5	0.16
SGL-45C	10	20		4.8x10 ⁻⁵	0.22		±0.6	0.19
SGL-50C	16	32		9.8x10 ⁻⁵	0.24		±0.7	0.29
SGL-57C	26	52		16.2x10 ⁻⁵	0.27		±0.8	0.38
SGL-65C	60	120		40x10 ⁻⁵	0.35		±0.9	0.57

SX15 / SXY15 Ball Screw Actuator

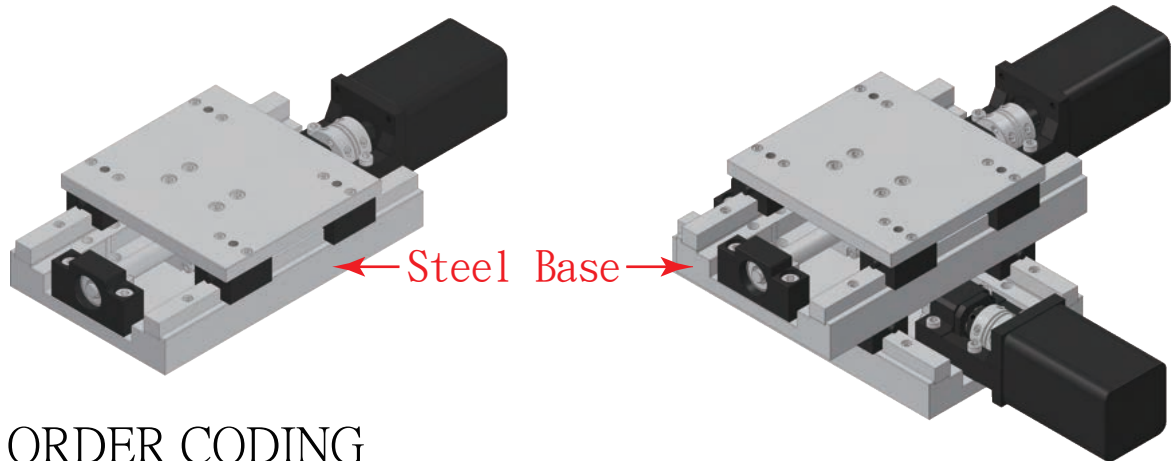

ORDER CODING

S X Y 15 - 05 05 P

AXIS		Table Size	
SX	Single Axis	15	150mm
SXY	Two Axis		

X-axis Stroke		Y-axis Stroke		Accuracy Grade	
05	50mm	05	50mm	P	Precision Class
10	100mm	10	100mm	R	Standard Class
15	150mm	15	150mm		
		20	200mm		
		25	250mm		
		30	300mm		
		40	400mm		
		50	500mm		
		60	600mm		
		70	700mm		
		80	800mm		

Specification of Single Axis

Model no.	Table Size (W * L)	Stroke
SX15-05P	150x160mm	±25
SX15-10P		±50
SX15-15P		±75
SX15-20P		±100
SX15-25P		±125
SX15-30P		±150
SX15-40P		±200
SX15-50P		±250
SX15-60P		±300
SX15-70P		±350
SX15-80P		±400

Specification of Two Axis

Model no.	Table Size (W * L)	Stroke	
		X-axis	Y-axis
SXY15-0505P	150x160mm	±25	±25
SXY15-0510P		±25	±50
SXY15-0515P		±25	±75
SXY15-1010P		±50	±50
SXY15-1015P		±50	±75
SXY15-1515P		±75	±75
SXY15-1520P		±75	±100
SXY15-1525P		±75	±125
SXY15-1530P		±75	±150
SXY15-1540P		±75	±200
SXY15-1550P		±75	±250
SXY15-1560P		±75	±300
SXY15-1570P		±75	±350
SXY15-1580P		±75	±400

SX15 Single Axis Ball Screw Actuator

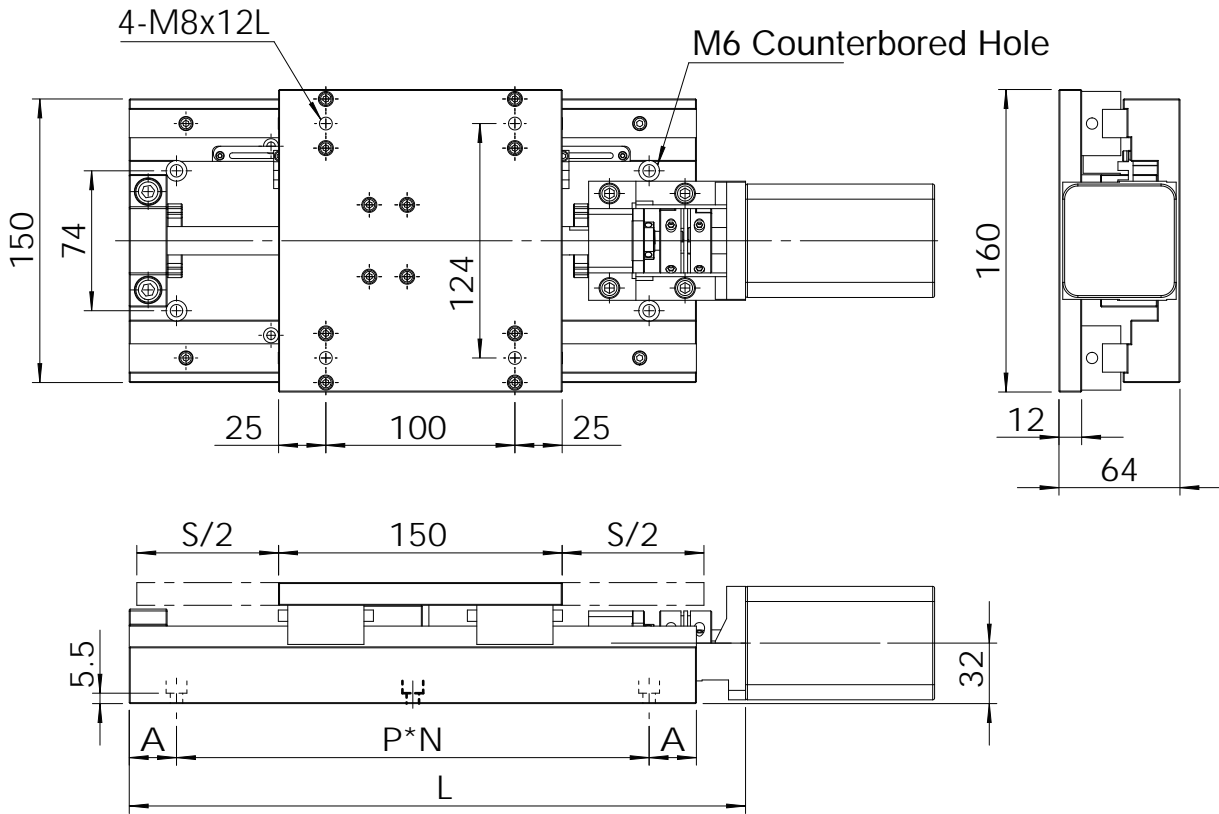

Unit : mm

Model no.		Stroke	Straightness		Mounting Dimensions		Length (L)
Precision Class	Standard Class	S	Precision Class	Standard Class	A	PxN	
SX15-05P	SX15-05R	±25	0.005	0.01	37.5	125x1	226
SX15-10P	SX15-10R	±50	0.005	0.01	62.5	125x1	276
SX15-15P	SX15-15R	±75	0.01	0.015	25	125x2	326
SX15-20P	SX15-20R	±100	0.01	0.02	50	125x2	376
SX15-25P	SX15-25R	±125	0.02	0.025	75	125x2	426
SX15-30P	SX15-30R	±150	0.02	0.03	37.5	125x3	476
SX15-40P	SX15-40R	±200	0.02	0.04	25	125x4	576
SX15-50P	SX15-50R	±250	0.025	0.04	75	125x4	676
SX15-60P	SX15-60R	±300	0.03	0.05	62.5	125x5	776
SX15-70P	SX15-70R	±350	0.03	0.05	50	125x6	876
SX15-80P	SX15-80R	±400	0.03	0.05	37.5	125x7	976

Unit : mm

Repeatability		Load Capacity (kgf)	Linear Guide Way		Ball Screw		Ball Screw Accuracy	
Precision Class	Standard Class		Precision Class	Standard Class	O.D.	Lead	Precision Class	Standard Class
±0.002	±0.006	40	P	H	Ø16 or Ø15	5 or 10	C5	R

SXY15 Two Axis Ball Screw Actuator

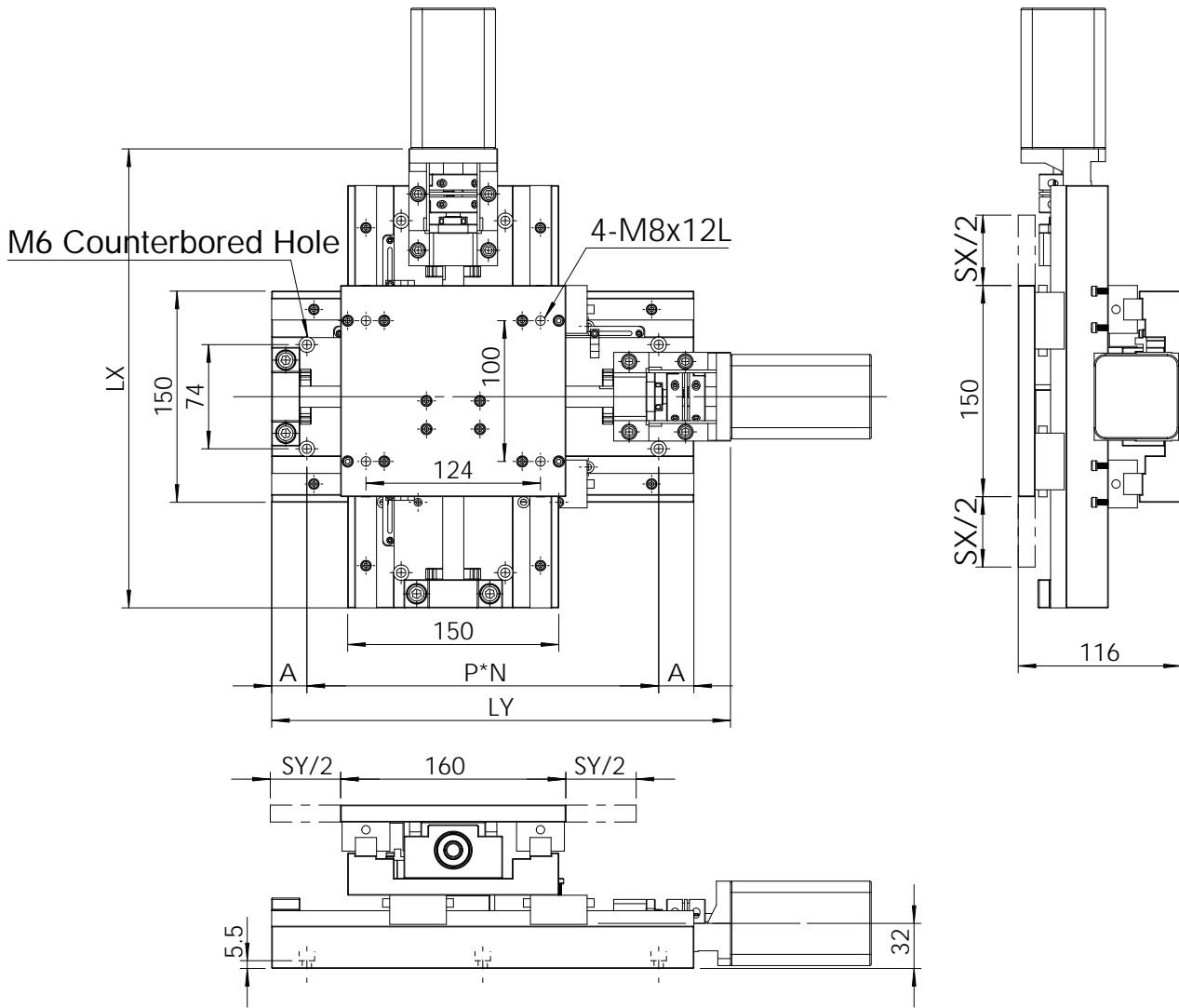

Unit : mm

Model no.		X-axis Stroke	Y-axis Stroke	Straightness		Mounting Dimensions		Length (L)	
Precision Class	Standard Class	SX	SY	Precision Class	Standard Class	A	PxN	LX	LY
SXY15-0505P	SXY15-0505R	± 25	± 25	0.005	0.01	37.5	125x1	226	226
SXY15-0510P	SXY15-0510R	± 25	± 50	0.005	0.01	62.5	125x1	226	276
SXY15-0515P	SXY15-0515R	± 25	± 75	0.01	0.015	25	125x2	226	326
SXY15-1010P	SXY15-1010R	± 50	± 50	0.005	0.01	62.5	125x1	276	276
SXY15-1015P	SXY15-1015R	± 50	± 75	0.01	0.015	25	125x1	276	326
SXY15-1515P	SXY15-1515R	± 75	± 75	0.01	0.015	25	125x2	326	326
SXY15-1520P	SXY15-1520R	± 75	± 100	0.01	0.02	50	125x2	326	376
SXY15-1525P	SXY15-1525R	± 75	± 125	0.02	0.025	75	125x2	326	426
SXY15-1530P	SXY15-1530R	± 75	± 150	0.02	0.03	37.5	125x3	326	476
SXY15-1540P	SXY15-1540R	± 75	± 200	0.02	0.04	25	125x4	326	576
SXY15-1550P	SXY15-1550R	± 75	± 250	0.025	0.04	75	125x4	326	676
SXY15-1560P	SXY15-1560R	± 75	± 300	0.03	0.05	62.5	125x5	326	776
SXY15-1570P	SXY15-1570R	± 75	± 350	0.03	0.05	50	125x6	326	876
SXY15-1580P	SXY15-1580R	± 75	± 400	0.03	0.05	37.5	125x7	326	976

Unit : mm

Repeatability		Load Capacity (kgf)	Linear Guide Way		Ball Screw		Ball Screw Accuracy	
Precision Class	Standard Class		Precision Class	Standard Class	O.D.	Lead	Precision Class	Standard Class
±0.002	±0.006	30	P	H	Ø16 or Ø15	5 or 10	C5	R

Salt Spray Test (72 Hours)



Objective

Detection of nickel-plating surface of support unit the ability of anti-salt spray corrosion.

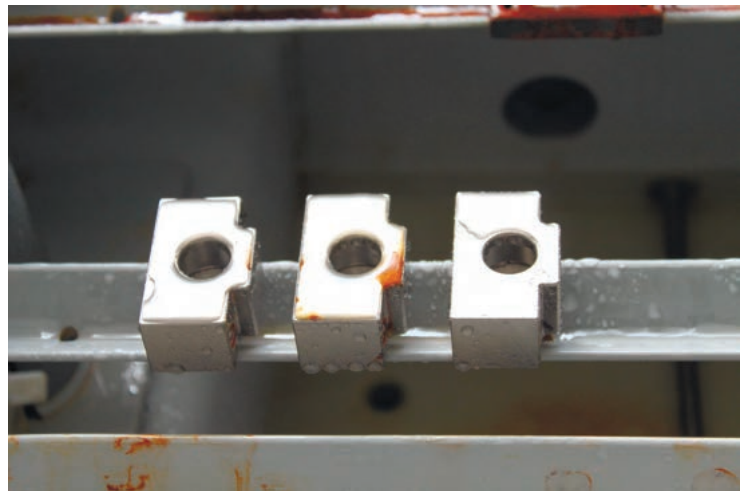

Manual

Salt spray test is a major use of salt spray test equipment created by the artificial analog to assess environmental conditions, salt spray product or metallic materials resistant to corrosion environmental tests.

Artificial analogy environmental test using a certain volume of space, test equipment-salt spray test box. By artificial way to evaluation the product quality and corrosion resistance to salt spray environment.

Exposure in a natural environment, a product sample under test, until their corrosion may take a year, while in the artificial environment, under the conditions of salt spray test analog, as long as 24 hours, you can get similar results.

Patent Product: Support Unit
(Type of Dropping Oil from Center)



Before dropping oil

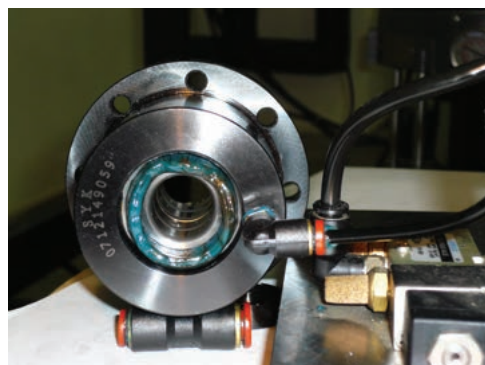

After dropping oil

1. Quick Infiltration

The Support Unit is with the structure of dropping oil from center. Because of the special structure, adding lubricating oil becomes easier. Infiltrate quickly.

2. It's Easy to Changing Old Lubricating Oil

Lubricating oil is easy to be infiltrated to each bearing. Besides that, you can just push the old lubricating oil from the inside part of each bearing, then you can easy to change old lubricating oil periodically.

3. Increasing Lubrication and Decreasing Friction

Because of quick infiltration and easy changing old lubricating oil periodically, it can prevent the increase in frictional temperature and the decrease in friction of bearing. It is very convenient and useful.

Bearings Life Testing



Objective

To get results of bearings life for various brands .

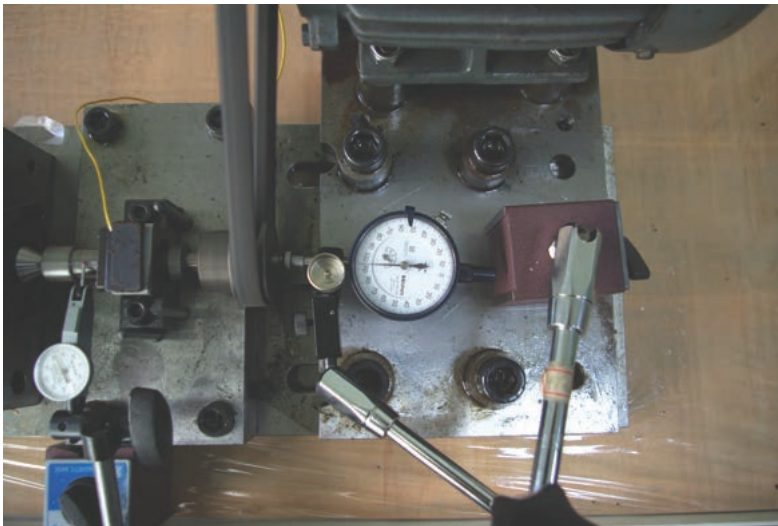

Note

It needs a long time to get the results in normal condition. This test adopted to force maximum axial load on bearings for various brands to get the results in short time , Accordingly, this variation in life is considered statistically ,and calculated life test results.

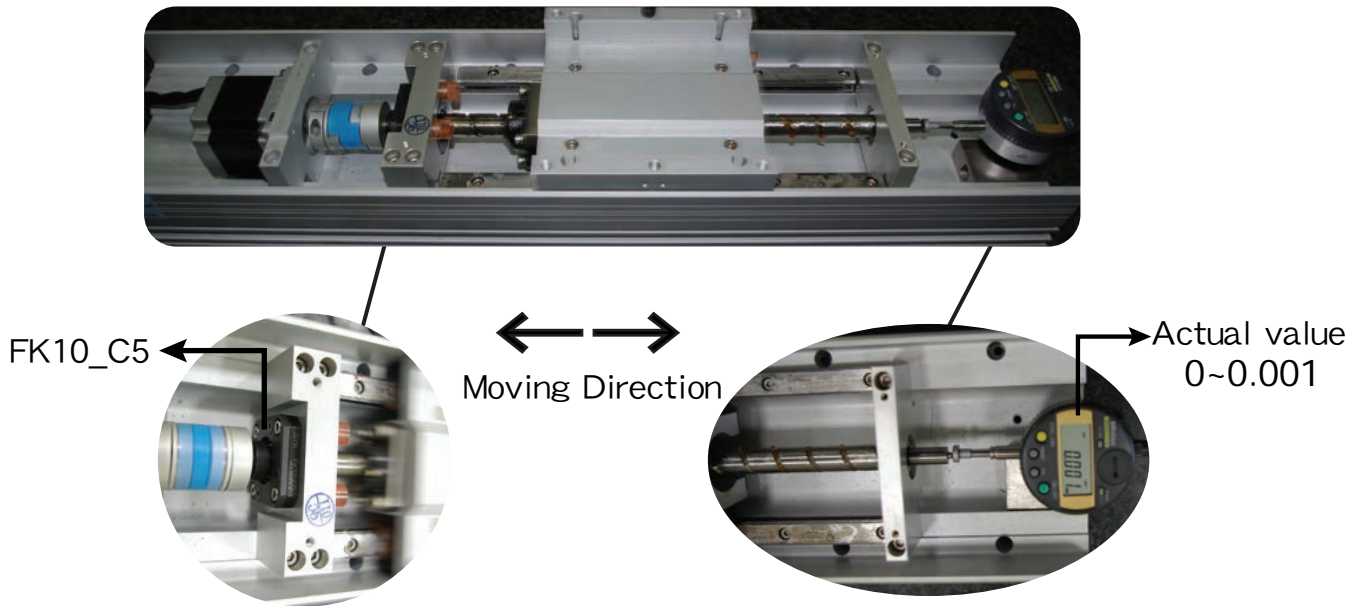

Axial positioning repeatability illustration

Manual

The C5 grade support unit use precision angular contact ball bearings and with axial preload. It is not only can enhance the rigidity for the system, but also can have better positioning repeatability and positioning accuracy for machinery. It is indispensable for high accuracy equipment or machinery.

Thrust Testing

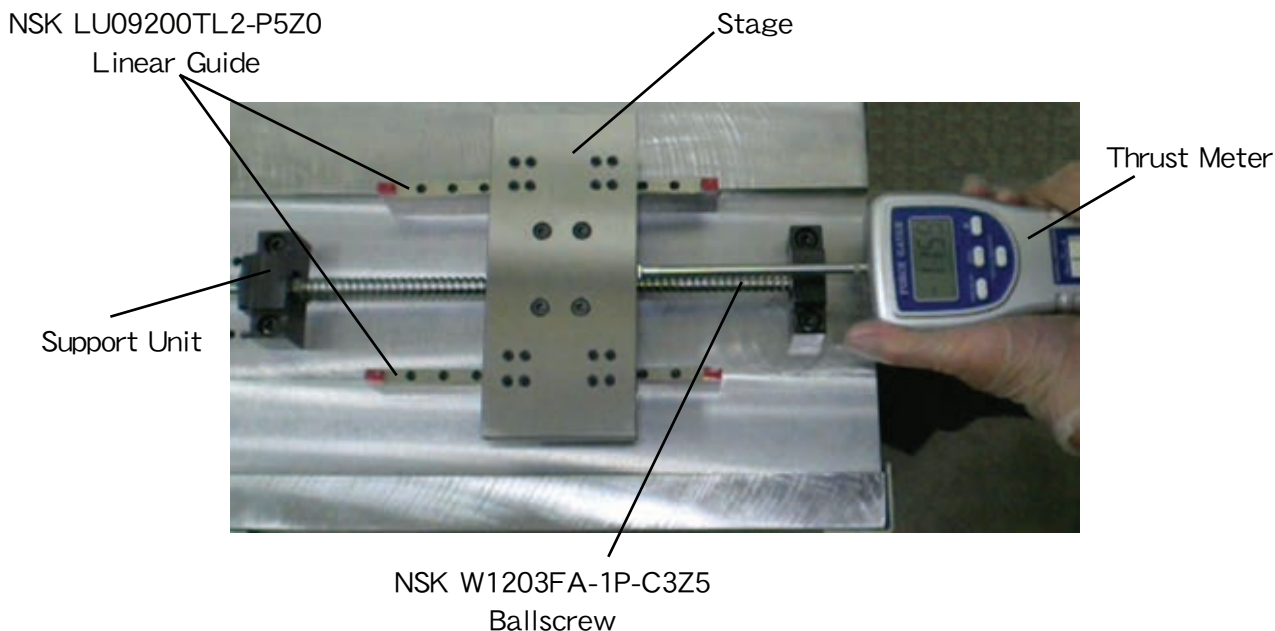

Objective

In order to obtain optimal bearings starting torque, It is very important to control fixed-side support unit in appropriate preload. Under identical motor running condition , It will get optimal starting torque value .. Following are results .

Note

There are axial clearance and weakness rigidity problem for bearings without or insufficient preload.

Too great a preload on bearings can lead to overheating , and increase starting torque of the bearing. Therefore , It lead to reduce out efficiency for motor operation. It also causes increasing bearing temperature and reducing Bearing life.

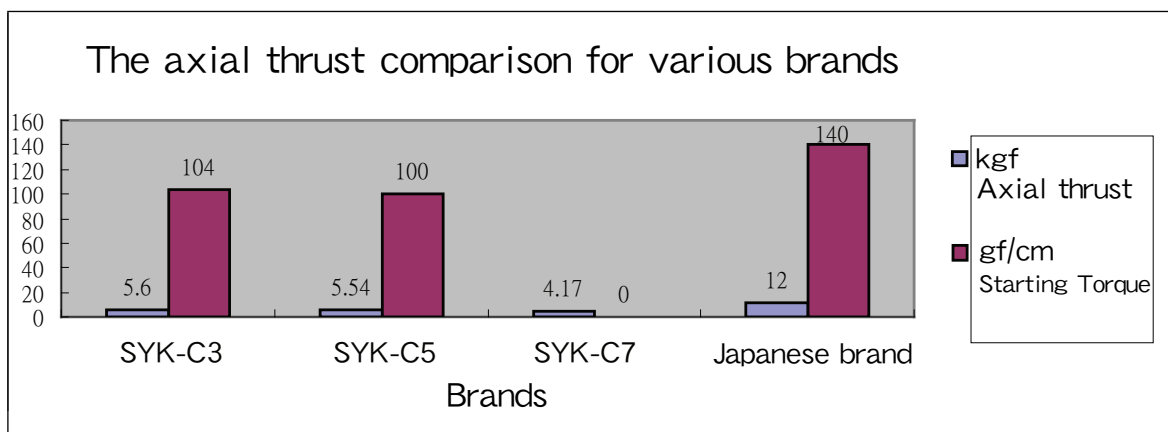



Assembly room

Manufacturing site



Warehouse
Area 800m²





Our measure equipment



ZEISS
CMM, ZEISS, Germany



TRIMOS
2D Measuring machine ,
TRIMOS, Switzerland



Laser carving manufacturing series number on products. It can be traceable quality of products.





SYK follow the Spirit of ISO 9001 Insist On Quality & Keep Improving

Customer First · Ensure Quality



Area 10000^m₂



Area 2200^m₂

Pursue Excellence · Persistent Management

All images and words in the catalogue is for reference only,
the company have the rights to change without prior notice.

Edition# May 2024