

Technology that moves

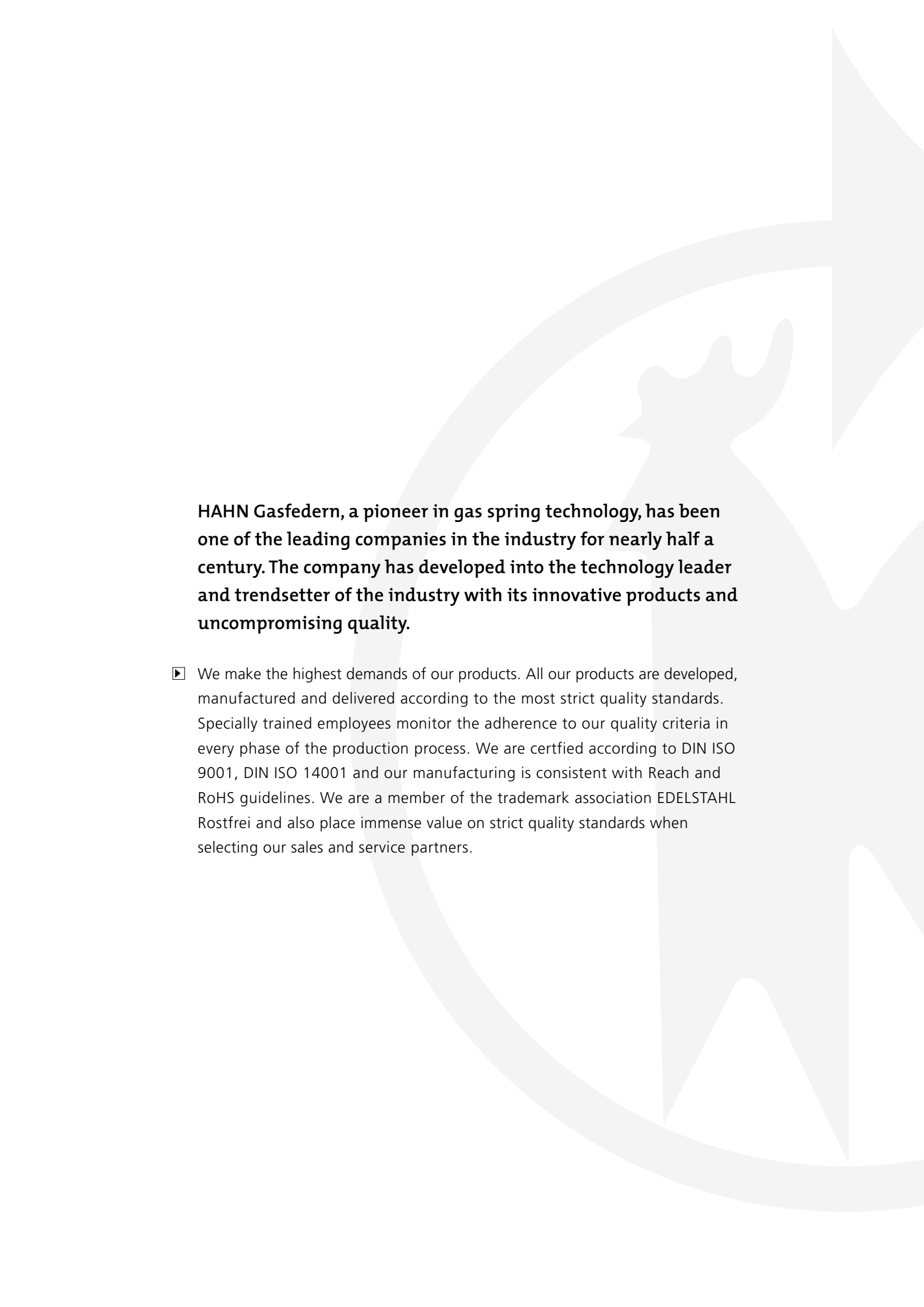

HAHN Gasfedern, a pioneer in gas spring technology, has been one of the leading companies in the industry for nearly half a century. The company has developed into the technology leader and trendsetter of the industry with its innovative products and uncompromising quality.

- ▶ We make the highest demands of our products. All our products are developed, manufactured and delivered according to the most strict quality standards. Specially trained employees monitor the adherence to our quality criteria in every phase of the production process. We are certified according to DIN ISO 9001, DIN ISO 14001 and our manufacturing is consistent with Reach and RoHS guidelines. We are a member of the trademark association EDELSTAHL Rostfrei and also place immense value on strict quality standards when selecting our sales and service partners.

Technology leader in the industry



Partner of industry



No other manufacturer in gas spring technology has such a wide product range as HAHN Gasfedern. The product range includes gas springs, tension springs, locking gas and tension springs, release systems, dampers, special types, brackets and fittings in various different sizes and materials.

- ▶ A wide product range of standard springs can be supplied in next to no time. State-of-the-art production sites allow us to manufacture individual or special designs with short lead times.

In the field of gas springs and oil brakes, the name HAHN Gasfedern stands for highest-level competence in development, quality and consulting as well as short delivery times and adherence to delivery dates.



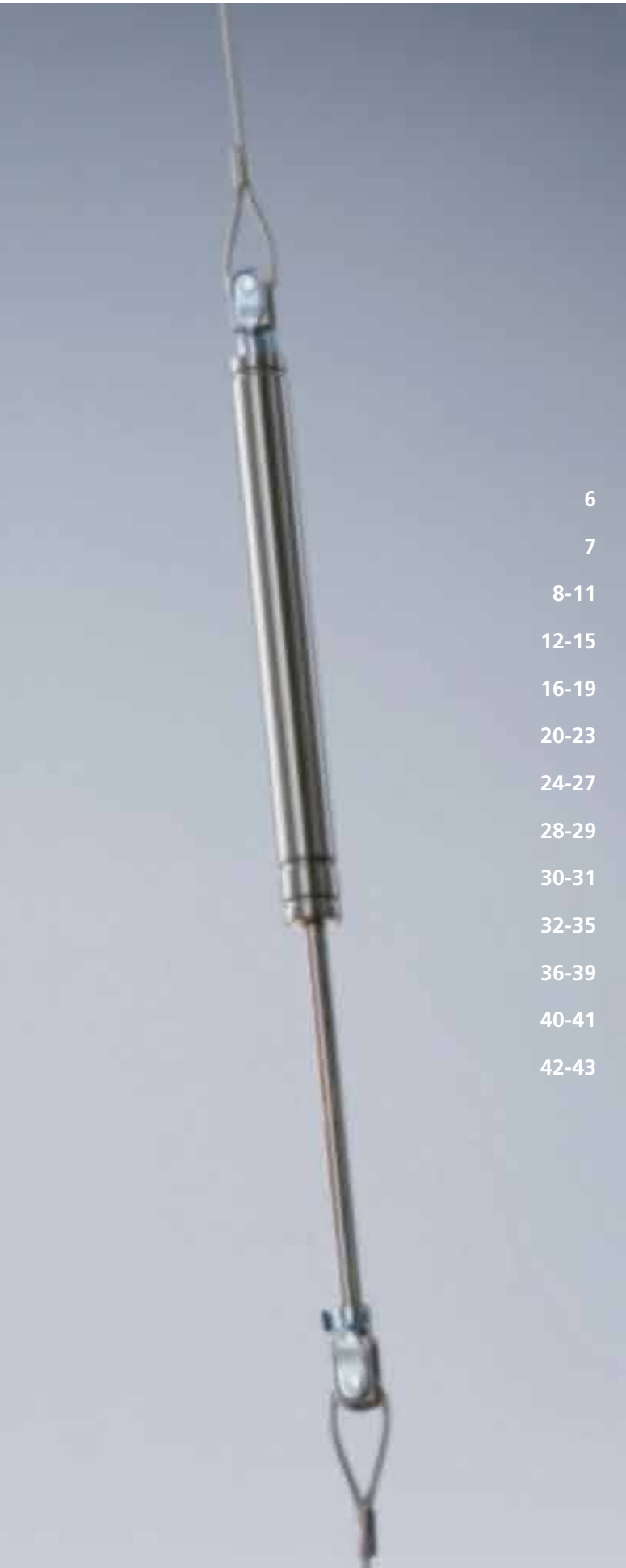

Content

6	Design and function
7	Order system
8-11	Gas springs
12-15	Tension springs
16-19	Locking gas springs
20-23	Release systems
24-27	Oil dampers
28-29	Double-stroke springs
30-31	Telescopic gas springs
32-35	Fittings
36-39	Brackets
40-41	Extras and technical instructions
42-43	Global sales partners

Design and function of HAHN gas springs

HAHN gas springs are used for all applications that require controlled moving and braking of weights without having to apply strong forces.

- ▶ Gas springs by HAHN are used in virtually every field today. In furniture industry, engineering, for sports, leisure and home appliances, in medical engineering and other areas of industrial and private use. For special applications in medical engineering, the chemicals and food industry and ship-building, we manufacture our products in stainless steel. We produce all types and series in AISI 303/304 and AISI 316L/316Ti and are the market leader in this area. Our gas springs and oil brakes in AISI 316L/316Ti are stainless and resistant to chemicals.

This catalogue will provide you with an overview of our broad product range. You can find more detailed information and data sheets on the individual types, series and qualities on the Internet at www.hahn-gasfedern.de. Additional information and notes can be found in the technical instructions on page 41 of this catalogue or in the Internet.

The order system described here will help you compose the product you require. The order code corresponds to our item designation. The employees of HAHN Gasfedern and your local sales partners (see page 42) will be glad to help you find the right products and support you in every way.

One of the special strengths of HAHN Gasfedern is the development of customer-specific solutions. A highly-qualified team, state-of-the-art CAD workplaces and high-quality machinery allow us to find solutions for your application challenges and to realise them with short lead times.

Order system

G | **1** | **4** | **2** | **8** | **0** | **2** | **5** | **0** | **1** | **0** | **6** | **5** | **0** | **A** | **U** | **2** | **7** | **A** | **B** | **1** | **6** | **1** | **5** | **0** | **0** | **N** | **1** | **5** | **6** | **V2**

Step 1:

Selection of the product

- G = Gas spring
- Z = Tension spring
- ZD = Tension spring with damping
- ZX = Locking tension spring
- F = Elastic locking gas spring
- S = Rigid locking gas spring
- X = Absolutely rigid locking gas spring
- SL = Free-moving locking gas spring
- SX = Double rigid locking gas spring
- D = Preset oil damper

Step 2:

Select a series on the basis of the required force, the desired stroke and the maximum installation length.

Step 3:

Enter the desired stroke in mm.

Step 4:

Select the damping (1=with, 0=without damping, 9=special nozzle) or the braking direction (1=extension, 2=compression, 3=in both directions).

Step 5:

Enter the installation length in mm (extended from middle to middle of fitting).

Step 6:

Determine the fitting at the piston rod.

Step 7:

Determine the fitting at the cylinder.

Step 8:

Enter the desired nominal force N.

Step 9:

Selection of the extras

- 1 = Wiper ring
- 2 = Lateral valve
- 3 = Piston rod sealing
- 4 = Grease chamber
- 5 = Valve
- 6 = Protection tube
- 7 = Floating piston (add 70% of the stroke length to the determined installation length)
- 8 = Locking device (add 30 mm to the determined installation length)
- 9 = 0.1 mm release
- B3 = Sealing system
- NT = Low-temperature design
- HT = High-temperature design
- RK = Friction element
- V2 = Design completely in stainless steel AISI 303/304
- V4 = Design completely in stainless steel AISI 316L/316Ti

HAHN Gasfedern provides several decades of experience in gas spring technology. The first HAHN gas springs were already developed and produced in 1966.

- ▶ Today we manufacture 17 different series in steel and stainless steel AISI 303/304 and AISI 316L/316Ti. The HAHN modular system provides more than 5 million variants. At the same time, we are the manufacturers of the smallest gas spring in the world, market leaders in the sector of stainless-steel gas springs and the only manufacturers of special series such as double-stroke and telescopic gas springs.



Design and function of HAHN gas springs



- ▶ HAHN gas springs are hydropneumatic, closed and maintenance-free adjustable elements. The spring force F_1 results from the internal pressure (160 bars without load at the most) in the cylinder, which is generated by the filling medium nitrogen. On the gas spring, this pressure is applied to the cross-section of the piston rod. When no load is applied, the piston rod always is extended.

By pushing in the piston rod, the volume in the cylinder is reduced, and the gas is compressed. Thus the gas spring force increases (progression) depending on the diameter of the piston rod and the volume of the cylinder. HAHN gas springs contain an oil filling for lubrication and end damping.

HAHN gas springs are available in steel, in AISI 303/304 and AISI 316L/316Ti.

Gas springs

State-of-the-art production sites with CNC-controlled machines are the basis for ultimate safety, quality and durability.



Standard product range

Type	Ø Rod	Ø Cylinder	Stroke	Standard length	Extension force	Progression
G 02-06	2 mm	6 mm	5 - 50 mm	2 x stroke + 25	5 - 40 N	20 %
G 03-08	3 mm	8 mm	10 - 80 mm	2 x stroke + 32	5 - 100 N	30 %
G 03-10	3 mm	10 mm	10 - 80 mm	2 x stroke + 32	5 - 100 N	20 %
G 04-12	4 mm	12 mm	30 - 180 mm	2 x stroke + 32	10 - 180 N	25 %
G 06-15	6 mm	15.6 mm	20 - 300 mm	2 x stroke + 55	40 - 400 N	22 %
G 06-19	6 mm	19 mm	20 - 300 mm	2 x stroke + 55	40 - 400 N	17 %
G 08-19	8 mm	19 mm	40 - 500 mm	2 x stroke + 70	50 - 700 N	30 %
G 08-23	8 mm	23 mm	40 - 500 mm	2 x stroke + 70	50 - 700 N	18 %
G 10-23	10 mm	23 mm	40 - 500 mm	2 x stroke + 70	100 - 1200 N	30 %
G 10-28	10 mm	28 mm	40 - 500 mm	2 x stroke + 70	100 - 1200 N	20 %
G 10-40	10 mm	40 mm	30 - 500 mm	2 x stroke + 100	150 - 1200 N	8 %
G 14-28	14 mm	28 mm	50 - 600 mm	2 x stroke + 107	150 - 2500 N	40 %
G 14-40	14 mm	40 mm	50 - 600 mm	2 x stroke + 100	150 - 2500 N	16 %
G 20-40	20 mm	40 mm	50 - 600 mm	2 x stroke + 138	300 - 5000 N	40 %
G 22-40	22 mm	40 mm	50 - 1000 mm	2 x stroke + 138	500 - 6000 N	43 %
G 25-55	25 mm	55 mm	100 - 1000 mm	2 x stroke + 140	500 - 7500 N	40 %
G 30-65	30 mm	65 mm	100 - 1000 mm	2 x stroke + 160	750 - 10000 N	35 %

For additional product details, see Internet: www.hahn-gasfedern.de



Thread rod	Thread cylinder	Extras	Steel	AISI 303/304	AISI 316L/316Ti
M 2	M 2	5	•	-	•
M 3.5	M 3.5	5, 6	•	-	•
M 3.5	M 3.5	5, 6	•	-	•
M 3.5	M 3.5	5, 6, 7	•	-	•
M 5	M 5	4, 5, 6, 7, NT, RK, HT	•	•	•
M 5	M 8	2, 4, 5, 6, 7, NT	•	•	o. r.
M 8	M 8	1, 2, 4, 5, 6, 7, 8, NT, HT	•	•	•
M 8	M 8	2, 4, 5, 6, 7	•	o. r.	o. r.
M 8	M 8	1, 2, 4, 5, 6, 7, 8, B3, NT, HT, RK	•	•	•
M 8	M 8	2, 4, 5, 6, 7, 8, B3, NT, HT	•	•	•
M 8	M 14 x 1.5	2, 4, 5, 6, 7	•	•	•
M 10	M 10	1, 2, 4, 5, 6, 7, 8, NT, HT	•	•	•
M 10	M 10	1, 2, 4, 5, 6, 7, 8, B3	•	•	o. r.
M 14 x 1.5	M 14 x 1.5	1, 2, 4, 6, 7, B3, NT, HT	•	•	•
M 14 x 1.5	M 14 x 1.5	1, 2, 4, 6, 7	•	•	-
M 20 x 1.5	M 20 x 1.5	2, 6	•	-	-
M 24 x 2	M 24 x 2	2, 6	•	-	-

Tension springs



HAHN tension springs are used for all applications where normal gas springs cannot be used for lack of space.

- ▶ Tension springs work in the opposite way as gas springs, i.e. the piston rod is pulled towards the inside by means of the gas pressure in the cylinder. The spring force F_1 results from the internal pressure (160 bars without load at the most) in the cylinder, which is generated by the filling medium nitrogen. In the tension spring, the piston ring area between the piston rod and the inside cylinder diameter is decisive. When no load is applied, the piston rod always is compressed. The tension springs of series 'Z' have no damping. The series ZD is available with damping and series ZX is available as locking tension spring.

HAHN tension springs are available in steel, in AISI 303/304 and AISI 316L/316Ti.

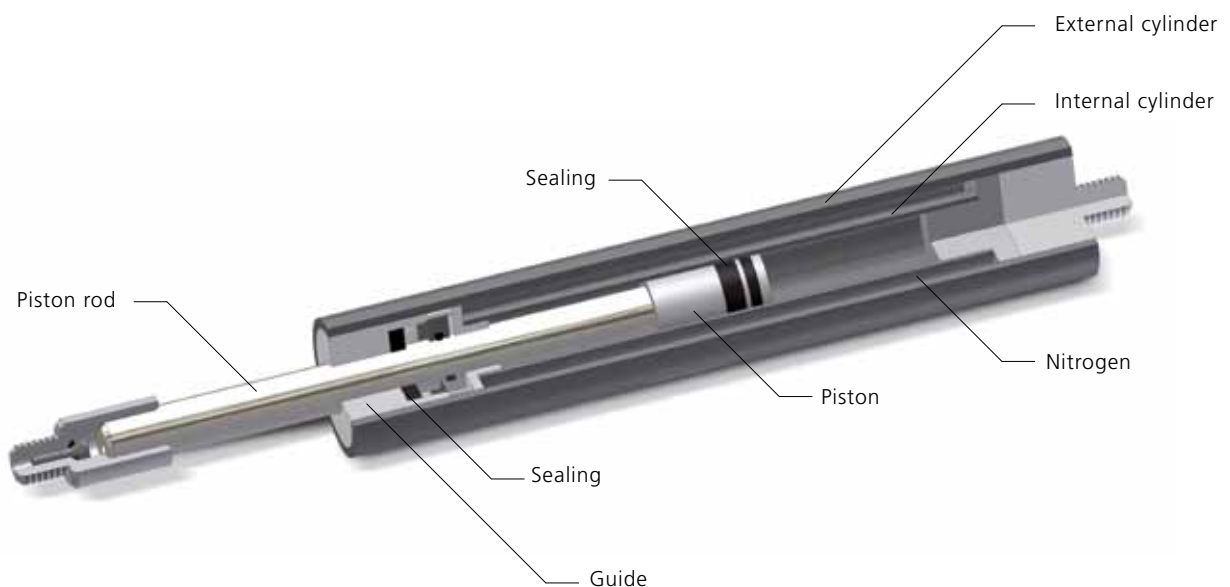

Tension springs

Experienced engineers and technicians support you in implementing your projects and develop optimum solutions.



Standard product range

Type	Ø Rod	Ø Cylinder	Stroke	Standard length	Tension force	Progression
Z 04-15	4 mm	15 mm	20 - 200 mm	2 x stroke + 63	50 - 300 N	22 %
Z 06-19	6 mm	19 mm	30 - 400 mm	2 x stroke + 100	30 - 350 N	10 %
Z 10-28	10 mm	28 mm	60 - 600 mm	2 x stroke + 100	150 - 1200 N	20 %
Z 10-40	10 mm	40 mm	10 - 590 mm	2 x stroke + 150	200 - 2000 N	40 %
Z 28-40	28 mm	40 mm	50 - 700 mm	2.5 x stroke + 125	500 - 5000 N	40 %

Tension spring with damping

Type	Ø Rod	Ø Cylinder	Stroke	Standard length	Tension force	Progression
ZD 10-28	10 mm	28 mm	20 - 600 mm	3 x stroke + 90	100 - 1200 N	36 %

Tension spring with locking

Type	Ø Rod	Ø Cylinder	Stroke	Standard length	Tension force	Progression
ZX 10-28	10 mm	28 mm	30 - 300 mm	2 x stroke + 100	30 - 330 N	10 %

For additional product details, see Internet: www.hahn-gasfedern.de

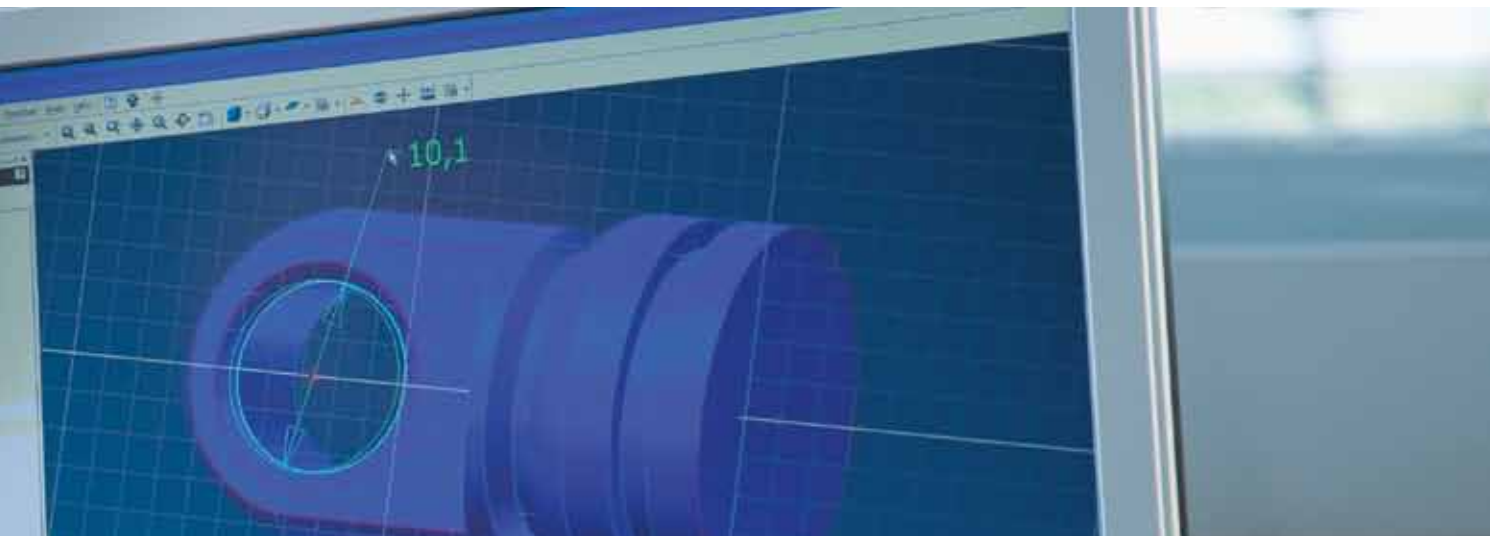

Thread rod	Thread cylinder	Extras	Steel	AISI 303/304	AISI 316L/316 Ti
M 3.5	M 3.5	-	•	-	•
M 5	M 5	4, 6, NT	•	•	•
M 8	M 8	2, 4, 6, NT, HT	•	•	•
M 14 x 1.5	M 14 x 1.5	4, 6	•	•	•
M 14 x 1.5	M 14 x 1.5	2, 6	•	•	•

Thread rod	Thread cylinder	Extras	Steel	AISI 303/304	AISI 316L/316 Ti
M 8	M 8	4, 6	•	o. r.	o. r.

Thread rod	Thread cylinder	Extras	Steel	AISI 303/304	AISI 316L/316 Ti
M 8	M 8	4, 6, B3, NT, HT	o. r.	o. r.	o. r.

Locking gas springs



HAHN locking gas springs can be locked steplessly along the complete stroke. Furniture, vehicle seats, flaps, etc. can be locked in the desired position and readjusted.

- ▶ When the release is actuated, the piston valve opens. In the elastic locking gas springs it is nitrogen, in the rigid locking gas springs it is oil that flows through the piston, and the piston rod is extended or can be pushed in. When the release is actuated, the valve in the gas spring closes automatically, and the piston rod is locked in the desired position. HAHN Gasfedern adjusts the locking type exactly to the individual circumstances. The customers can choose between elastic locking, rigid locking, absolutely rigid locking, free-moving locking and locking in both directions.

HAHN locking gas springs are available in steel, in AISI 303/304 and in AISI 316L/316Ti.

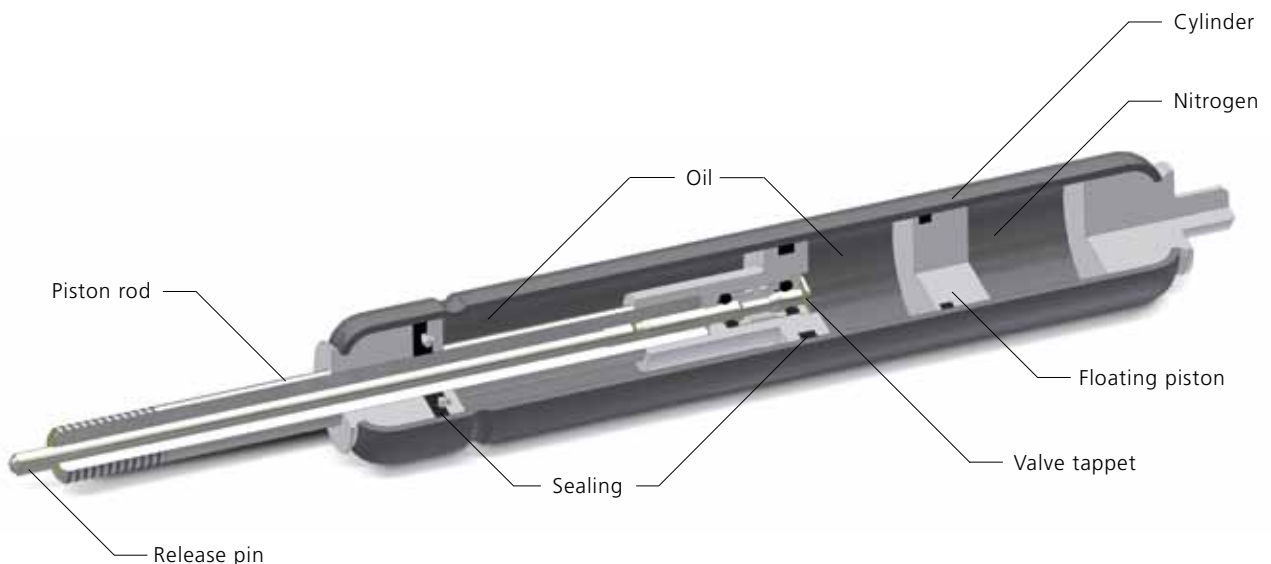

Locking gas springs

Elastic locking gas springs

Type	Ø Rod	Ø Cylinder	Stroke	Standard length	Extension force	Progression
F 06-19	6 mm	19 mm	40 - 150 mm	2.4 x stroke + 70	60 - 400 N	20 %
F 10-23	10 mm	23 mm	20 - 400 mm	2 x stroke + 90	150 - 1200 N	35 %
F 10-28	10 mm	28 mm	20 - 400 mm	2 x stroke + 90	150 - 1200 N	25 %
F 10-40	10 mm	40 mm	20 - 400 mm	2 x stroke + 90	200 - 1200 N	15 %
F 14-40	14 mm	40 mm	20 - 500 mm	2 x stroke + 100	250 - 2500 N	33 %

Rigid locking gas springs

Type	Ø Rod	Ø Cylinder	Stroke	Standard length	Extension force	Progression
S 06-19	6 mm	19 mm	30 - 150 mm	2.4 x stroke + 65	60 - 400 N	35 %
S 10-23	10 mm	23 mm	20 - 400 mm	2.5 x stroke + 90	150 - 1200 N	50 %
S 10-28	10 mm	28 mm	20 - 400 mm	2.4 x stroke + 80	180 - 1200 N	45 %
S 10-40	10 mm	40 mm	20 - 400 mm	2.2 x stroke + 100	250 - 1200 N	33 %
S 14-40	14 mm	40 mm	20 - 500 mm	2.4 x stroke + 95	300 - 2500 N	20 %

Absolut (on compression) rigid locking gas springs

Type	Ø Rod	Ø Cylinder	Stroke	Standard length	Extension force	Progression
X 10-23	10 mm	23 mm	20 - 400 mm	2.6 x stroke + 80	50 - 1000 N	50 %
X 10-28	10 mm	28 mm	20 - 400 mm	2.6 x stroke + 80	250 - 1000 N	45 %
X 10-40	10 mm	40 mm	20 - 400 mm	2.4 x stroke + 84	150 - 1200 N	50 %
X 14-40	14 mm	40 mm	20 - 500 mm	3.7 x stroke + 84	60 - 1200 N	50 %

Free-moving locking gas springs

Type	Ø Rod	Ø Cylinder	Stroke	Standard length	Extension force	Progression
SL 10-28	10 mm	28 mm	20 - 400 mm	2.4 x stroke + 80	80 - 1200 N	25 %

Double locking (on compression + extension) gas springs

Type	Ø Rod	Ø Cylinder	Stroke	Standard length	Extension force	Progression
SX 10-28	10 mm	28 mm	20 - 300 mm	3 x stroke + 86	0 - 1200 N	29 %

For additional product details, see Internet: www.hahn-gasfedern.de

Thread rod	Thread cylinder	Locking force tension	Locking force compression	Release way	Extras	Steel	AISI 303/304	AISI 316L/316Ti
M 6 x 0.75	M 8	-	-	2 - 4 mm	4, 5	•	•	o. r.
M 10 x 1	M 8	-	-	2 - 4 mm	3, 4, 5, 6, 9	•	•	o. r.
M 10 x 1	M 8	-	-	2 - 4 mm	3, 4, 5, 6, 9, B3	•	•	o. r.
M 10 x 1	M 10	-	-	2 - 4 mm	3, 4, 6	•	•	o. r.
M 14 x 1.5	M 14 x 1.5	-	-	2 - 4 mm	1, 2, 4, 6	•	-	-

Thread rod	Thread cylinder	Locking force tension	Locking force compression	Release way	Extras	Steel	AISI 303/304	AISI 316L/316Ti
M 6 x 0.75	M 8	3 x F1	3 x F1	2 - 4 mm	5	•	•	o. r.
M 10 x 1	M 8	max. 3000 N	4 x F1	2 - 4 mm	3, 4, 5, 6, 9	•	•	o. r.
M 10 x 1	M 8	max. 3000 N	5.5 x F1	2 - 4 mm	3, 4, 5, 6, 9	•	•	o. r.
M 10 x 1	M 10	max. 3000 N	12 x F1	2 - 4 mm	3, 4, 6	•	•	o. r.
M 14 x 1.5	M 14 x 1.5	max. 3000 N	6.5 x F1	2 - 4 mm	1, 2, 4, 6	•	-	-

Thread rod	Thread cylinder	Locking force tension	Locking force compression	Release way	Extras	Steel	AISI 303/304	AISI 316L/316Ti
M 10 x 1	M 8	2 x F1	10000 N - 5xF1	2 - 4 mm	3, 6	•	•	o. r.
M 10 x 1	M 8	2 x F1	10000 N - 5xF1	2 - 4 mm	3, 6, 9	•	•	o. r.
M 10 x 1	M 10	12 x F1	10000 N	2 - 4 mm	3, 6	•	•	o. r.
M 14 x 1.5	M 14 x 1.5	5.6 x F1	10000 N	2 - 4 mm	6	•	-	-

Thread rod	Thread cylinder	Locking force tension	Locking force compression	Release way	Extras	Steel	AISI 303/304	AISI 316L/316Ti
M 10 x 1	M 8	max. 3000 N	5.5 x F1	2 - 4 mm	3, 6, 9	•	•	o. r.

Thread rod	Thread cylinder	Locking force tension	Locking force compression	Release way	Extras	Steel	AISI 303/304	AISI 316L/316Ti
M 10 x 1	M 8	10000 N	10000 N	2 - 4 mm	5, 6	•	•	o. r.

Lever releases for locking gas springs

We offer a wide range of lever releases for the direct release and locking of HAHN locking gas springs. Depending of the respective application, the release can be effected towards the spring, away from the spring or variably on both sides and in every direction.

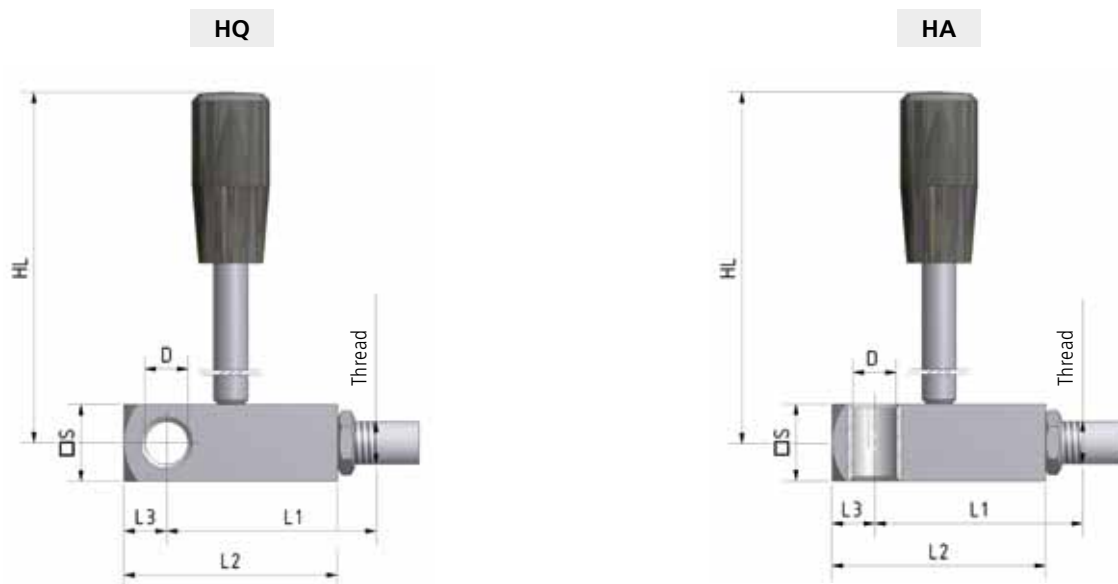

Type	Thread	L1	L2	L3	S	D	HL
HA24	M 6 x 0.75	30 mm	27 mm	6 mm	10 mm	6.1 mm	70 mm*
HA40	M 10 x 1	40 mm	42.5 mm	7.5 mm	15 mm	8.1 mm	120 mm*
HQ40	M 10 x 1	40 mm	42.5 mm	7.5 mm	15 mm	8.1 mm	120 mm*
HA47	M 14 x 1.5	47 mm	50 mm	10 mm	18 mm	10.1 mm	120 mm*
HQ47	M 14 x 1.5	47 mm	50 mm	10 mm	18 mm	10.1 mm	120 mm*

* Other lever lengths on request

Release head	Aluminium anodised
Operating lever	Steel zinc-plated (for HA24, lever is steel/black oxide)
Cylinder button	Plastic (HA24 without cylinder button)



HD

HZ

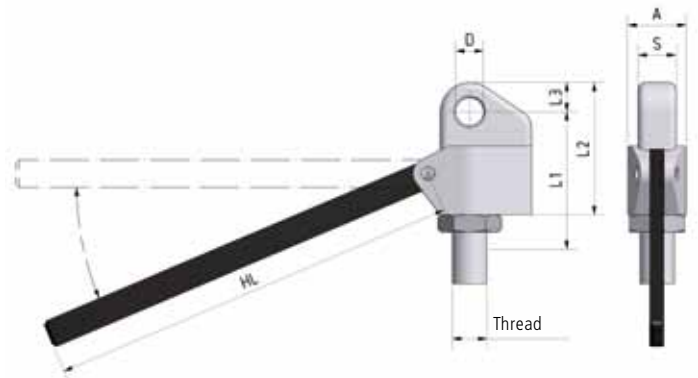
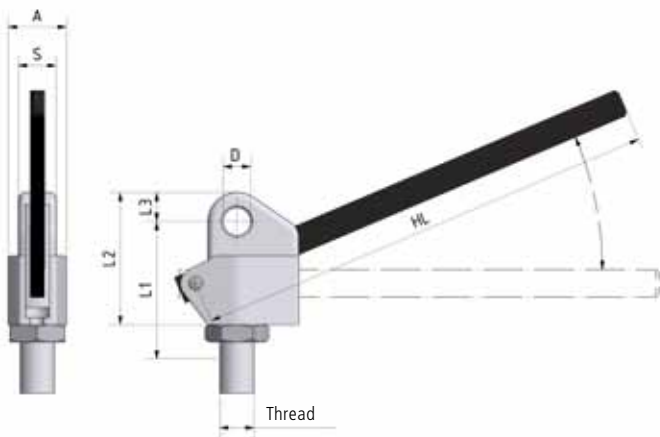

Type	Thread	L1	L2	L3	A	S	D	HL
HD 35-6	M 6 x 0.75	40 mm	38.5 mm	8.5 mm	17 mm	11 mm	8.1 mm	130 mm*
HD 35-10	M 10 x 1	40 mm	38.5 mm	8.5 mm	17 mm	11 mm	8.1 mm	130 mm*
HZ 35-6	M 6 x 0.75	40 mm	38.5 mm	8.5 mm	17 mm	11 mm	8.1 mm	130 mm*
HZ 35-10	M 10 x 1	40 mm	38.5 mm	8.5 mm	17 mm	11 mm	8.1 mm	130 mm*

* Other lever lengths on request

Release head Aluminium die casting
Operating lever Steel/black oxide

Bowden cable releases for locking gas springs

Hahn locking gas springs can also be mechanically released and locked over larger distances by means of Bowden cable releases. They are characterised by optimum force transmission, high durability and absolute operational reliability.

Release head Aluminium anodised
Operating lever Steel zinc-plated
Shoe Steel plate zinc-plated

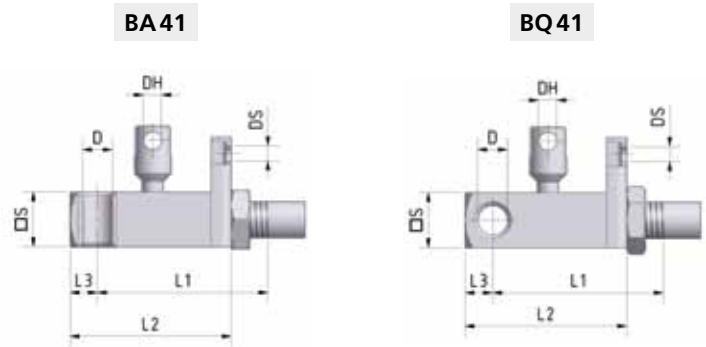

Type	Thread	L1	L2	L3	S	D	DH	DS
BA41	M 10 x 1	41 mm	43.5 mm	7.5 mm	15 mm	8.1 mm	5.1 mm	4.1 mm
BQ41	M 10 x 1	41 mm	43.5 mm	7.5 mm	15 mm	8.1 mm	5.1 mm	4.1 mm

Release head Aluminium die casting
Operating lever Plastic

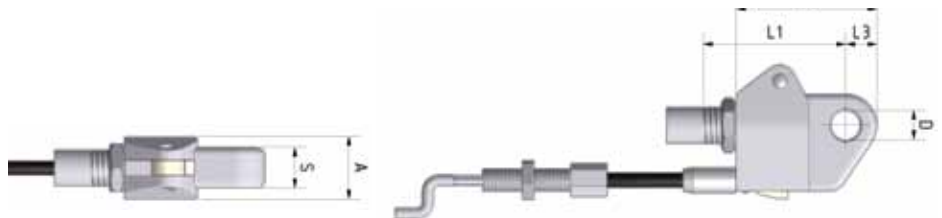

Type	Thread	L1	L2	L3	A	D	S
BD35-10	M 10 x 1	40 mm	38.5 mm	8.5 mm	17 mm	8.1 mm	11 mm

Additional part: Adapter for M6 thread can be ordered

Bowden cables with Z hooks matching the Bowden cable release BD35 in the standard lengths: 500, 750, 1000, 1250 and 1500 mm.

Hydraulic release system HY for locking gas springs

HY 1 · 1 Release for 1 spring

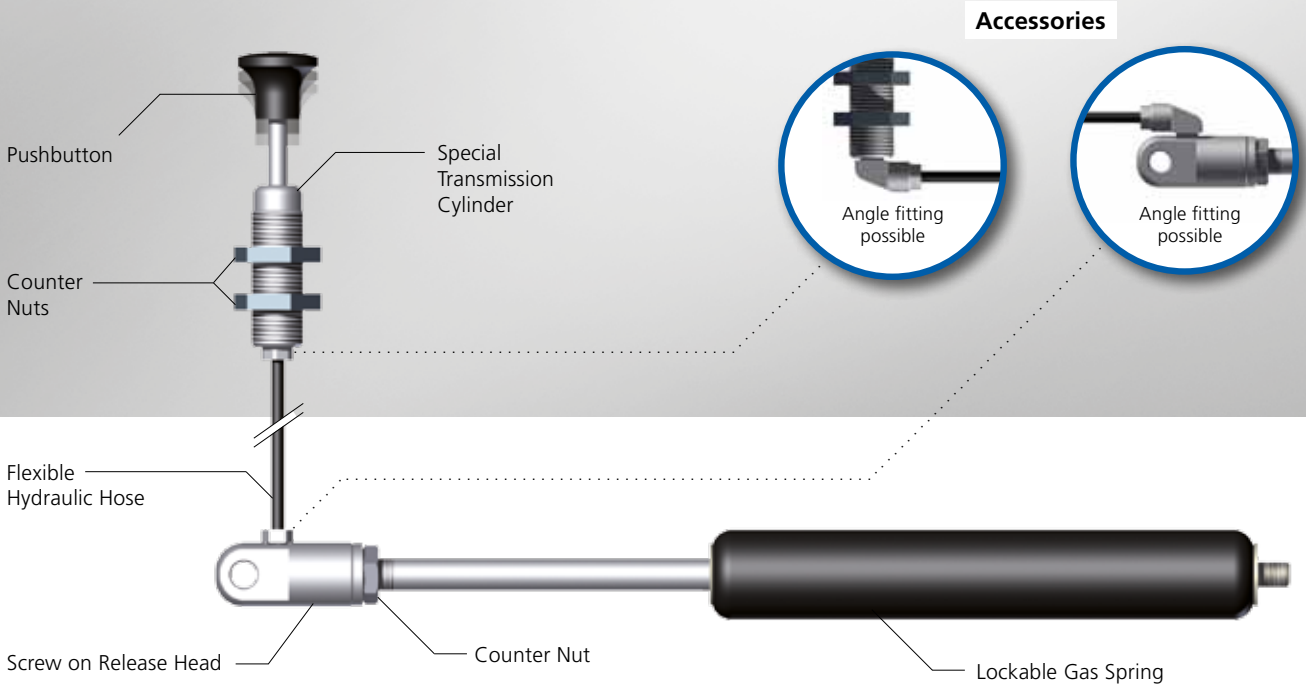

The HAHN Hydraulic Release System is especially made and adapted for your applications and requests.

You are getting a ready-to-install and maintenance-free system with a lot of advantages. Until now, the design and function of your latest designs and developments has been limited by cable controls and lever releases. The HY Release System gives more flexibility, just from the touch of a pushbutton.

Application Range:

- Furniture
- Massage Couches
- Hospital Beds
- Operation Panels
- Table Adjustments
- Safety Systems
- Handling Systems
- Medicine Devices
- Quick Adjustment of Seats for Heavy Plant Machinery, Cranes, Tractors etc.

HY 2 · 1 Release for 2 springs



HY 3 · 2 Releases for 1 spring



HY 4 · 2 Releases for 2 springs



Oil dampers



HAHN oil dampers are used for slowing down moving weights.

- ▶ Oil dampers are closed, maintenance-free hydraulic elements which are used for the smooth slowing of feed units, linear drive units, flaps, etc.

Fixed dampers work in extension, compression or in both directions and can hold up from 5N to 2500N. All fixed dampers are available in different sizes in steel and stainless steel AISI 303/304 and AISI 316L/316Ti.

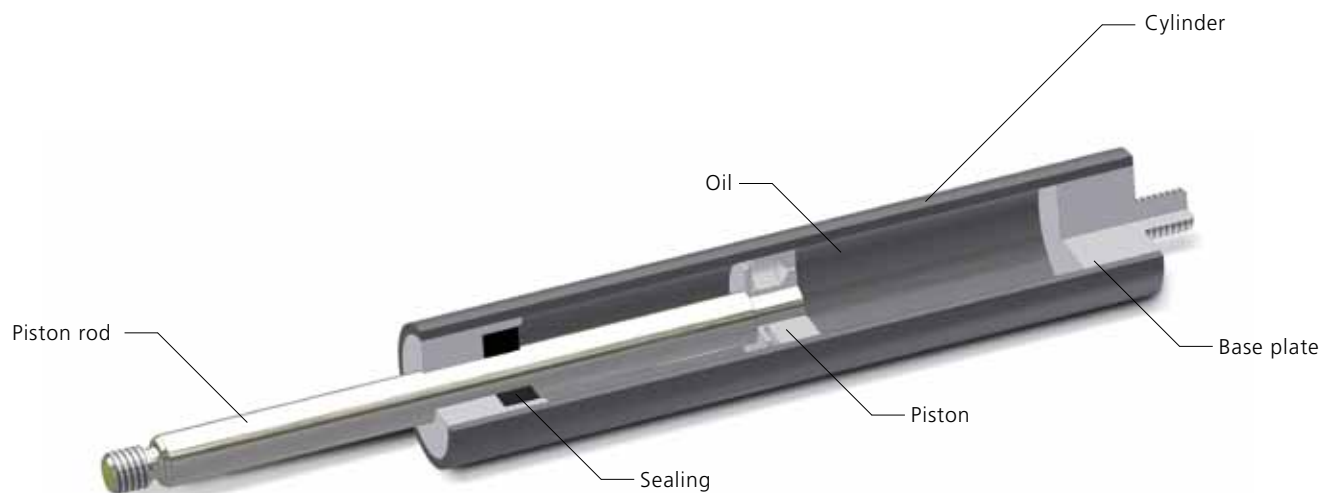

Oil dampers

The advantage of HAHN oil dampers is that the damping force as well as the compression and extension speed can be adjusted according to your requirements.



Standard product range

Type	Ø Rod	Ø Cylinder	Stroke	Standard length	Damping force	Damping
D 04-12	4 mm	12 mm	10 - 200 mm	2 x stroke + 32	5 - 100 N	comp./ext./both-way
D 06-19	6 mm	19 mm	20 - 300 mm	2 x stroke + 35	40 - 400 N	comp./ext./both-way
D 08-23	8 mm	23 mm	40 - 500 mm	2 x stroke + 40	50 - 800 N	comp./ext./both-way
D 10-28	10 mm	28 mm	40 - 500 mm	2 x stroke + 45	120 - 1200 N	comp./ext./both-way
D 14-40	14 mm	40 mm	50 - 600 mm	2 x stroke + 60	400 - 2500 N	comp./ext./both-way



Thread rod	Thread cylinder	Extras	Steel	AISI 303/304	AISI 316L/316Ti
M 3.5	M 3.5	-	•	-	o. r.
M 5	M 5	6, 7	•	•	•
M 8	M 8	6, 7	•	•	o. r.
M 8	M 8	6, 7	•	•	o. r.
M 10	M 10	1, 6, 7	•	•	•

Double-stroke spring

The special strength of HAHN Gasfedern is the solution of customer-specific tasks, for which we also develop unusual springs and products. The patent-protected double-stroke spring is an example for this.

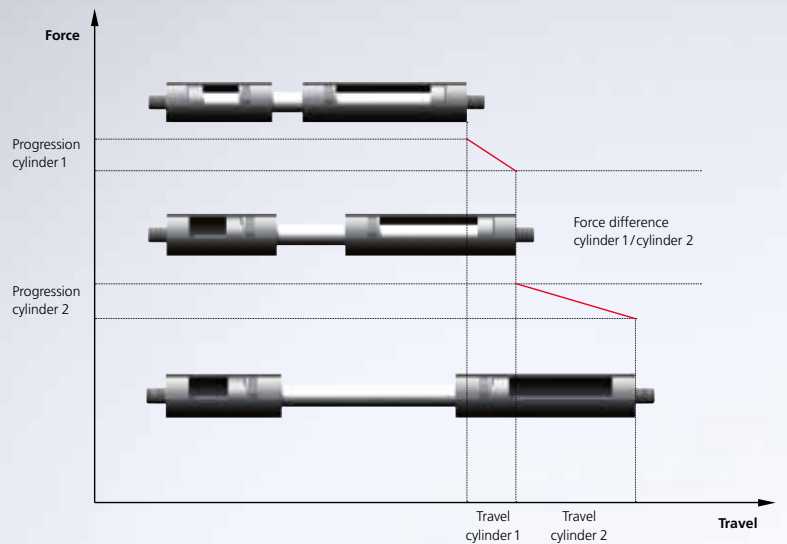

- ▶ HAHN Gasfedern developed special double-stroke springs for heavy flaps with a large opening angle, which are characterised by a low starting and a high ultimate force. These springs have two pressure cylinders that can be filled differently and thus are able to cover two force ranges. The compression of the piston rod generates a bent characteristic curve, which can be better adjusted to the force progression of the flap.

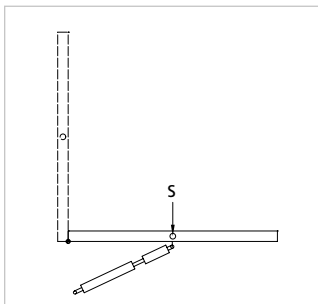

In this position, the point of gravity S is furthest away from the pivot point. The strongest force is required for opening the flap. Both strokes are compressed. The cylinder with the stronger force opens it.

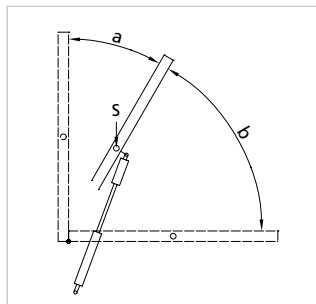

In this position, the point of gravity S moves closer to the pivot point. A weaker spring force is required. Stroke 1 is extended in this position. The spring part 2 with the weaker force now becomes effective.

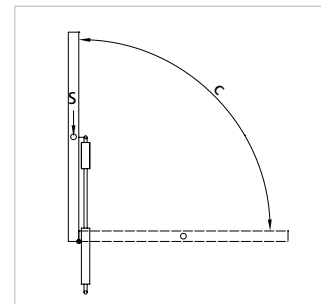

In this position, the point of gravity S is close to or directly on the pivot point. A weak spring force is required. Both strokes are fully extended.

Double-stroke springs are specially designed for the application you require. The force ranges are exactly attuned to each other and adapted to the required kinematics. HAHN double-stroke springs are available in steel, in AISI 303/304 and AISI 316L/316Ti.

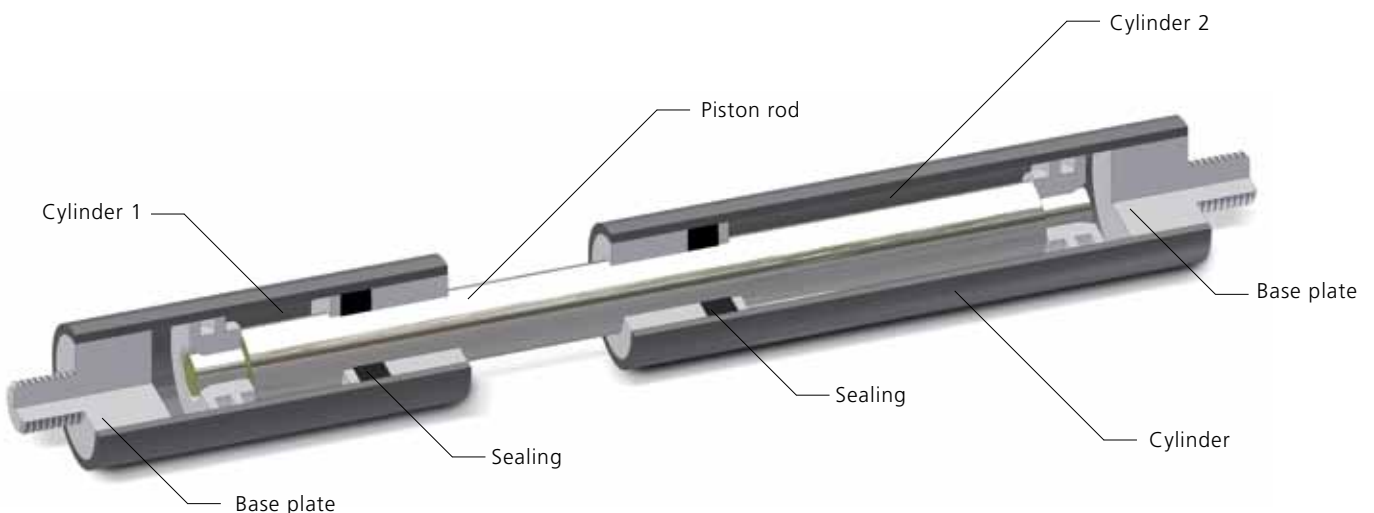

Telescopic gas springs



For applications for which a large stroke is required but only little installation space is available, HAHN telescopic gas springs are the optimum solution.

- ▶ As one of the first manufacturers worldwide, HAHN Gasfedern made the telescope principle in the construction and manufacturing of gas springs marketable. The patent-protected telescopic gas springs consist of several cylinders that are built into each other. As a standard from our modular system, we manufacture the series T-06-15-40 and T-10-28-65. Please send us the data from your application and we will calculate the suitable telescopic gas spring.

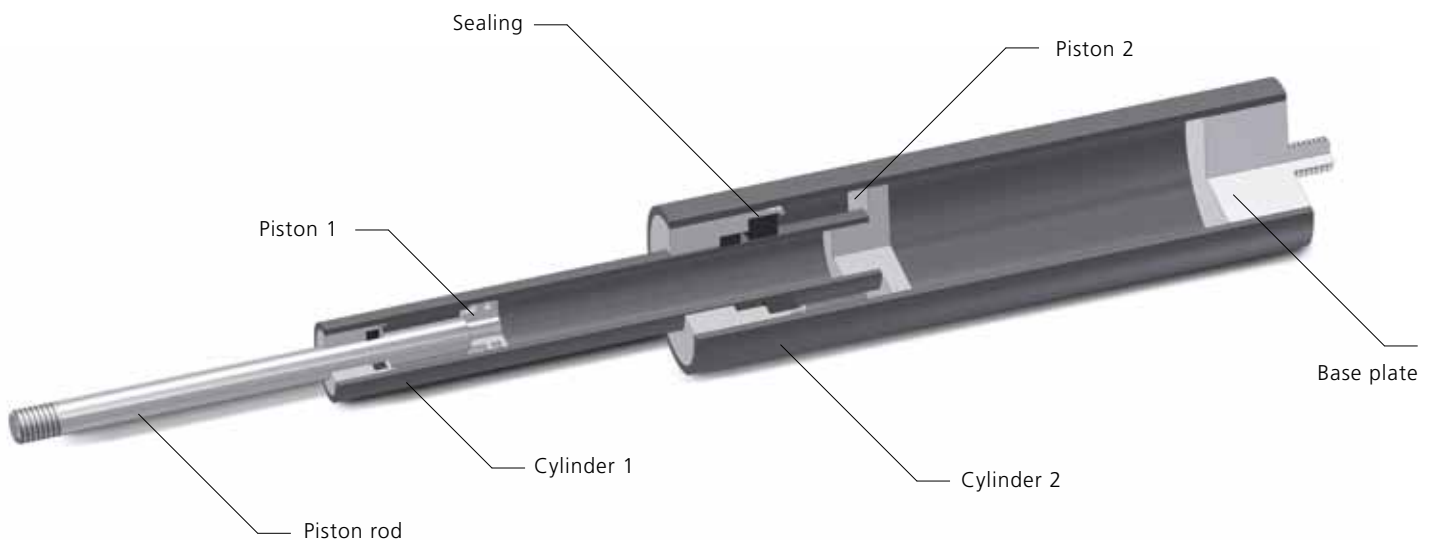

Fittings

With a broad range of fittings, brackets and special accessories, the application options for HAHN gas springs can be combined and extended in every possible way:

- ▣ Various fittings such as fork heads, hinged eyelets, hinged joints etc. are suitable for all mounting applications in combination with the matching brackets for the product. Depending on the individual case, HAHN supplies a variety of different fittings so that customers can select the respectively best solutions from this intelligent modular system.



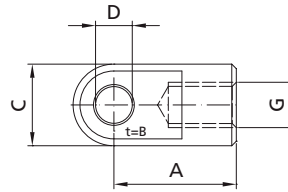

Eyelets

Type	Thread (G)	Installation length (A)	Thickness (B)	Width (C)	Cross hole Ø (D)	Steel	AISI 303 / 304	AISI 316L / 316Ti	Plastic
AU08	M 2	8 mm	3 mm	4 mm	2.1 mm	•	-	-	-
AU11	M 3.5	11 mm	4 mm	8 mm	4.1 mm	•	-	-	-
AS20	M 5	20 mm	3 mm	12 mm	6.1 mm	•	•	-	-
AU16	M 5	16 mm	6 mm	10 mm	6.1 mm	•	•	•	-
AR16	M 5	16 mm	10 mm	12 mm	8.1 mm	•	-	-	-
AK17	M 8	17 mm	14 mm	14 mm	8.1 mm	-	-	-	•
AK21	M 8	21 mm	18 mm	18 mm	8.1 mm	-	-	-	•
AR16	M 8	16 mm	10 mm	15 mm	8.1 mm	•	-	-	-
AR19	M 8	19 mm	10 mm	15 mm	8.1 mm	•	-	-	-
AR19	M 8	19 mm	10 mm	15 mm	10.1 mm	•	-	-	-
AR27	M 8	27 mm	10 mm	15 mm	8.1 mm	•	-	-	-
AS19	M 8	19 mm	8 mm	14 mm	8.1 mm	•	-	-	-
AS24	M 8	24 mm	6 mm	14 mm	8.1 mm	•	-	-	-
AS30	M 8	30 mm	5 mm	18 mm	8.1 mm	•	-	-	-
AU19	M 8	19 mm	10 mm	14 mm	8.1 mm	•	•	•	-
AU19	M 8	19 mm	10 mm	14 mm	6.1 mm	•	-	-	-
AK21	M 10	21 mm	18 mm	18 mm	8.1 mm	-	-	-	•
AS27	M 10	27 mm	14 mm	18 mm	8.1 mm	•	-	-	-
AU27	M 10	27 mm	10 mm	18 mm	8.1 mm	•	•	•	-
AU27	M 10	27 mm	10 mm	18 mm	10.1 mm	•	•	•	-
AU42	M 14 x 1.5	42 mm	14 mm	25 mm	14.1 mm	•	•	•	-

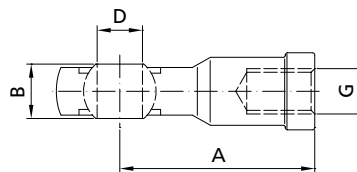

Hinged joints

Type	Thread (G)	Installation length (A)	Thickness (B)	Width	Cross hole Ø (D)	Steel	AISI 303 / 304	AISI 316L / 316Ti	Plastic
AG12	M 2	12.5 mm	4 mm	-	2 mm	-	-	-	•
AG27	M 5	27 mm	8 mm	9 mm	5 mm	•	•	o. r.	-
AG36	M 8	36 mm	12 mm	13 mm	8 mm	•	•	o. r.	-
AG43	M 10	43 mm	14 mm	17 mm	10 mm	•	•	o. r.	-
AG57	M 14 x 1.5	57 mm	19 mm	22 mm	14 mm	•	•	o. r.	-

Fittings

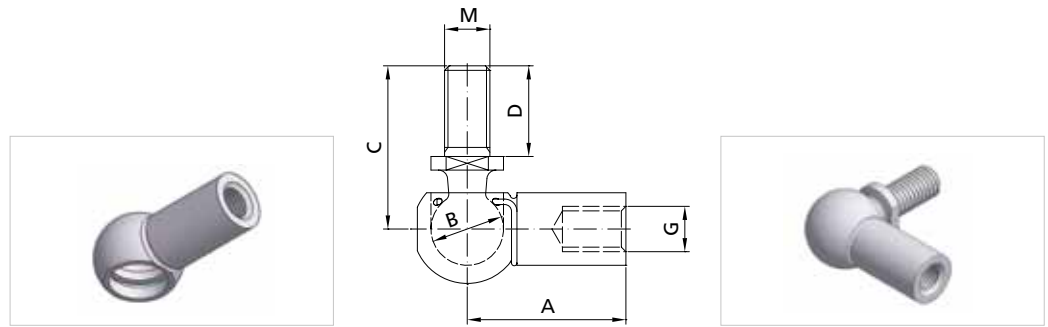

Ball joints and sockets

Type	Thread (G)	Installation length (A)	Socket diameter (B)	Bolt length (C)	Thread (MxD)	Steel	AISI 303/304	AISI 316L/316Ti
PF 12	M 2	12.5 mm	4 mm	12.5 mm	-	•	-	-
WG 12	M 2	12.5 mm	4 mm	12.5 mm	M 2 x 7.5	•	-	-
PX 18	M 3.5	18 mm	8 mm	-	-	•	-	-
WX 18	M 3.5	18 mm	8 mm	19 mm	M 4 x 10	•	-	-
PF 22	M 5	22 mm	8 mm	-	-	•	o. r.	o. r.
PX 22	M 5	22 mm	10 mm	-	-	•	-	-
WD 22	M 5	22 mm	8 mm	19 mm	M 8 x 12	•	-	-
WG 22	M 5	22 mm	8 mm	19 mm	M 5 x 10	•	•	•
WX 22	M 5	22 mm	10 mm	23 mm	M 8 x 12	•	•	-
WY 22	M 5	22 mm	10 mm	23 mm	M 6 x 12	•	-	-
PF 18	M 8	18 mm	10 mm	-	-	•	-	-
PF 30	M 8	30 mm	13 mm	-	-	•	o. r.	o. r.
WD 30	M 8	30 mm	13 mm	29 mm	M 8 x 16	•	-	-
WG 18	M 8	18 mm	10 mm	23 mm	M 8 x 12	•	•	-
WG 30	M 8	30 mm	13 mm	29 mm	M 8 x 16	•	•	•
WS 35	M 8	35 mm	16 mm	36 mm	M 10 x 20	•	-	-
WX 30	M 8	30 mm	13 mm	29 mm	M 10 x 16	•	-	-
PF 35	M 10	35 mm	16 mm	-	-	•	-	-
WG 35	M 10	35 mm	16 mm	36 mm	M 10 x 20	•	•	•
WG 45	M 14 x 1.5	45 mm	19 mm	48 mm	M 14 x 28	•	•	•

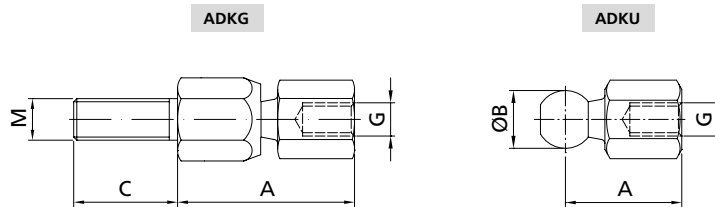

Axial joints



Type	Thread (G)	Installation length (A)	Ball diameter (B)	Bolt (MxC)	Steel	AISI 303/304	AISI 316L/316Ti
ADKG	M 5	28 mm	8 mm	M 8 x 35	•	-	-
ADKU	M 5	20 mm	8 mm	-	•	-	-
ADKG	M8	31 mm	10 mm	M 8 x 35	•	-	o. r.
ADKU	M 8	23 mm	10 mm	-	•	-	-
ADKG	M10	43 mm	14 mm	M 10 x 25	•	-	o. r.
ADKU	M 10	28 mm	14 mm	-	•	-	-
ADKG	M 14 x 1.5	56 mm	20 mm	M 14 x 1.5 x 40	•	-	-
ADKU	M 14 x 1.5	35 mm	20 mm	-	•	-	-

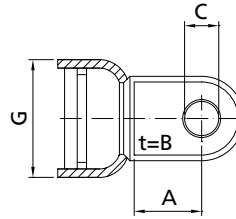

Base plate eyelet

Type	For cylinder Ø (G)	Installation length (A)	Thickness (B)	Cross hole Ø (C)	Steel	AISI 303/304	AISI 316L/316Ti
AB04	6 mm	4 mm	2.5 mm	2.1 mm	•	-	-
AB07	10 mm	7 mm	4 mm	4.1 mm	•	-	-
AB07	12 mm	7 mm	4 mm	4.1 mm	•	-	-
AB09	15 mm	9 mm	6 mm	6.1 mm	•	-	-
AB11	19 mm	11 mm	10 mm	6.1 mm	•	-	-
AB11	19 mm	11 mm	10 mm	8.1 mm	•	-	-
AB11	23 mm	11 mm	10 mm	8.1 mm	•	-	-
AB11	23 mm	11 mm	10 mm	10.1 mm	•	-	-
AB16	28 mm	16 mm	10 mm	8.1 mm	•	-	-
AB16	28 mm	16 mm	10 mm	10.1 mm	•	-	-
AZ20	40 mm	20 mm	14 mm	14.1 mm	•	•	-

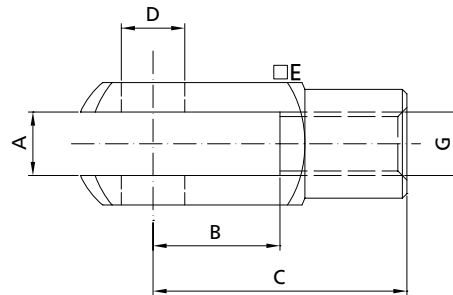

Forks

Type	Thread (G)	Size (A x B)	Installation length (C)	Width (E)	Bolt Ø (D)	Steel	AISI 303/304	AISI 316L/316Ti
GA16	M 3.5	4 x 8 mm	16 mm	8 mm	4 mm	•	-	-
GG16*	M 3.5	4 x 8 mm	16 mm	8 mm	4 mm	•	-	-
GA20	M 5	5 x 10 mm	20 mm	10 mm	5 mm	•	•	-
GG20*	M 5	5 x 10 mm	20 mm	10 mm	5 mm	•	•	•
GA32	M 8	8 x 16 mm	32 mm	16 mm	8 mm	•	•	-
GG32*	M 8	8 x 16 mm	32 mm	16 mm	8 mm	•	•	•
GS40	M 8	10 x 20 mm	40 mm	20 mm	10 mm	•	-	-
GA40	M 10	10 x 20 mm	40 mm	20 mm	10 mm	•	•	-
GG40*	M 10	10 x 20 mm	40 mm	20 mm	10 mm	•	•	•
GS32	M 10	8 x 16 mm	32 mm	16 mm	8 mm	•	-	-
GX32	M 10 x 1	8 x 16 mm	32 mm	16 mm	8 mm	•	-	-
GA56	M 14 x 1.5	14 x 28 mm	56 mm	27 mm	14 mm	•	•	-
GG56*	M 14 x 1.5	14 x 28 mm	56 mm	27 mm	14 mm	•	•	•
GA80	M 20	20 x 40 mm	80 mm	40 mm	20 mm	•	-	-
GA99	M 24	25 x 50 mm	99 mm	50 mm	25 mm	•	-	-

* Fork joint steel with ES-bolts, AISI 303/304 with Ben bolts, AISI 316L/316Ti with eyebolts.

Brackets

Depending on the size and material of your product, the fitting possibilities can also vary. HAHN Gasfedern therefore offers a wide range of matching brackets.



Brackets

BC01

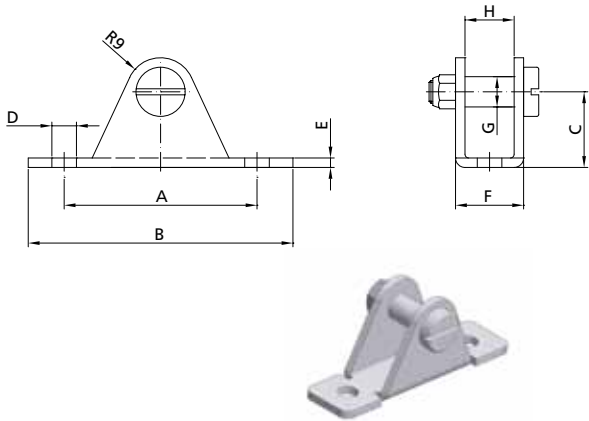

BC04

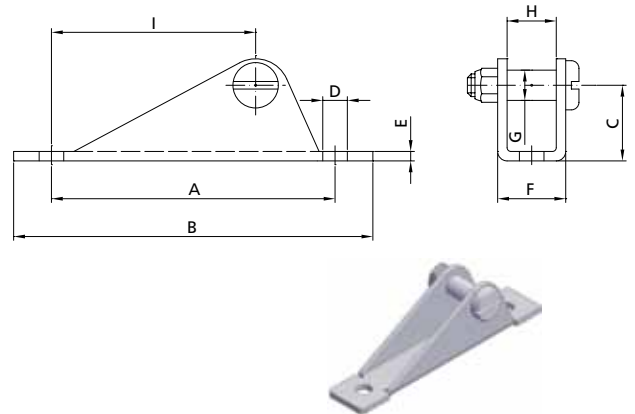

Bearing shoe

Type	A	B	C	D	E	F	G	H	I	Stability	Steel	AISI 316L/Ti
BC01	51 mm	70 mm	20 mm	6.5 mm	2.5 mm	18 mm	8 mm	13 mm	-	1800 N	•	•
BC04	75 mm	95 mm	20 mm	6.5 mm	2.5 mm	18 mm	8 mm	13 mm	54 mm	1800 N	•	•

BA20/K

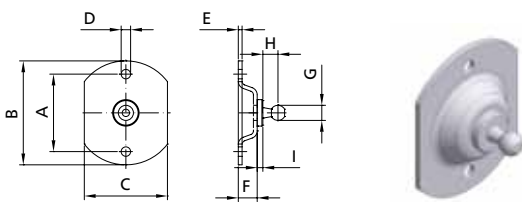

BA20/Z

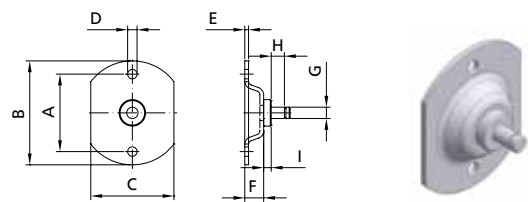

Round bracket

Type	A	B	C	D	E	F	G	H	I	Stability	Steel	AISI 316L/Ti
BA20/K08	41 mm	55 mm	44 mm	5.3 mm	2 mm	10 mm	8 mm	8 mm	3 mm	500 N	•	•
BA20/K10	41 mm	55 mm	44 mm	5.3 mm	2 mm	10 mm	10 mm	9 mm	3 mm	800 N	•	•
BA20/K13	41 mm	55 mm	44 mm	5.3 mm	2 mm	10 mm	13 mm	9.5 mm	3 mm	1200 N	•	•
BA20/Z06	41 mm	55 mm	44 mm	5.3 mm	2 mm	10 mm	6 mm	7 mm	4 mm	500 N	•	•
BA20/Z08	41 mm	55 mm	44 mm	5.3 mm	2 mm	10 mm	8 mm	11 mm	5 mm	1200 N	•	•

Brackets

For optimum use and perfect force transmission, HAHN Gasfedern offers a wide range of fittings and brackets. The displayed examples only are a small excerpt from our product range. If required, we can also develop a tailor-made solution for you.



BA01/K

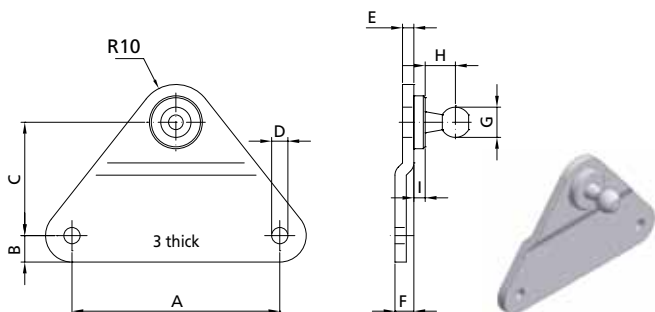

BA01/Z

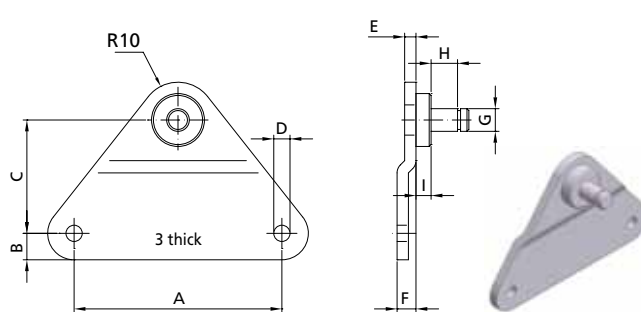

BB01/K

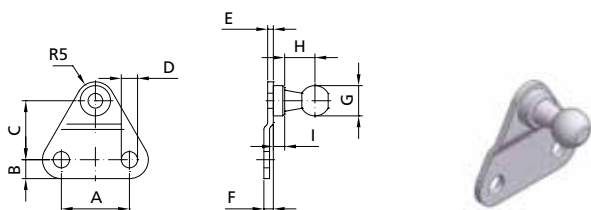

BB01/Z

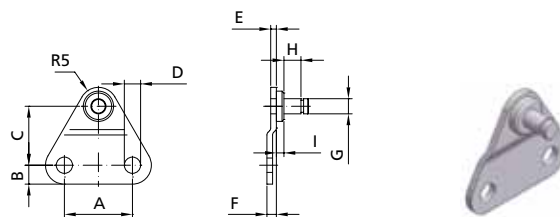

Side bracket

Type	A	B	C	D	E	F	G	H	I	Stability	Steel	AISI 316L/Ti
BB01/K08	18 mm	5 mm	15.5 mm	4.3 mm	1.5 mm	2.5 mm	8 mm	8 mm	3 mm	180 N	•	•
BB01/Z04	18 mm	5 mm	15.5 mm	4.3 mm	1.5 mm	2.5 mm	4 mm	4.5 mm	2 mm	180 N	•	•
BB01/Z06	18 mm	5 mm	15.5 mm	4.3 mm	1.5 mm	2.5 mm	6 mm	6.5 mm	4 mm	180 N	•	•
BA01/K08	55 mm	7 mm	30 mm	5.3 mm	3 mm	5 mm	8 mm	8 mm	3 mm	500 N	•	•
BA01/K10	55 mm	7 mm	30 mm	5.3 mm	3 mm	5 mm	10 mm	8 mm	3 mm	800 N	•	•
BA01/K13	55 mm	7 mm	30 mm	5.3 mm	3 mm	5 mm	13 mm	9.5 mm	3 mm	1200 N	•	•
BA01/Z06	55 mm	7 mm	30 mm	5.3 mm	3 mm	5 mm	6 mm	7 mm	4 mm	500 N	•	•
BA01/Z08	55 mm	7 mm	30 mm	5.3 mm	3 mm	5 mm	8 mm	11 mm	5 mm	1200 N	•	•



BA30/K

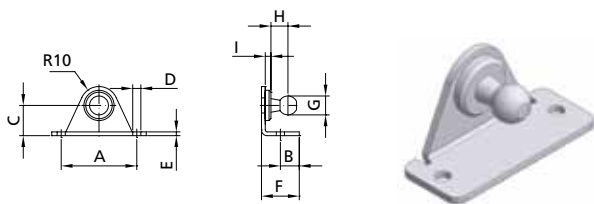

BA30/Z

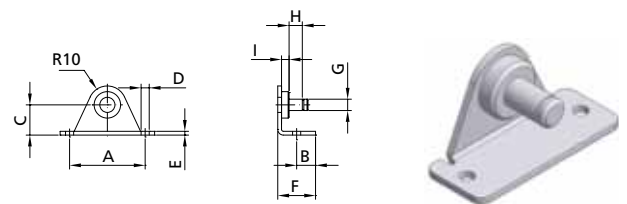

BB20/K

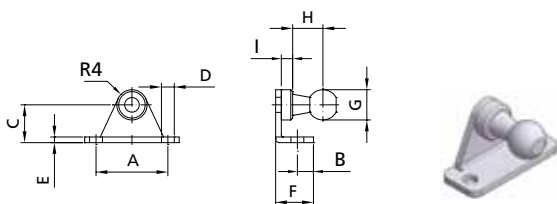

BB20/Z

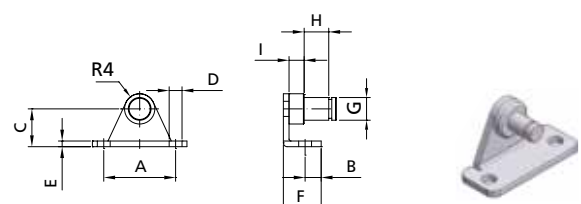

Angular bracket

Type	A	B	C	D	E	F	G	H	I	Stability	Steel	AISI 316L/Ti
BB20/K08	19 mm	4.25 mm	10 mm	3.4 mm	1.5 mm	10 mm	8 mm	8 mm	3 mm	180 N	•	•
BB20/Z04	19 mm	4.25 mm	10 mm	3.4 mm	1.5 mm	10 mm	4 mm	4,5 mm	2 mm	180 N	•	•
BB20/Z06	19 mm	4.25 mm	10 mm	3.4 mm	1.5 mm	10 mm	6 mm	7 mm	4 mm	180 N	•	•
BA30/K08	40 mm	10 mm	16 mm	5.3 mm	2 mm	20 mm	8 mm	8 mm	3 mm	500 N	•	•
BA30/K10	40 mm	10 mm	16 mm	5.3 mm	2 mm	20 mm	10 mm	9 mm	3 mm	800 N	•	•
BA30/K13	40 mm	10 mm	16 mm	5.3 mm	2 mm	20 mm	13 mm	9.5 mm	3 mm	1200 N	•	•
BA30/Z06	40 mm	10 mm	16 mm	5.3 mm	2 mm	20 mm	6 mm	7 mm	4 mm	500 N	•	•
BA30/Z08	40 mm	10 mm	16 mm	5.3 mm	2 mm	20 mm	8 mm	11 mm	5 mm	1200 N	•	•

Extras

With special protection tubes, locking devices and other extras, HAHN gas springs can also be used in difficult environments. For even more extreme conditions, our specialists and technicians develop intelligent solutions that meet virtually every requirement.

1 – Wiper ring

The wiper ring prevents foreign matter from entering into the gas springs.

2 – Radial valve

Via the radial valve, the force of the gas spring can be adjusted when it is built in. Radial valves need to be considered when calculating the length of the gas spring (GL).

3 – Piston rod sealing

Prevents humidity, cleaning agents and other foreign matters from entering into the release system of the locking gas springs

4 – Grease chamber

Permanent lubrication of the piston rod; thus lower friction forces and installation of the gas spring independent from the position. When designing the gas spring, a reduction of the usable stroke needs to be considered.

5 – Valve

The valve allows the force of the gas spring to be adjusted. In the gas spring, it is located at the threaded pin of the base plate; in the tension spring, it is designed as a valve section on the piston rod.

6 – Protection tube

Protects the piston rod from mechanical damage. Reduces the risk of bending for long strokes

7 – Floating piston

Oil-hydraulic damping along the entire stroke, independent of the installation position

8 – Locking device

Mechanical locking for extended piston rod. The locking device needs to be considered when calculating the length of the gas spring (GL).

9 – Short release

The release way for locking gas springs is 0.1 - 0.2 mm (standard 2 - 5 mm).

B3 – Sealing system

For gas springs with high forces and increased wear, e.g. use in building machines. Allows an installation of the gas spring independent of the position. When designing the gas spring, a reduction of the usable stroke needs to be considered.

NT – Low-temperature design

For use of gas springs at an ambient temperature of up to - 40°C. Allows installation of the gas spring independent of the position. When designing the gas spring, a reduction of the usable stroke needs to be considered.

HT – High-temperature design

For use of gas springs at an ambient temperature of up to 200°C. Allows installation of the gas spring independent of the position. When designing the gas spring, a reduction of the usable stroke needs to be considered.

RK – Friction element

Increases the friction force for gas springs for the secure positioning of windows, skylights, etc.

Must be observed prior to mounting, construction or storage!

1. If gas springs, tension springs or dampers are used in environments where a failure of the product can lead to damage to persons and/or material damage, additional security elements must be applied. When installing/removing gas springs or tension springs, the accident prevention measures always must be kept in mind. HAHN products may only be used in the aviation, aerospace and shipping industry with written authorisation of HAHN Gasfedern GmbH.
2. Installation + storage of the products: Gas springs must be stored with the piston rod pointing downwards, tension springs with the piston rod upwards, dampers with the piston rod downwards. Pressure losses as a result of storage according to the instructions are not to be expected; however, the products should not be stored for longer than 1 year. When using the products for the first time (compression/extension of the piston rod) after longer periods of non-use, it is possible that a sticking effect (slip-stick effect) occurs; therefore, stronger forces are required to compress or extend the piston rod. Prior to installing the products, the film tubing must be removed.
3. Gas springs, tension springs and dampers are not safety parts. Gas springs, tension springs and dampers are wear parts and thus must be replaced depending on the stress applied and the area of application. They must be particularly protected from corrosion in order to increase their life time and durability. Small amounts of hydraulic oil can escape from the products; these must not come into contact with food or ground water.
4. Filling of the products is only allowed with written authorisation of HAHN Gasfedern GmbH.
5. Do not open – high pressure! Do not heat to more than 80°C!
6. Make sure there is sufficient play in the cylinder hook-ups, i.e. avoid rigid installation. If required, lubricate cylinder hook-ups in order to achieve lower friction forces and an increased life time of the fittings.
7. Screwed-on fittings (lugs etc.) must be screwed in completely and rest firmly on the face if required. Possibly loose fittings must be screwed on completely prior to installation. Should vibrations occur, the fittings must be secured against twisting (by gluing in).
8. Make sure the piston rod does not get jammed (for long strokes/products, an additional bearing/guide must be provided for the product; sagging, bending or kinking must be avoided).
9. Only axial loads are permissible (risk of kinking!). Cross or torsion forces must not occur.
10. Gas springs must not be stressed on extension, tension springs not on compression.
11. Gas springs, tension springs as well as dampers may be used as end brackets if the nominal force +30% is not exceeded (no overstretching or jarring of the product), i.e. the products may only be loaded with their nominal force +30% on compression or tension. Mechanical brackets should particularly be applied in addition in case of strong forces in order to rule out a jarring or overstretching of the product.
12. Temperature range for use -20°C to +80°C. For use in temperatures below 0°C, we kindly ask you to specify this. In case of temperature variations, the compression or tension forces of the products also change. The viscosity of the oil also changes if temperatures vary. (Change of the damping behaviour, particularly for dampers)
13. Small damage, corrosion or paint residues on the piston rod lead to a failure of the spring (sealings are damaged). The cylinder tube must not be damaged or deformed. Generally, all changes on the product made by third parties result in an exclusion of warranty.
14. Tension springs are open systems, i.e. it must be avoided that dirt or other media get into the tension springs through the ventilation hole at the cylinder end. (Installation with the piston rod pointing upwards). During installation, it is necessary to make sure that the tension springs are not installed in closed systems but in ventilated systems, in which condensate cannot develop due to temperature variations.
15. Locking gas springs have a tube as the piston rod, which contains a release pin. It is necessary to avoid that foreign media such as dirt or cleaning agents get into the piston rod hole. This can lead to corrosion in the piston rod and cause the release pin to get wedged. Preferentially, the locking gas springs should be installed with the piston rod pointing downwards. If locking gas springs are used in environments where they get into contact with cleaning agents (hospital beds), this generally must be specified. Maximum number of release activities approx. 30,000.
16. Warranty is excluded for any installation suggestions/drawings for gas springs, tension springs and dampers. It must be considered that not all installation parameters can be included in the theoretical suggestion; therefore, the installation must be carried out with utmost care in practice, since friction values or accelerations cannot or can only roughly be considered in the theoretical suggestion.
17. The installation or use of gas springs or tension springs should generally be tested by the user under operating conditions, since the operating or installation conditions are very varied and thus not all parameters can be simulated or tested at HAHN. It is generally necessary to specify whether the products are used under normal conditions (20°C, natural environment = air) or whether foreign media (e.g. water vapour > 80°C, diverse chemicals, cleaning agents) impact on them.

Tolerances/characteristics/disposal

1. Maximum pressure = 160 bars (20°C)
2. Maximum stroke speed = 300 mm/s in installed state.
Attention: High stroke speeds or stroke frequencies lead to an overheating and thus to damage to the sealings and the failure of the product. High stroke speeds or accelerations must not lead to an overload of the product.
3. Length tolerance of the products = +/- 2 mm
4. The tolerance for compression or tension forces generally is: (exact values in our testing instructions) minimum +/- 3 Newton +/- 5% of the nominal force; maximum +/- 10% of the nominal force (20°C). The nominal force is measured statically at extending stroke (for tension springs, at compressing stroke) 5 mm before stroke end (standard). Release force for pushing in the release pin for locking gas springs: approx. 18% of the nominal force F1 of the gas spring.
5. Life time: Depending on the function, the series and the stroke of the gas spring, a life time of more than 50,000 load changes is possible. Environmental influences and the installation situation can significantly reduce the life time. You can obtain further information on the life time of the spring you have selected from our technology department.
6. Disposal: Dampers, gas springs and tension springs are under pressure. They must not be opened or heated up. The products may only be opened according to the instructions by HAHN Gasfedern GmbH (on request, you can obtain them by post). All products have an oil filling; this must be disposed of according to the Waste Management Law.

Warranty is excluded for any non-observance of the above instructions.

Sales partners

We have a close world-wide network of sales partners, who can help you solve your tasks directly on location.

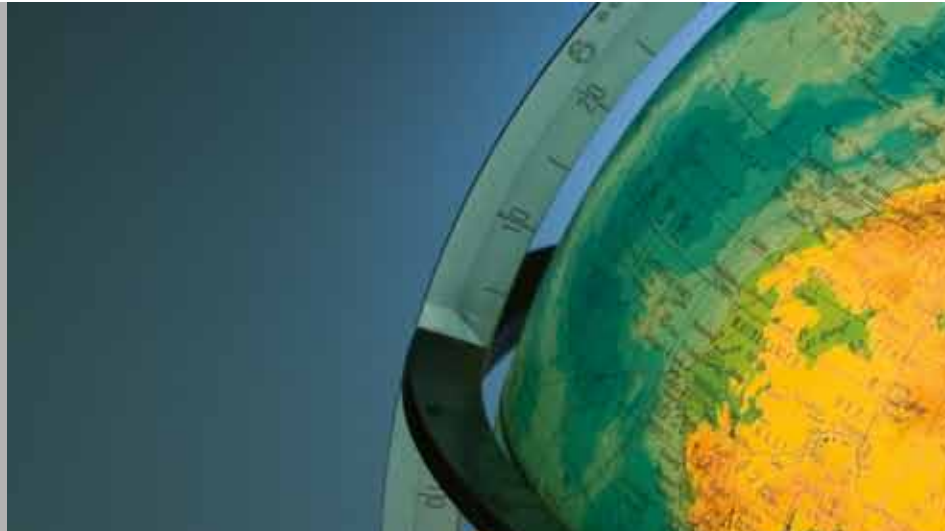

Germany

HAHN Gasfedern GmbH
Waldstraße 39-43
73773 Aichwald
Phone: +49(0)711 936 705-0
Fax: +49(0)711 936 705-40
info@hahn-gasfedern.de
www.hahn-gasfedern.de

Italy

Emanuele Mascherpa S.p.A.
Via Natale Battaglia, 39
20127 Milano
Phone: +3902-280031
Fax: +3902-2829945
postmaster@mascherpa.it
www.mascherpa.it
Contact: Mr. Marco Scoglio

Austria

Rothmund und Konhäuser KG
Laxenburgerstrasse 240-242
1239 Wien
Phone: +43 1616 2611
Fax: +43 1616 0343
office.industrie@roko.at
www.roko.at
Contact: Mr. Friedrich Zöllner

Switzerland

Eckold AG
Rheinstrasse
7203 Trimmis
Phone: +41 8135 4125 4
Fax: +41 8135 4125 1
verkauf@eckold.ch
www.eckold.ch

Denmark

RGE Europe ApS
Maglebjergvej 4
2800 Kgs. Lyngby
Phone: +45 3966 3030
mab@rge-europe.com
www.rge-europe.com
Contact: Mrs. Maj-Britt Brocelius

Finland

MOVETEC OY
Hannuksentie 1
02270 Espoo
Phone: +358 9525 9230
Fax: +358 9525 9233 3
pekka.jokinen@movetec.fi
www.movetec.fi
Contact: Mr. Pekka Jokinen

France

ECKO TECH
16, rue de la Noue Guimante
Z.I. de la Courtillière
77400 Saint Thibault des Vignes
Phone: +33 1643 0924 7
Fax: +33 1643 0819 2
info@eckold.fr
www.eckold.fr
Contact: Mr. Frédéric Delacourt

Great Britain/Ireland

ECKOLD Ltd.
15 Lifford Way
Binley Industrial Estate
West Midlands CV32RN, Coventry
Phone: +44 2476 455580
Fax: +44 2476 456931
sales@eckold.co.uk
www.eckold.co.uk
Contact: Mr. Mark Watton

Netherlands/Belgium/Luxemburg

Protempo B.V.
Postfach 21
6500 AA Nijmegen
Phone: +31 0243 7117 11
Fax: +31 0243 7117 00
info@protempo.nl
www.protempo.nl
Contact: Mr. A.C.M. Jansen

Norway

A.C. LANDGRAFF AS
Postboks 14
Nesveien 13
1305 Haslum
Phone: +47 6752 6000
Fax: +47 6753 8812
landgraff@landgraff.no
www.landgraff.no
Contact: Mr. Morten Landgraff

Sweden

Aratron AB
Smidesvägen 4-8
S-17141 Solna
Tel.: +46 8404 1600
Fax: +46 8984 281
info@aratron.se
www.aratron.se
Contact: Mr. Niklas Granström

Spain/Portugal

DICTATOR ESPAÑOLA, S.A.
C/ Mogoda, 20-24 P.I. Can Salvatella
08210-Barbera del Valles
Phone: +34 9371 9131 4
Fax: +34 9371 8250 9
dictator@dictatorspain.com
Contact: Mr. Xavier Diago



Czech Republic/Slovakia

ECKOLD&VAVROUCH spol. s r.o.
 Jilemnickeho 8
 614 00 Brno
 Phone: + 420 5452 1158 2
 Fax: + 420 5452 1158 2
 eckold@volny.cz
 www.eckold.cz
 Contact: Mr. Martin Vavrouch

USA

Allegis Corporation
 8001 Central Ave. NE.
 Minneapolis, MN 55432
 Phone: +1 866 378 7550
 salesmidwest@allegiscorp.com
 www.allegiscorp.com

China

SERVO DYNAMICS Co. Ltd.
 4th Floor, Block No.1,
 ISND Holding Ind. Park
 Wujiang Economic Development Zone
 1128 East Jiangxing Road
 215200 Suzhou
 Phone: +86 512 82079788
 Fax: +86 512 82079063
 info@servodynamics.com.cn
 www.servodynamics.com.cn
 Contact: Mrs. Lily Chen

India

A.C. AUTOMATION
 B-134, Street # 1,
 Majlis Park (Near Azadpur),
 110033 Delhi
 Phone: +91 1127 6748 39
 Fax: +91 1127 6813 49
 ac@ac-automation.com
 www.ac-automation.com
 Contact: Mr. Anoop Chopra

Israel

SystematiTech Ltd.
 Paz Hateomim center, Mishmar Hashiva
 P.o. box 21125
 61211 Tel-Aviv
 Phone: +972 0396 0500 8
 Fax: +972 0396 0500 4
 sales@systematitech.com
 www.systematitech.com
 Contact: Mr. Natan Rom

Pakistan

CAPRICORN TRADING
 G-6, Ground Floor
 Entrance „A“
 10 Mules Mansions
 Napier Mole Road
 Keamari
 Karachi - 75620
 Phone: + 92 21 32862855 & 32862866
 Mobile: + 92 334 3659001
 capricorntrading@gmail.com
 Contact: Mr. Zubin F. Mavalvala
 (Proprietor)

Southeast Asia

SERVO DYNAMICS Pte Ltd.
 No. 10 Kaki Bukit Road 1
 #01-30 KB Industrial Building
 SINGAPORE 416175
 Phone: +65 6844 0288 Ext. 72
 Fax: +65 6844 0070
 servodynamics@servo.com.sg
 www.servo.com.sg
 Contact: Mr. S.Y. Low

Japan

ECKOLD Japan Co., Ltd.
 ZIP: 274-0824
 2-14-2, Maehara-Higashi,
 Funabashi, Chiba-Pref.
 Phone: +81 47 470 2400
 Fax: +81 47 470 2402
 tokita@eckold.co.jp
 www.eckold.co.jp
 Contact: Mr. Tomoyuki Tokita

Poland

EA Kraków s.c.
 32-050 Skawina
 ul. Piłsudskiego 39 b
 Phone: +48 12 276 07 70
 Fax: +48 12 276 37 74
 kf@ea.krakow.pl
 www.ea.krakow.pl
 Contact: Mr. Krzysztof Frączek

Hungary

Eurowind Kft.
 Alba Industrial Zone
 Zsálya street, nr. 5
 8000 Székefehérvár
 Phone: + 36 22 505 725
 Fax: + 36 22 331 666
 eurowind@eurowindgroup.com
 www.eurowindgroup.com
 Contact: Mr. Róbert Nagy

Romania

S.C. PARCON S.R.L.
 Str. Depozitelor nr. 22
 540240 Tg Mures
 Phone: +40 265 253 088
 Mobile: +40 730 960 527
 husar@parconfreiwald.ro
 Contact: Mr. Paul Husar

HAHN Gasfedern GmbH
Waldstrasse 39-43
73773 Aichwald
GERMANY

Phone: +49(0)711 936 705 - 50
Fax: +49(0)711 936 705 - 40

info@hahn-gasfedern.de
www.hahn-gasfedern.de